



# ULTIMHEAT

---

## HEAT & CONTROLS



# THERMOSTATS WITH INGRESS PROTECTION HOUSINGS

- For thermostats without housing:
- Explosion proof versions:

See catalogue No.1

See catalogue No.4

Contact us









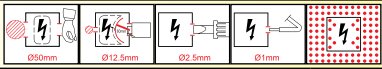

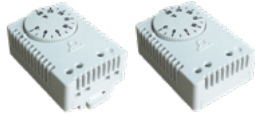

Because of permanent improvement of our products, drawings, descriptions, features used on these data sheets are for guidance only and can be modified without prior advice

Section 1	Summary	P1-P8
Section 2	 Technical introduction	P1-P12
Section 3	Alphabetical and reference tables	P1-9



## Mechanical thermostats for room temperature control

**P1-P12**

Section 4	<b>IP30</b>	<b>PC-ABS</b>	Y02N, Y02M	Miniature ambient temperature thermostat for electrical cabinets.	P3-P4
					
	<b>IP65</b>	<b>PC-ABS</b>	Y22	Fixed setting room or antifreeze thermostat, with one or 2 pilot lights.	P5-P6
					
	<b>IP44</b>	<b>PC-ABS</b>	Y035, Y036	Ambient temperature thermostat, pig tail sensor. Miniature plastic enclosure IP44, with internal adjustment. One M20 cable gland for round or oblong cables. Also available with outside adjustment knob.	P7
					
	<b>IP55</b>	<b>PC-ABS</b>	Y0D8, Y0D9	Ambient temperature thermostat, IP55 plastic enclosure, for heat tracing, pig tail sensor. Internal adjustment, one pilot light, and additional internal connection block. 1, 2 or 3 M20 cable glands for round or oblong cables. Also available with outside adjustment knob.	P8
					
	<b>IP55</b>	<b>PC-ABS</b>	Y2B, Y2K	Ambient temperature thermostat IP55 plastic enclosure, pig tail bulb, two pilot lights, reduced width, external adjustment or internal adjustment under transparent cover.	P9
					
<b>IP65</b>	<b>Aluminium</b>	Y1B8G, Y1A8G	Ambient measurement thermostat, pig tail bulb, inside IP65, IK10 aluminum enclosure, one pilot light, two M20 cable glands for round or oblong cables. Adjustment under window. Also available with internal adjustment knob, full aluminum enclosure.	P10	
					
<b>IP66</b>	<b>PA66 + PC</b>	YF7GNC	Ambient temperature control thermostat, pig tail bulb, IP66, IK10, PA66 housing with polycarbonate transparent cover.	P11	
					







## Bulb and capillary mechanical thermostats

**P1-P20**

Section 5	<b>IP44</b>	<b>PC-ABS</b>	Y039, Y038	Bulb and capillary thermostat. Miniature plastic enclosure IP44, with internal adjustment. One M20 cable gland for round or oblong cables. Also available with outside adjustment knob.	P3-P4
					
	<b>IP55</b>	<b>PC-ABS</b>	Y0A9, Y0A8	Bulb and capillary thermostat, IP55 plastic enclosure with internal adjustment, and additional internal connection block. One pilot light, 1, 2 or 3 M20 cable glands for round or oblong cables. Also available with outside adjustment knob.	P5-P6
					



## Summary



Section 5	IP44	PC-ABS	Y08		Thermostat and manual reset limiter combination, with IP44 plastic enclosure, 105 × 88 × 58.5mm, with pilot light, capillary output for distant sensing	P7-P8
	IP44	PC-ABS				
	IP44	PC-ABS	Y09		Thermostat and manual reset limiter combination, with IP44 plastic enclosure, 105 × 88 × 58.5mm, with pilot light, special bracket for direct mounting on 1"1/2 or M45 immersion heaters	P9-P10
	IP55	PC-ABS				
	IP55	PC-ABS	Y2D, Y2M		Bulb and capillary thermostat, IP55 plastic enclosure, two pilot lights, reduced width, external adjustment or internal adjustment under transparent cover	P11-P12
	IP65	Aluminium				
	IP65	Aluminium	Y18G, Y1G8G		Bulb and capillary thermostat, IP65, IK10, aluminum enclosure, one pilot light, two M20 cable glands for round or oblong cables. Adjustment under transparent window. Also available with internal adjustment knob, full aluminum enclosure	P13-P14
	IP65	Aluminium				
IP65	Aluminium	Y18C, Y1G8C		3 poles bulb and capillary thermostat, IP65, IK10, aluminum enclosure, two M20 cable glands for round or oblong cables. Adjustment under transparent window. Also available with internal adjustment knob, full aluminum enclosure	P15-P16	
IP66	PA66 + PC					
IP66	PA66 + PC	YF8GNC		Adjustable set point bulb and capillary thermostat, IP66, IK10, PA66 housing with polycarbonate transparent cover, with extension for direct mounting on 1"1/2 immersion heater	P17-P18	
IP66	PA66 + PC					
IP66	PA66 + PC	YF9GNC		Bulb and capillary thermostat, IP66, IK10, PA66 housing with polycarbonate transparent cover	P19-P20	

### Rod mechanical thermostat













**P1-P22**

Section 6	IP44	PC-ABS	Y049, Y048		Rod thermostat. Miniature plastic enclosure IP44, with internal adjustment. One M20 cable gland for round or oblong cables. With metal pocket or plastic pocket. Also available with outside adjustment knob	P3-P4
	IP44	PC-ABS				
	IP44	PC-ABS	Y0B8, Y0B9		Rod thermostat, IP55 plastic enclosure, with internal adjustment, and additional internal connection block. One pilot light, 1, 2 or 3 M20 cable glands for round or oblong cables. Also available with outside adjustment knob	P5-P6
IP44	PC-ABS					
IP44	PC-ABS	Y0B		Thermostat with IP44 extra flat plastic enclosure, 95 × 60 × 40mm, with pilot light. Rod temperature sensor. Stainless steel or Brass pocket. 1, 2 or 3 cable glands	P7-P8	

Because of permanent improvement of our products, drawings, descriptions, features used on these data sheets are for guidance only and can be modified without prior advice











Because of permanent improvement of our products, drawings, descriptions, features used on these data sheets are for guidance only and can be modified without prior advice

Section 6	IP55	PC-ABS	Y06, Y07		Thermostat and manual reset limiter combination, with IP44 plastic enclosure, 105 × 88 × 58.5mm, with pilot light, rod temperature sensing	P9-P10
						
	IP65	Aluminium	Y1S8G, Y1R8G		Rod thermostat, IP65, IK10, aluminum enclosure, one pilot light, two M20 cable glands for round or oblong cables. Adjustment under transparent window. Also available with internal adjustment knob, full aluminum enclosure	P11-P13
						
	IP65	Aluminium	Y1U		Rod thermostat, control, inside adjustment, miniature housing, (single pole and double pole)	P14-P15
						
	IP65	Aluminium	Y1S8C, Y1R8C		3 poles rod thermostat, IP65, IK10, aluminum enclosure, two M20 cable glands for round or oblong cables. Adjustment under transparent window. Also available with internal adjustment knob, full aluminum enclosure	P16-P18
						
IP66	PA66 + PC	YF4GNC		Rod thermostat, IP66, IK10, PA66 housing with polycarbonate transparent cover	P19-P20	
						
IP66	 PP or PVDF	YF5GPP		Adjustable set point rod thermostat, with high corrosion resistance IP66 enclosure in Polypropylene, specifically designed for surface treatment baths, and highly basic or acid corrosive liquids or environments. Also available with PVDF enclosure	P21-P22	
						

### Pipe mounting mechanical thermostats

**P1-P12**

Section 7	IP55	PC-ABS	Y2H, Y2P		Pipe mounting thermostat, IP55 plastic enclosure, two pilot lights, reduced width, external adjustment and internal adjustment under transparent cover	P3
						
	IP65	Aluminium	Y118G, Y108G		Pipe mounting thermostat, IP65, IK10, aluminum enclosure, one pilot light, two M20 cable glands for round or oblong cables. Adjustment under transparent window. Also available with internal adjustment knob, full aluminum enclosure	P4-P5
						
	IP65	Aluminium	Y118C, Y108C		3 poles pipe mounting thermostat, IP65, IK10, aluminum enclosure, one pilot light, two M20 cable glands for round or oblong cables. Adjustment under transparent window. Also available with internal adjustment knob, full aluminum enclosure	P6-P7
						
IP65	Aluminium	Y1G8L, Y1I8L		Bulb and capillary manual reset high limit thermostat, fail safe, IP65, IK10, aluminum enclosure, two M20 cable glands for round or oblong cables. Nonadjustable manual reset under transparent window with pilot light. Also available with internal reset button under aluminum cover (Without window).	P8-P9	
						

# Summary



Section 7	IP65	PA66 + PC	YF9LNC	Manual reset bulb and capillary thermostat, fail safe, non-adjustable set point, IP66, IK10, PA66 housing with polycarbonate transparent cover	P10
Section 7	IP66	PA66 + PC	YF8LNC	High limit manual reset thermostat, fail safe, for direct mounting on immersion heaters, non-adjustable set point, with PA66 body and transparent cover, for low corrosive liquids	P11-P12

## Mechanical thermostats for surfaces measurement

**P1-P4**

Section 8	IP65	PA66	Y2U	Thermostat for temperature control of flexible or rigid surfaces	P3
Section 8	IP65	PA66	Y2W	Thermostat with internal adjustment, IP65, with two pilot lights, for surface mounting on industrial jacket heaters, blanket heaters and silicone heaters	P4

## Mechanical temperature limiters, with rod or pipe mounting

**P1-P10**

Section 9	IP65	Aluminium	Y1S8L, Y1R8L	Rod type manual reset high limit thermostat, fail safe, IP65, IK10, aluminum enclosure, two M20 cable glands for round or oblong cables. Internal nonadjustable manual reset with reset under transparent window Also available with internal reset button under aluminum cover (Without window)	P3-P4
			Y1Y	Miniature enclosure rod temperature limiter, internal adjustment, external manual reset (single pole and double pole)	P5-P6
	IP65	Aluminium	Y118L, Y108L	Pipe mounting type manual reset high limit thermostat, fail safe, IP65, IK10, aluminum enclosure, two M20 cable glands for round or oblong cables. Internal non-adjustable manual reset with reset under transparent window Also available with internal reset button under aluminum cover (Without window).	P7
		YF4LNC	High limit manual reset rod thermostat, fail safe, non-adjustable set point, with PA66 body and transparent cover, using standard 1/2" fitting stainless steel, for low-corrosive liquids	P8-P9	

## Electronic room thermostats

**P1-P6**







Section 10	IP65	Aluminium	Y1A2P, Y1B2P	Low differential electronic room thermostat, NTC sensor, IP65, IK10, aluminum enclosure, one pilot light, two M20 cable glands for round or oblong cables. Adjustment under window. Also available with internal adjustment knob, full aluminum enclosure	P3-P4
		YF62NC	Ambient temperature control electronic thermostat, low differential, IP66, IK10, PA66 housing with polycarbonate transparent cover	P5-P6	

Because of permanent improvement of our products, drawings, descriptions, features used on these data sheets are for guidance only and can be modified without prior advice











Because of permanent improvement of our products, drawings, descriptions, features used on these data sheets are for guidance only and can be modified without prior advice

Remote sensor electronic thermostats					P1-P10
Section 11	IP65	Aluminium	 Y1I2P, Y1G2P	Low differential electronic thermostat, distant NTC sensor, IP65, IK10, aluminum enclosure, one pilot light, two M20 cable glands for round or oblong cables. Adjustment under crystal clear window. Also available with internal adjustment knob, full aluminum enclosure	P3-P4
	IP66	PA66 +PC			
	 YF92NC, YF94NC		YF82NC	Adjustable set point electronic thermostat with low differential, IP66, IK10, PA66 housing with polycarbonate transparent cover, with extension for direct mounting on 1"1/2 immersion heater	P5-P6
	IP66	PA66 +PC			
	 2DPAP6F		YF52PP	Low differential electronic rod thermostat, with high corrosion resistance IP66 enclosure in Polypropylene, specifically designed for surface treatment baths, and highly basic or acid corrosive liquids or environments. Also available with adjustable range and manual reset. Also available with PVDF enclosure	P7-P8
IP66	PA66 +PC				
<b>Electronic thermostats, with rod sensor or pipe mounting</b>					<b>P1-P12</b>
Section 12	IP65	Aluminium	 Y1S2P, Y1R2P	Low differential electronic thermostat, probe sensor, IP65, IK10, aluminum enclosure, one pilot light, two M20 cable glands for round or oblong cables. Adjustment under transparent window. Also available with internal adjustment knob, full aluminum enclosure	P3-P4
	IP65	Aluminium			
	 Y112P, Y102P		YF42NC, YF44NC	Low differential electronic rod thermostat, with PA66 body and crystal clear cover, using standard 1/2" fitting stainless steel pockets. For low-corrosive liquids	P5-P6
	IP66	PA66 +PC			
	 YF52PP		Y2T2 & Y2T3	Electronic room thermostat, wall mounting, knob adjustment under window. On-off action with adjustable differential. Inside IP69K housing. One M20 cable gland. Available with built-in or remote temperature sensor.	P9-P10
	IP66	PA66 +PC			
 Y2T2 & Y2T3				P11-P12	



Manual reset electronic thermostat, for room temperature control					P1-P6
Section 13	IP65	Aluminium	 Y1B2L, Y1A2L	Ambient high limit manual reset thermostat, IP65, IK10, aluminum enclosure, two M20 cable glands for round or oblong cables. Adjustable set point and manual reset under transparent window. Also available with internal adjustment and reset button under aluminum cover (Without window)	P3-P4
	IP66	PA66 + PC			

Manual reset electronic thermostat, with remote sensor, for temperature control					P1-P8			
Section 14	IP65	Aluminium	 Y1I2L, Y1G2L	Adjustable manual reset electronic limiter, distant NTC sensor, IP65, IK10, aluminum enclosure, one pilot light, two M20 cable glands for round or oblong cables. Adjustment under transparent window. Also available with internal adjustment knob, full aluminum enclosure	P3-P4			
	IP66	PA66 + PC				 YF93NC, YF95NC	Distant sensor manual reset adjustable electronic limiter, IP66, IK10, PA66 housing with polycarbonate transparent cover	P5-P6
	IP66	PA66 + PC				 YF83NC	Adjustable set point electronic limiter, IP66, IK10, PA66 housing with polycarbonate crystal clear cover, with extension for direct mounting on 1"1/2 immersion heater	P7P-8



Manual reset electronic thermostat, rod or pipe mounting sensor, for temperature control					P1-P12			
Section 15	IP65	Aluminium	 Y1S2L, Y1R2L	Adjustable set point electronic limiter, probe sensor, IP65, IK10, aluminum enclosure, one pilot light, two M20 cable glands for round or oblong cables. Adjustment under transparent window. Also available with internal adjustment knob, full aluminum enclosure (IP65)	P3-P5			
	IP65	Aluminium				 Y1I2L, Y1O2L	Adjustable electronic limiter, pipe mounting. Adjustment under window. Also available with adjustment under aluminum cover (Without window)	P6-P7
	IP66	PA66 + PC				 YF43NC, YF45NC	Probe sensor manual reset adjustable electronic limiter, IP66, IK10, PA66 housing with polycarbonate transparent cover	P8-P9

Because of permanent improvement of our products, drawings, descriptions, features used on these data sheets are for guidance only and can be modified without prior advice

# Summary





Because of permanent improvement of our products, drawings, descriptions, features used on these data sheets are for guidance only and can be modified without prior advice

Section 15	IP66		PP or PVDF	YF53	Electronic limiter, probe sensor, adjustable manual reset, with high corrosion resistance IP66 enclosure in Polypropylene, specifically designed for surface treatment baths, and highly basic or acid corrosive liquids or environments. Also available with PVDF enclosure	P10-P12
						

## Accessoires

**P1-P18**

Section 16			9BF	Flexible silicone enclosures for flexible heating pad thermostats and sensors	P3-P9
			66D, 66R, 66B, 66T, 9BB	Pockets, flanges and accessories for thermostats with housings	P10-P18



Because of permanent improvement of our products, drawings, descriptions, features used on these data sheets are for guidance only and can be modified without prior advice





# Section 2

## Technical introduction

Because of permanent improvement of our products, drawings, descriptions, features used on these data sheets are for guidance only and can be modified without prior advice



Because of permanent improvement of our products, drawings, descriptions, features used on these data sheets are for guidance only and can be modified without prior advice



Because of permanent improvement of our products, drawings, descriptions, features used on these data sheets are for guidance only and can be modified without prior advice

The housings are designed to protect electrical equipment located inside. This protection must be considered in the electrical and environmental angles.

Sets Y0 to Y5 describe products with protection classes which are different and intended for different applications. This introduction allows to understand and define the specifications for an application.

For further information on the specific protection explosive atmospheres, see catalogs No. 4 and No. 2 for the resistance of plastics and elastomers to temperature and UV

## Electrical protection classes

There are two main types of electrical protection, protection against the risk of **direct contact** (functional isolation) and protection against **indirect contact** hazards.

The functional isolation is not sufficient in case of electrical failure and it is necessary to add protection against the risks of indirect contacts, which can be achieved by the following means:

- The earthing of all metal parts
- Double or reinforced insulation
- A low voltage supply via a transformer

The combination of these protections determines the class of electrical protection of the device.

## The 4 electrical safety levels of electrical devices

Class	Symbol	Description
0		Equipment with only functional insulation but not binding to the metal masses. <b>Banned in Europe.</b>
1		Material with a functional isolation and earthing of metal masses. <b>These devices must be connected to earth</b>
2		Equipment with dual insulation of live parts (functional isolation and physical). No earthing of metal parts. This ensures that no double insulation accessible part may be subject to dangerous voltages even after a first insulation fault. The advantage of this class of appliances is a higher protection to the user regardless of the electrical sockets used (With or without earth terminal). <b>These devices must not be connected to earth</b>
3		Equipment class 2 transformer with a SELV (Safety Extra Low Voltage). This solution ensures that no accessible part may be subject to dangerous voltages even after a first and a second insulation fault. The electrical insulation of a device by a transformer located apart eliminates the risks of electrical ground return on a user by accidental contact with an electric leakage. On the other hand, the low voltage SELV severely limits the current that can pass through the human body in contact with two elements of the device under different potentials. The advantage of this class of appliances is a higher protection to the user regardless of the electrical sockets used (With or without earth terminal). <b>These devices must not be connected to earth</b>

## IP protection (Ingress protection)

The IP rating defined by the IEC 60529 specifies the degree of protection against ingress of solid bodies (first digit) and against the ingress of water (second digit). The third and fourth characters are optional and provide information on the level of protection.

The classification is done by increasing efficiency. There are 7 levels against solid (0: no protection, 6 fully protected) and 9 levels against water (0: no protection, 8: protected against immersion under pressure).

For example, "IP21" means protected against solid objects greater than 12.5 mm (eg a finger) and resistant to condensation.

### « X » use in the IP Coding

The letter X is used anywhere in the code when the protection it represents is meant to be avoided. There may be various reasons for choosing this coding variant, such as marketing considerations. Thus, e.g. an IPX7 rating for a consumer device specifies that the device has water protection up to limited immersion, but gives deliberately no information as to whether the device has any protection against mechanical ingress or dust. Among other common IP ratings using the letter X, is IPX4. IP2X is frequently used on electrical items to specify the item must prevent from finger access to live terminals i.e plug sockets are IP2X.

## First digit (Solid particle protection)

The first digit indicates the level of protection that the enclosure provides against access to hazardous parts (e.g., electrical conductors, moving parts) and the ingress of solid foreign objects



The first digit of the IP marking is not required by EN 60335-1

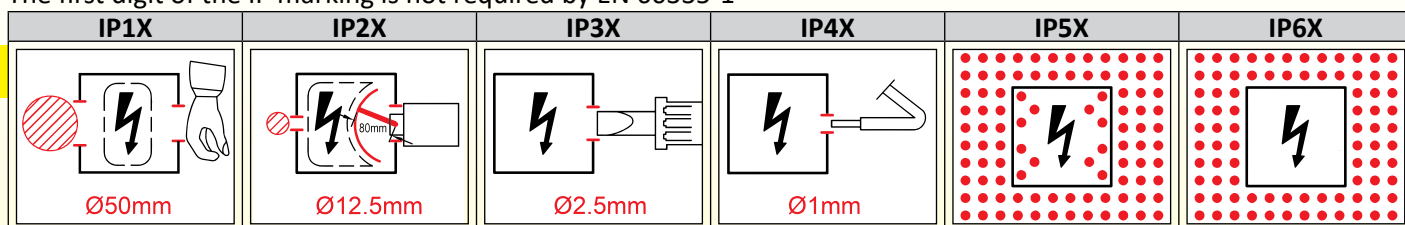

First digit	Protection type	Effective
0	No protection	No protection against contact and ingress of objects
1	Protected against solid particles >50 mm	Protected against any large surface of the body, such as the back of a hand, but no protection against deliberate contact with a smaller body part
2	Protected against solid particles >12.5 mm	Protected against fingers or similar objects
3	Protected against solid particles >2.5 mm	Protected against tools, thick wires, etc.
4	Protected against solid particles >1 mm	Protected against most wires, screws, etc.
5	Dust protected	Ingress of dust is not entirely prevented, but it must not enter in sufficient quantity to interfere with the satisfactory operation of the equipment. Completely protected against contact.
6	Dust tight	Completely protected against ingress of dust. Completely protected against contact.

## Second digit (Liquid ingress protection)

The second digit indicates the level of protection that the enclosure provides against harmful ingress of water.

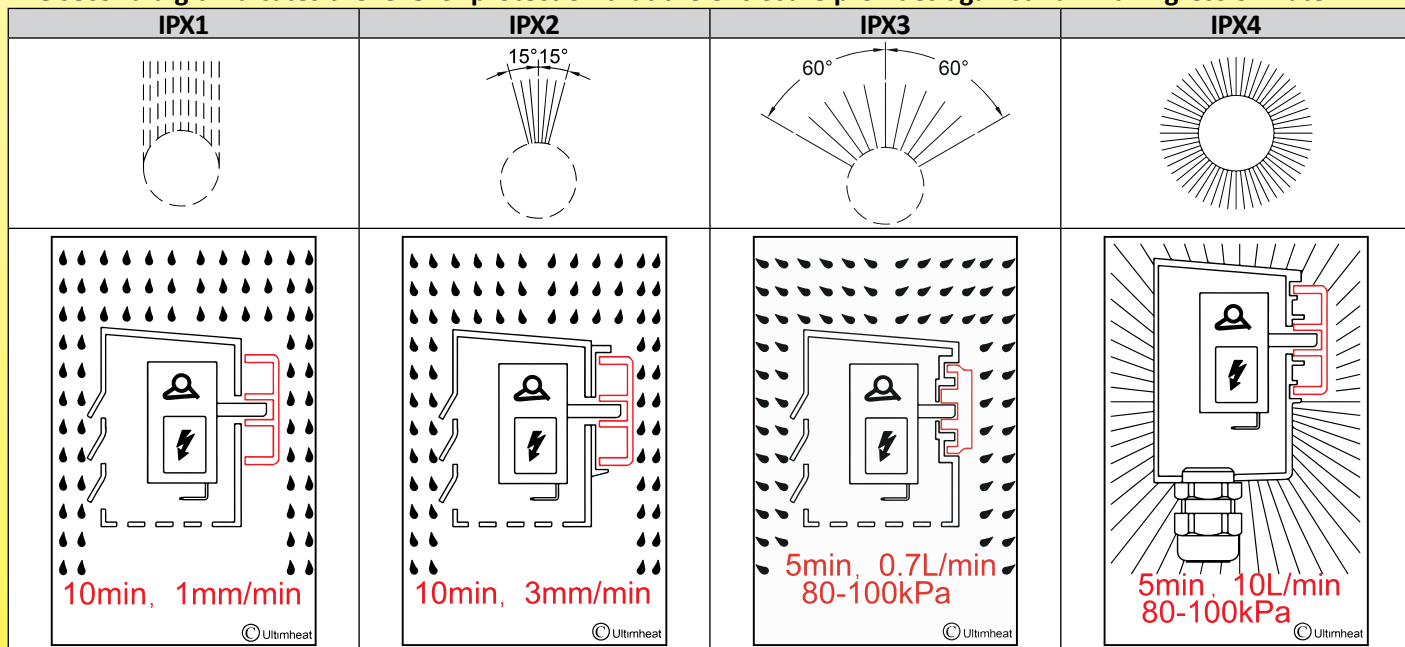

Second digit	Protection type	Effective protection	Test description
0	Not protected		
1	Dripping water	Dripping water (vertically falling drops) shall have no harmful effect.	- Water equivalent to 1 mm rainfall per minute. - Test duration: 10 minutes
2	Dripping water when tilted up to 15°	Vertically dripping water shall have no harmful effect when the enclosure is tilted at an angle up to 15° from its normal position.	- Water equivalent to 3 mm rainfall per minute. - Test duration: 10 minutes
3	Spraying water	Water falling as a spray at any angle up to 60° from the vertical shall have no harmful effect.	- Water volume: 0.7 liters per minute - Pressure: 80-100 kPa - Test duration: 5 minutes

Because of permanent improvement of our products, drawings, descriptions, features used on these data sheets are for guidance only and can be modified without prior advice



Because of permanent improvement of our products, drawings, descriptions, features used on these data sheets are for guidance only and can be modified without prior advice

Second digit	Protection type	Effective protection	Test description
4	Splashing water	Water splashing against the enclosure from any direction shall have no harmful effect.	<ul style="list-style-type: none"> <li>- Water volume: 10 liters per minute</li> <li>- Pressure: 80-100 kPa</li> <li>- Test duration: 5 minutes</li> </ul>

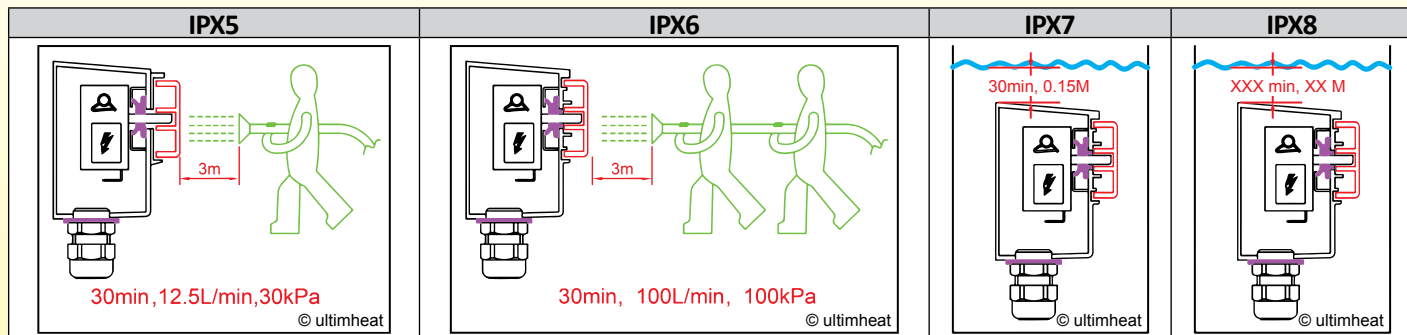

Second digit	Protection type	Effective protection	Test description
5	Water jets	Water projected by a 6.3 mm dia. nozzle against enclosure from any direction shall have no harmful effects.	<ul style="list-style-type: none"> <li>- Water volume: 12.5 liters per minute</li> <li>- Pressure: 30 kPa</li> <li>- Distance: 3 m</li> <li>- Test duration: 3 minutes</li> </ul>
6	Powerful water jets	Water projected in powerful jets (12.5 mm nozzle) against the enclosure from any direction shall have no harmful effects.	<ul style="list-style-type: none"> <li>- Water volume: 100 liters per minute</li> <li>- Pressure: 100 kPa</li> <li>- Distance: 3 m</li> <li>- Test duration: 3 minutes</li> </ul>
7	Immersion up to 1 m	Ingress of water in harmful quantity shall not be possible when the enclosure is immersed in water under defined conditions of pressure and time (up to 1 m of submersion).	<ul style="list-style-type: none"> <li>- Immersion to a depth of at least 1 m measured at bottom of device, and at least 15 cm measured at top of device</li> <li>- Test duration: 30 minutes</li> </ul>
8	Immersion beyond 1 m	The equipment is suitable for continuous immersion in water under conditions which shall be specified by the manufacturer. Normally, this will mean that the equipment is hermetically sealed. However, with certain types of equipment, it can mean that water can enter but only in such a way that it produces no harmful effects.	<ul style="list-style-type: none"> <li>- Test duration: continuous immersion in water.</li> <li>- Depth is specified by the manufacturer</li> </ul>

### First additional letter

Additional letters that can be appended to classify only the level of protection against access to hazardous parts by persons.

Letter	Protected against access to hazardous parts with
A	Back of hand
B	Fingers
C	Tools
D	Wires

### Second additional letter

Further letters can be appended to provide additional information related to the protection of the device.

Letter	Meaning
H	High voltage device
M	Device moving during water test
S	Device standing still during water test
W	Weather conditions



## IP69K (DIN 40050-9)

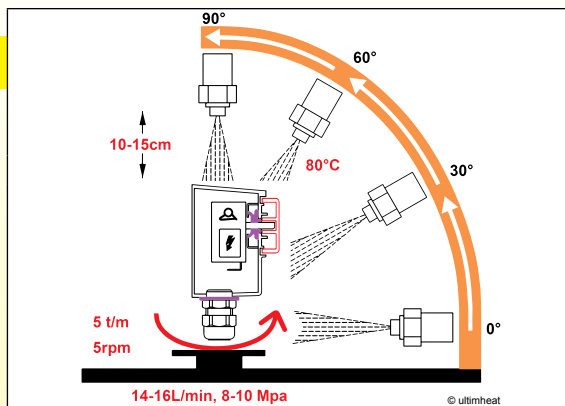

### Description

Specific ingress protection rating for high-pressure, high-temperature washing applications. Such enclosures must not only be dust tight (IP6X), but also able to withstand high-pressure and steam cleaning.

### Test description

- Water volume: 14-16L liters per minute
- Water temperature: 80°C
- Pressure: 8–10 Mpa (80–100 bar)
- Distance: 10 to 15cm from the tested device at angles of 0°, 30°, 60° and 90° for 30s each. The test device sits on a turntable that rotates once every 12s

## Examples of ingress protection ratings requested by standards and applications

An IP protection rating may be required by specific standards such as NF15100 (domestic electrical installation rules), EN60335-xx (design rules for electrical appliances) and machine-specific standards. Hereafter are the main specifications extracted from these standards.

<b>Bath rooms, swimming pools and assimilated</b>	These rooms are divided in 4 area volumes: 0,1,2,3. These volumes and installation rules are described in the French standard NFC15100, International standard Cenelec HD384 and European standard IEC 60364.
---	---

Areas	Minimal IP requirements	Electrical protection
0	All electric heaters are prohibited. Other equipments: <u>Bathrooms:</u> IPX7 <u>Pools and similar:</u> IPX8	SELV limited to 12V DC or 30V AC
1	All electric heaters are prohibited. Other equipments: <u>Bathrooms:</u> IPX4, but IPX5 if this volume can be subjected to water jets for cleaning in public baths. <u>Pools and similar:</u> IPX5	SELV limited to 12V DC or 30V AC
2	<u>Bathrooms:</u> IP24 mini heaters are authorized Other equipments: IPX3, but IPX5 if this volume can be subjected to water jets for cleaning in public baths. <u>Indoors Pools:</u> IP24 mini heaters authorized Other equipments: IPX2, but IPX5 if this volume can be subjected to water jets for cleaning. <u>Outdoors Pools:</u> IPX5	- Class 2 devices - Controls should not be accessible from the shower or bath. - Heaters must not be powered by a wall mounted socket. - Line must be protected by a 30 mA residual current circuit breaker
3	<u>Bathrooms:</u> IP21 mini heaters are authorized Other equipments: IPX1 <u>Pools:</u> Heaters authorized IP21 mini Other equipments: IPX1, but IPX5 if this volume can be subjected to water jets for cleaning. <u>Outdoors Pools:</u> IPX5	- Class 1 or Class 2 devices - Heaters must not be powered by a wall mounted socket. - Line must be protected by a 30 mA residual current circuit breaker

<b>Saunas</b>	Electrical equipment must have an IP 24 minimum protection rating
<b>Under floor heating</b>	The heating elements intended to be embedded in a concrete or other similar material must be IPX7
<b>Electrical devices that are permanently outdoor</b>	The degree of protection shall be at least IPX4.
<b>Residential, Offices, Schools</b>	Generally clean, dry and free from harmful deposits of dust, but some condensate may be present due to atmospheric conditions. Minimum protection is typically IP2X for dry conditions.
<b>Control rooms/ Sub-Stations</b>	Generally dry and free from harmful deposits of dust, but some condensate may be present due to atmospheric conditions. Where access is restricted to skilled or instructed persons, IP2X is the typical minimum requirement for dry conditions.
<b>Commercial, Light Industrial</b>	These premises may not be clean, but normally dry and free from harmful deposits of dust. Suitable minimum protection: - Where condensate is not present: IP2X - Where condensate may be present: IP21. - Equipment installed within range of fire sprinkler systems: IP22.



Because of permanent improvement of our products, drawings, descriptions, features used on these data sheets are for guidance only and can be modified without prior advice

<b>Machine control equipment</b>	Where fluids may be present, e.g. lathes, millers etc., minimum protection typically requested is IP54. Consideration should also be given to the corrosive properties of certain fluids
<b>Heavy Industrial, Chemical.</b>	These environments are not usually totally clean, with possible presence of corrosive elements and harmful deposits of dust. Protection to IP54 will be typically required, with special consideration given to the corrosion resisting properties of the enclosure. When explosion risks exist, enclosures and equipment should meet the specifications of these environments.
<b>Food Processing</b>	Will vary depending on the type of food being processed and the possible requirement for washing down. Where fine powders are present, a minimum of IP53 should be used. This should be increased to IP54/65 if the equipment needs to be washed or hosed down. If the equipment should be washed with a jet of hot or cold water under high pressure, it is possible that the IP 65 rating is insufficient and that the IP69K is required
<b>Dump trucks, cement mixers, food industry, car wash</b>	In these high-pressure, high-temperature wash-down applications, enclosures must not only be dust tight (IP6X), but also able to withstand high-pressure and steam cleaning. The recommended protection rating is IP69K (DIN40050-9)
<b>Weather proof equipment</b>	If subjected to exposure to any specific weather condition, an agreement between the User and Manufacturer is necessary, with consideration given to specific testing conditions, including the corrosion resisting properties of the enclosure, fittings and cable glands

## IK : Mechanical impact resistance (EN62262)

This mechanical impact is identified by the energy needed to qualify a specified resistance level, which is measured in joules (J). Protection class impact resistance was eventually given previously by the third digit of the IP rating. It was dropped during the 3<sup>rd</sup> edition of IEC60529 (1978), and replaced by an independent marking specified by the EN62262 standard.

Although dropped from the 3<sup>rd</sup> edition of IEC 60529 onwards, and not present in the current EN versions, older enclosure specifications will sometimes be seen with an optional third IP digit denoting impact resistance. Newer enclosures must be coded with an IK rating. However there is not an exact correspondence of values between the old and new standards.

### Obsolete IP third number for mechanical impact resistance

IP third digit	Impact energy (Joules)	Equivalent drop mass and height
0	Unprotected	No test
1	0.225	150 g dropped from 15 cm
2	0.375	250 g dropped from 15 cm
3	0.5	250 g dropped from 20 cm
5	2	500 g dropped from 40 cm
7	6	1.5 kg dropped from 40 cm
9	20	5.0 kg dropped from 40 cm

### IK mechanical impact resistance values





IK number	Impact energy (Joules)	Equivalent drop mass and height
00	Unprotected	No test
01	0.15	200 g dropped from 7.5 cm
02	0.2	200 g dropped from 10 cm
03	0.35	200 g dropped from 17.5 cm
04	0.5	200 g dropped from 25 cm
05	0.7	200 g dropped from 35 cm
06	1	500 g dropped from 20 cm
07	2	500 g dropped from 40 cm
08	5	1.7 kg dropped from 29.5 cm
09	10	5 kg dropped from 20 cm
10	20	5 kg dropped from 40 cm





## Other classifications

NFC 15100 standard also refers to a “water drop” marking that household appliances and lightings can wear depending on their protection rating. This marking is different from the IP marking. Double marking, the water drops and the IP code, is not allowed because the tests are different.

Description	Protected against vertical water drops	Protected against rainfall	Protected against splashing water	Protected against water jets	Protected against immersion up to 1 m
IP equivalent	IPX1	IPX3	IPX4	IPX5	IPX7
Standard logo					

## NEMA (USA) rating equivalences with IP

The United States National Electrical Manufacturers Association (NEMA) also publishes protection ratings for enclosures similar to the IP rating system published by the International Electro-technical Commission (IEC). However, it also dictates other product features not addressed by IP codes, such as corrosion resistance, gasket aging, and construction practices. Thus, while it is possible to map IP Codes to NEMA ratings that satisfy or exceed the IP Code criteria, it is not possible to map NEMA ratings to IP codes, as the IP Code does not mandate the additional requirements. The below table indicates the minimum NEMA rating that satisfies a given IP code, but can only be used in that way, not to map IP to NEMA. North American enclosure rating systems are defined in NEMA 250, UL 50, UL 508, and CSA C22.2 N° 94.

Equivalent IP Code	Min. NEMA Enclosure rating to satisfy IP Code.
IP20	NEMA-1
IP54	NEMA-3
IP66	NEMA-4, NEMA-4X
IP67	NEMA-6
IP68	NEMA-6P

## Corrosion resistance

### Outdoor use of aluminum enclosures

The plastic enclosures and their weather resistance are treated in the catalog N° 3. We will deal here with the corrosion resistance of aluminum housings and accessories. The aluminum used in enclosures is available in two grades: ADC12 boxes for AC currents and 44,300 for flameproof enclosures. Both grades have good resistance to corrosion inside and outside.

## Chemical composition

Material and standards	Si	Cu	Mg	Zn	Mn	Fe	Ni	Sn	Ti	Al
EN AC 44300 DIN 1706 AISi12(Fe)	10.5-13.5	<0.10	-	<0.15	<0.55	<1	-	-	<0.15	Remainder
ADC12 (JIS H5302:2000)	9.6-12.0	1.5-3.5	<0.3	<1.0	<0.5	0.6-0.9	<0.5	<0.2	-	Remainder

## Galvanic corrosion, also called Bimetallic Corrosion

Protective housings may be subject to a special phenomenon which reduces their lifespan, up to the perforation of the envelope or complete locking of the closing screws. This is galvanic corrosion.

Although most standards specify that appropriate safeguards must be taken to avoid galvanic corrosion on aluminum boxes, none advocates any solution or imposes materials or precise compositions of alloys.

Galvanic (Bi-Metallic) corrosion is an electrochemical phenomenon that occurs when dissimilar metals are in contact in the presence of an electrolyte (e.g. water, sea water). This will cause additional corrosion that can occur with other phenomena and uncoupled metals, and its progression is usually much faster.

A difference of potential appears between the two metals depending on both the metal and the solution. Two metals or two different alloys in contact with the same medium generally take two different potentials. If both metals are electrically connected, their difference of potential generates electrochemical reactions and an electric current flow.

The most negative metal (least noble) is positively polarized and the most positive metal is negatively biased. In the vast





majority of cases, this configuration is an increase of the corrosion rate of the corrodible metal most (most negative), and a decrease in the rate of corrosion of the least corrodible metal (most positive).

## Joint conditions necessary for the appearance of a galvanic corrosion couple.

Galvanic corrosion is a function of several different factors that need to be carefully evaluated when assessing the likelihood to have galvanic corrosion.

The simultaneous requirements for bi-metallic corrosion are as follows:

- An electrolyte bridging the two metals
- Electrical contact between the two metals.
- A difference in potential between the metals to enable a significant galvanic current
- A sustained cathodic reaction on the most noble of the two metals.

**NB: If the metals are dry, bimetallic (galvanic) corrosion cannot occur.**

## Electrolyte

The conductivity of electrolyte will also affect the degree of attack.

When the conductivity of the electrolyte is low, the corrosion is localized to the contact zones between the two metals.

When the conductivity of the electrolyte increases, the corroded surface increases.

## Electrical contact between metals

If the electrical contact is prevented between the two metals by interposing an insulator (aluminum oxide, phosphating, paint, oil, etc ...), the current does not run and there is no corrosion

## Electrical potential difference between metals

The higher the value, the greater the electromotive force of the phenomenon. A difference of hundreds of millivolts is likely to result in galvanic corrosion, but a 200-300mV difference is unlikely to be a problem.

The galvanic corrosion potentials of various metals and alloys are listed in a table which gives the metal electrical potential values and are usually measured with respect to the Standard Calomel Electrode (S.C.E.).

"Anodic" metals such as magnesium, zinc and aluminum are more easily corroded metals than "cathodic" ones (titanium, silver, gold).

Corrosion is proportional to the potential difference between two metals.

The values to be considered are the potentials of the metals and alloys which form the couple with respect to the medium in question. These potentials are experimental values and must be distinguished from the standard potentials of thermodynamic tables. Experimental potentials are strongly influenced by parameters such as temperature, agitation and ventilation. In addition, some metals can take two different potentials when in the same environmental conditions according to whether they are active or passive (case of stainless steels in contact with sea water, for example).

These considerations show that it can be difficult to predict trends without the need for experimentation, as many parameters are likely to reverse the polarity of some galvanic couples.

## Aggravation or reduction factors

- **Area ratio of the two metals:** the worst case is when a large cathode surface (the most positive material) is electrically connected to a small anode surface (metal most negative). The corrosion rate of the most negative metal can be multiplied by 100 or by 1000.

For instance, the assembly of a disc thermostat aluminum cup (dia 16mm) on a stainless steel tank will cause a quick corrosion of the cup if the necessary joint conditions are fulfilled.

On the other side, stainless steel screws closing an aluminum case will be much less subject to corrosion if the contact surfaces are minimized.

## Resistance to corrosion of noble metals

- Regardless of its potential, the corrosion resistance of the most noble metal significantly influences the behavior of bimetallic couples. If the most noble metal corrodes, its corrosion products may, by motion, accelerate the corrosion of the most corroding metal. For instance, copper, yet considered as a noble metal and whose galvanic couple with aluminum is small, produces oxides that can corrode aluminum, which is a critical parameter in the design of earth terminals on aluminum housings that accommodate copper conductors.

If the noble metal couple is not corroding (Gold, Platinum), it will not present a risk of galvanic corrosion regardless of the metal that will be associated.

## Sacrificial metal coatings

By applying to the cathode a sacrificial coating having a potential similar to or near that of the anodic member, the galvanic corrosion is reduced.

### Main design rules:

- The sacrificial element should be on the anodic side and smaller.
- Be careful to use fasteners that have intact coatings.

Examples:

- Cadmium plating on steel fasteners holding 2024-T4 aluminum plates, will sacrifice the cadmium instead of corroding the Aluminum. (Potential difference 100 to 200mV)

- Zinc plating on steel fasteners will sacrifice the zinc instead of corroding the Aluminum (Potential difference 100 to 200mV).

**Do not** use nickel plated on steel fasteners as the potential difference (450mV) between nickel and aluminum is too high and will corrode aluminum.

Note: The current trend is the search for an alternative to cadmium because of its toxicity, and its prohibition by the RoHS European Directive



## Some special cases of bimetallic electrochemical couples

### Corrosion risks with galvanized steel and stainless steel in contact

Galvanized steel in contact with stainless steel is not normally considered to be a serious corrosion risk, except possibly in severe (marine type) environments.

In these situations, precautions such as insulating barriers are usually considered adequate to avoid bimetallic corrosion in most practical situations.

### Galvanic corrosion between stainless steel and aluminum

The corrosion potentials of the stainless steels are “cathodics” and located in the “noble” area. The corrosion potentials of aluminum are “Anodic” and located in the “non-noble” area, with a large potential difference. This means that there will be no galvanic corrosion on stainless steel when placed in contact with aluminum while aluminum will corrode.

Although aluminum is anodic to stainless steel, large relative surface areas of aluminum to stainless steel can be acceptable, depending on local conditions.

Stainless steel fasteners in aluminum plates or sheets are normally considered safe, whereas aluminum rivets or bolts holding stainless steel parts together is an unwise combination, as there is a practical risk of corrosion.

Even with no insulation between the metals, there should be little risk of corrosion, in continental weather conditions.

In contrast, in a marine environment, severe localized pitting corrosion to the aluminum treads has been observed where un-insulated stainless steel bolts were used to secure the treads in place.

On the same ladder however, bolts with sound insulating washers did not show any pitting on the surrounding aluminum.

### Mechanical methods of reducing galvanic corrosion between aluminum and stainless steel

- Isolating the two materials by means of an electrical insulating material, like plastic, wherever practical
- Avoid relatively small areas of the less noble metal (Aluminum) and large areas of the more noble metal (Stainless steel).

- The same metal or more noble (Cathodic, higher number in the table) metals should be used for small fasteners and bolts.

- Avoid crevices in stainless steel: In the presence of crevices stainless steels may feature less noble potentials due to oxygen depletion within the crevice. Therefore, coupling a relatively large aluminum area with a small creviced area of a stainless steel part may result in rapid attack of the material within the crevice leading to stainless steel corrosion.

- Exclude electrolyte from around the bimetallic junction e.g by painting. Paint both metals where possible: if impractical paint the most noble metal

- Seal: insure that faying surfaces are water-tight.

- Apply corrosion-inhibiting pastes or compounds under screw heads or bolts inserted into dissimilar metal surfaces whether or not the fasteners have been previously plated or otherwise treated.

- In some instances, it may be feasible to apply an organic coating to the faying surfaces prior to assembly. This would be applicable to joints which are not required to be electrically conductive.

- Where practicable or where it will not interfere with the proposed use of the assembly, the external joint should be coated externally with an effective paint system.

- Avoid threaded joints for materials far apart in the galvanic series

### Galvanic couple limitation by aluminum and stainless steel protection with chemical conversion surface treatments

#### Steel and Stainless steel phosphate coating

The phosphate coating is a conversion process used to form layers obtained by a reaction of the substrate with a selected medium. It is particularly applied to carbon steels and stainless steels. In the case of steel parts, phosphate coating is used primarily to enhance the adhesion of paints.

We distinguish between thin layers of phosphates (0.2-0.8 g/m<sup>2</sup>) mainly composed of iron phosphates, phosphate layers of average thickness (1.5-4 g/m<sup>2</sup>) containing zinc phosphate, and heavy phosphate layers (7-30 g/m<sup>2</sup>).

The latter, consisting of iron, zinc and manganese phosphates, can be used as anticorrosive coating, even in the absence of paint.

In the case of aluminum-stainless steel assemblies, thick and medium phosphate coating on steel parts is recommended. However, the ideal is to treat the two structures by phosphate coating, separately since the processes are different for aluminum and steel.

#### Aluminum phosphate coating

Aluminum phosphating has taken an important place in surface treatments due to the combined use of this metal with steel in the automotive industry. The metal is immersed in a solution of phosphoric acid in which it corrodes.

In the attack of aluminum, the hydrogen is released, causing a local increase of pH and thus the deposition of sparingly soluble triphosphates. Other ions can be added to baths, Zn but also Mn and Ni. The layers obtained, unlike phosphochromate layers that are amorphous, are formed of small crystals of Zn phosphate (Mn Ni). Germination of these crystals is facilitated by immersing the metal in a solution of colloidal titanium phosphate.

#### Aluminum Anodization

Anodizing consists in strengthening the natural oxide film by anodic oxidation. The thick anodizing provides a good galvanic insulation

### Joining metals by non-metallic materials

To be suitable for joining metals, non-metallic materials must be:

- Free of corrosive agents (salts)
- Free of acid or alkaline materials (neutral ph)
- Free of carbon or metallic particles,
- Must not be subject to bio-deterioration



Because of permanent improvement of our products, drawings, descriptions, features used on these data sheets are for guidance only and can be modified without prior advice

- Must not support fungal growth
- Must not absorb water

**Do not use:** non-metallic materials that will initiate corrosion of metals to which they are joined, e.g., cellulosic reinforced plastics, carbon or metal loaded resin materials, asbestos-cement composites.

## Electrochemical couples between aluminum alloys

(Names highlighted in yellow or blue) and other base metals, in a 2% saline solution.

There is no appearance of significant corrosion when the galvanic couple value is less than 300mV

	Pt (Platinum/ Platine)	Au (Gold/ Or)	Ti (Titanium / Titane)	AISI 316L (passive/passif)	Ag (Silver/ Argent)	Ni (Nickel/ Nickel)	Ni Cu 30 (Monel 400)	NiCr15 Fe8 (Inconel 600)	Cu55 Zn23 Ni22 (Arcap)	Cu (Copper/ Cuivre)	Al10 Sn66 Pb34	Cu Zn34 (Brass/ Laiton)	Cu88 Sn12 (Bronze)	Sn (Tin/ Etain)	Pb (Lead / Plomb)	Al Cu Mg1 (Duralumin)	Mild steel / Acier doux	Al Si 10Mg (Alpax H)	Al 99.5 (Aluminium)	Hard steel/ Acier dur	Al Mg5 (Duralinox)	ADC12 (Aluminum alloy)	Cd (Cadmium/ Cadmium)	Fe (Steel / Fer)	Cr (Chromium/ Chrome)	Al Mg Si0.7 (Almasilium)	Sn75 Zn25	Zn (Zinc/ Zinc)	Al PVD (Physical vapor deposition)	Mg (Magnesium)
Pt (Platinum/ Platine)	0	130	250	250	350	430	430	430	450	570	600	650	770	800	840	940	1000	1065	1090	1095	1100	1100	1100	1105	1200	1200	1350	1400	1400	1900
Au (Gold/ Or)	130	0	110	110	220	300	300	300	320	410	470	520	610	670	710	810	870	935	960	965	970	970	970	975	1070	1070	1230	1270	1270	1820
Ti (Titanium / Titane)	250	110	0	0	110	180	180	180	200	320	350	400	520	550	590	690	750	815	840	845	850	850	855	950	950	1100	1150	1150	1700	
AISI 316L (passive/passif)	250	110	0	0	110	180	180	180	200	320	350	400	520	550	590	690	750	815	840	845	850	850	855	950	950	1100	1150	1150	1700	
Ag (Silver/ Argent)	350	220	100	100	0	80	80	80	100	220	250	300	420	450	490	590	650	715	740	745	750	750	755	850	850	1010	1050	1050	1600	
Ni (Nickel/ Nickel)	430	300	180	180	80	0	0	0	20	110	170	220	340	370	410	510	570	635	660	665	670	670	675	770	770	930	970	970	1520	
Ni Cu 30 (Monel 400)	430	300	180	180	80	0	0	0	20	110	170	220	340	370	410	510	570	635	660	665	670	670	675	770	770	930	970	970	1520	
NiCr15 Fe8 (Inconel 600)	430	300	180	180	80	0	0	0	20	110	170	220	340	370	410	510	570	635	660	665	670	670	675	770	770	930	970	970	1520	
Cu55 Zn23 Ni22 (Arcap)	450	320	200	200	100	20	20	20	0	120	150	200	320	350	380	490	550	615	640	645	650	650	655	750	750	910	950	950	1500	
Cu (Copper/ Cuivre)	570	440	320	320	220	140	140	140	120	0	30	80	200	230	270	370	430	495	520	525	530	530	535	630	630	780	830	830	1380	
Al10 Sn66 Pb34	600	470	350	350	250	170	170	170	150	30	0	50	170	200	210	310	400	465	490	495	500	500	505	600	600	760	800	800	1350	
Cu Zn34 (Brass/ Laiton)	650	520	400	400	300	220	220	220	200	80	50	0	120	150	190	290	350	415	410	445	450	450	455	550	550	710	750	750	1300	
Cu88 Sn12 (Bronze)	770	640	520	520	420	340	340	340	320	200	170	120	0	30	70	170	230	295	320	325	330	330	335	430	430	590	630	630	1180	
Sn (Tin/ Etain)	800	670	550	550	450	370	370	370	350	230	200	150	30	0	40	140	200	265	290	295	300	300	300	305	400	400	560	600	600	1150
Pb (Lead / Plomb)	840	710	590	590	490	410	410	410	380	270	240	190	70	40	0	100	160	225	250	255	260	260	260	265	360	360	520	660	660	1110
Al Cu Mg1 (Duralumin)	940	810	690	690	590	510	510	510	490	370	340	290	170	140	100	0	60	125	150	155	160	160	160	165	260	260	420	560	560	1010
Mild steel / Acier doux	1000	870	750	750	650	570	570	570	550	430	400	350	230	200	150	60	0	65	90	95	100	100	100	105	200	200	360	400	400	950
Al Si 10Mg (Alpax H)	1065	935	815	815	715	635	635	635	615	495	465	415	295	265	225	125	65	0	25	30	35	35	35	40	135	135	295	355	355	885
Al 99.5 (Aluminium)	1090	960	840	840	740	660	660	660	640	520	490	440	320	290	250	150	90	25	0	5	10	10	10	15	110	110	270	310	310	860
Hard steel/ Acier dur	1095	965	845	845	745	665	665	665	645	525	495	445	325	295	255	155	95	30	5	0	5	5	5	10	105	105	265	305	305	855
Al Mg5 (Duralinox)	1100	970	850	850	750	670	670	670	650	530	500	450	330	300	260	160	100	35	10	5	0	0	5	100	100	260	300	300	850	
ADC12 (Aluminum alloy)	1100	970	850	850	750	670	670	670	650	530	500	450	330	300	260	160	100	35	10	5	0	0	5	100	100	260	300	300	850	
Cd (Cadmium/ Cadmium)	1100	970	850	850	750	670	670	670	650	530	500	450	330	300	260	160	100	35	10	5	0	0	5	100	100	260	300	300	850	
Fe (Steel / Fer)	1105	975	855	855	755	675	675	675	655	535	505	455	335	305	265	165	105	40	15	10	5	5	5	0	95	95	255	295	295	845
Cr (Chromium/ Chrome)	1200	1070	950	950	850	770	770	770	750	630	600	550	430	400	380	260	200	135	110	105	100	100	100	95	0	160	200	200	750	
Al Mg Si0.7 (Almasilium)	1200	1070	950	950	850	770	770	770	750	630	600	550	430	400	380	260	200	135	110	105	100	100	100	95	0	160	200	200	750	
Sn75 Zn25	1350	1230	1110	1110	1010	930	930	930	910	790	760	710	590	650	520	420	360	295	270	265	260	260	260	225	160	160	0	40	40	590
Zn (Zinc/ Zinc)	1400	1270	1150	1150	1050	970	970	970	950	830	800	750	630	600	560	460	400	335	310	305	300	300	300	295	200	200	40	0	0	550
Zn Al4 (Zamak3/Zamac 3)	1400	1270	1150	1150	1050	970	970	970	950	830	800	750	630	600	560	460	400	335	310	305	300	300	300	295	200	200	40	0	0	550
Al PVD (Physical vapor deposition)	1400	1270	1150	1150	1050	970	970	970	950	830	800	750	630	600	560	460	400	335	310	305	300	300	300	295	200	200	40	0	0	550
Mg (Magnesium)	1900	1820	1700	1700	1600	1600	1600	1600	1520	1500	1390	1300	1180	1150	1110	1010	950	885	860	850	850	850	845	845	845	590	560	560	0	



## Other limitations in the use of aluminum alloys

To avoid ignition hazards due to impact or friction, standards for explosion-proof equipment (IEC 60079-0) restrict the use of aluminum.

### Enclosures for group I:

The total weight of aluminum + magnesium + titanium should not exceed 15% of the total weight (or 6% of the total weight of magnesium + titanium alloys having no aluminum), which eliminates, for that group, most alloys containing aluminum

### Enclosures for Group II:

- For zone 0: the total weight of aluminum + magnesium + titanium + zirconium should not exceed 10% of the total weight (or 7.5% of the total weight of magnesium + titanium + zirconium alloys for not containing aluminum), which eliminates, for this group and this zone most alloys containing aluminum

For zone 1: the weight of magnesium should not exceed 7.5% of the total weight

For zone 2: no specifications



Because of permanent improvement of our products, drawings, descriptions, features used on these data sheets are for guidance only and can be modified without prior advice



Because of permanent improvement of our products, drawings, descriptions, features used on these data sheets are for guidance only and can be modified without prior advice

# Alphabetical and reference tables



Because of permanent improvement of our products, drawings, descriptions, features used on these data sheets are for guidance only and can be modified without prior advice





Because of permanent improvement of our products, drawings, descriptions, features used on these data sheets are for guidance only and can be modified without prior advice

References list	References list	References list	References list	References list
2DPAP6FAN1503P20	66DK12S100712	66YFMB1P	9BFS2	Y038GB100400AO3J
2DPAP6FBN1503P20	66DK12S100714	66YFMB1V	9BFS3	Y038GB100500AO4J
2DPAP6FCN1503P20	66DK12S190708	66YGA1	9BFS4	Y038GB-35035AO6J
2DPAP6FDN1503P20	66DK12S190710	66YGA1F	9BFS5	Y039GB004040AO6J
2DPAP6FEB2503F20	66DK12S190712	6YEBMG004	9BFS6	Y039GB030090AO6J
2DPAP6FFB2503F20	66DK12S190714	6YGPU10200	9BFS7	Y039GB030110AO6J
2DPAP6FGB2503F20	66DK12S230710	6YGSS10200	9BFV1	Y039GB050200AO6J
2DPAP6FHB2503F20	66DK12S230712	6YTPEM04SS	9BFV2	Y039GB050300AO3J
2DPAP6FIB2503F20	66DK12S290708	6YTPEM16C05140	9BFV3	Y039GB100400AO3J
2DPAP6FIB2610G20	66DK12S290710	6YTPEM20C0812	BE3E3	Y039GB100500AO4J
2DPAP6FJB2503F20	66DK12S290712	6YTPEM20PB	TNR60030C20001F6	Y039GB-35035AO6J
2DPAP6FJB2610G20	66DK12S290714	9BBAE10000AFS07A	TSR50030I2000BK6	Y048GB004040I23J
2DPAP6FKB2503F20	66DK12S440708	9BBFPM1342119000	TSS40050I2000BK6	Y048GB004040I30J
2DPAP6FLB2503F20	66DK12S440710	9BBFPME124211900	Y02MAC000060114M	Y048GB004040N23J
66BF1	66DK12S440712	9BBJO100000154A	Y02MAC000060114N	Y048GB004040N30J
66BF3	66DK12S440714	9BBJO100000177A	Y02MAC005035114M	Y048GB030090I09J
66BF4	66DK12S900712	9BBJO100000452A	Y02MAC005035114N	Y048GB030090I23J
66DA0008050400	66DL14P10010065N	9BBJO100004008A	Y02MAC020080114M	Y048GB030090I30J
66DI08500FL	66DL14P10010075N	9BBSI10RA100003A	Y02MAC020080114N	Y048GB030090N09J
66DI12S090S10	66DL14P19010065N	9BBSI10RA100005A	Y02MAC-10020114M	Y048GB030090N23J
66DI12S090S12	66DL14P19010075N	9BFF10	Y02MAC-10020114N	Y048GB030090N30J
66DI12S100S08	66DL14P29010065N	9BFF14	Y02MAC-10050114M	Y048GB030110I09J
66DI12S100S10	66DL14P29010075N	9BFF4	Y02MAC-10050114N	Y048GB030110I23J
66DI12S100S12	66DL14P44010065N	9BFH1	Y02NAC000060114L	Y048GB030110I30J
66DI12S190S08	66DL14P44010075N	9BFH2	Y02NAC000060114P	Y048GB030110N09J
66DI12S190S10	66DR12S10021C000	9BFL1	Y02NAC005035114L	Y048GB030110N23J
66DI12S190S12	66DU	9BFL2	Y02NAC005035114P	Y048GB030110N30J
66DI12S230S10	66PA045000020	9BFL3	Y02NAC020080114L	Y048GB-35035I23J
66DI12S230S12	66RF0231M12	9BFL4	Y02NAC020080114P	Y048GB-35035I30J
66DI12S290S08	66RF07015	9BFL5	Y02NAC-10050114L	Y048GB-35035N23J
66DI12S290S10	66RI1238	9BFL6	Y02NAC-10050114P	Y048GB-35035N30J
66DI12S290S12	66TY001	9BFL7	Y035GB004040QB3J	Y06ME00060A20080
66DI12S440S08	66TY002	9BFM1	Y036GB004040QB3J	Y06ME30090A20110
66DI12S440S10	66TY003	9BFM2	Y038GB004040AO6J	Y06ME30110A20130
66DI12S440S12	66YFHN1N	9BFM3	Y038GB030090AO6J	Y06MS00060A20080
66DK12S090710	66YFHN1P	9BFP1	Y038GB030110AO6J	Y06MS30090A20110
66DK12S100708	66YFHN1V	9BFP2	Y038GB050200AO6J	Y06MS30110A20130
66DK12S100710	66YFMB1N	9BFS1	Y038GB050300AO3J	Y06NE00060C20080



References list	References list	References list	References list	References list
Y06NE30090C20110	Y0B8GD004040N23J	Y102PN6F204040AJ	Y1B2LN6F235035AJ	Y1G8CA400AO3000J
Y06NE30110C20130	Y0B8GD004040N30J	Y102PN6F230090AJ	Y1B2LN6G204040AJ	Y1G8G0040AO6000J
Y08ME00060A20080	Y0B8GD030090I09J	Y102PN6G204040AJ	Y1B2LN6G235035AJ	Y1G8G0060AO6000J
Y08ME30090A20110	Y0B8GD030090I23J	Y102PN6G230090AJ	Y1B2PN6F204040AJ	Y1G8G0090AO6000J
Y08ME30110A20130	Y0B8GD030090I30J	Y108C000060AA80J	Y1B2PN6F235035AJ	Y1G8G3090AO6000J
Y08MS00060A20080	Y0B8GD030090N09J	Y108C000090AA80J	Y1B8G4040AQ3000J	Y1G8G3110AO6000J
Y08MS30090A20110	Y0B8GD030090N23J	Y108C030090AA80J	Y1G2LN6F2000102J	Y1G8G4040AO6000J
Y08MS30110A20130	Y0B8GD030090N30J	Y108C030110AA80J	Y1G2LN6F2040402J	Y1G8G5035AO6000J
Y08NE00060C20080	Y0B8GD030110I09J	Y108G000060AA80J	Y1G2LN6F2300902J	Y1G8G5200AO6000J
Y08NE30090C20110	Y0B8GD030110I23J	Y108G000090AA80J	Y1G2LN6F2301102J	Y1G8G5300AO3000J
Y08NE30110C20130	Y0B8GD030110I30J	Y108G030090AA80J	Y1G2LN6F2350352J	Y1G8GA400AO3000J
Y09ME00060A09080	Y0B8GD030110N09J	Y108G030110AA80J	Y1G2LN6G2000102J	Y1G8GA500AN4000J
Y09ME30090A09110	Y0B8GD030110N23J	Y108L080105A80D	Y1G2LN6G2040402J	Y1G8L0080105AO6D
Y09ME30110A09130	Y0B8GD030110N30J	Y108L090115A80D	Y1G2LN6G2300902J	Y1G8L0090115AO6D
Y09MS00060A09080	Y0B8GD-35035I23J	Y108L110135A80D	Y1G2LN6G2301102J	Y1G8L0110135AO6D
Y09MS30090A09110	Y0B8GD-35035I30J	Y112PN6F204040AJ	Y1G2LN6G2350352J	Y1G8L0130155AO6D
Y09MS30110A09130	Y0B8GD-35035N23J	Y112PN6F230090AJ	Y1G2LP6F2502002J	Y1G8L0150175AO6D
Y09NE00060C09080	Y0B8GD-35035N30J	Y112PN6G204040AJ	Y1G2LP6F2503002J	Y1G8L0175200AO4D
Y09NE30090C09110	Y0B8LD104040N23J	Y112PN6G230090AJ	Y1G2LP6F2A04002J	Y1G8L0220245AO4D
Y09NE30110C09130	Y0B8LD104040N30J	Y118C000060AA80J	Y1G2LP6F2A05002J	Y1G8L0270295AO4D
Y0A8LD104040AO6J	Y0B8LD130090N09J	Y118C000090AA80J	Y1G2PN6F2000102J	Y1G8L0300325AO4D
Y0A8LD130090AO6J	Y0B8LD130090N23J	Y118C030090AA80J	Y1G2PN6F2040402J	Y1I2LN6F2000102J
Y0A8LD130110AO6J	Y0B8LD130090N30J	Y118C030110AA80J	Y1G2PN6F2300902J	Y1I2LN6F2040402J
Y0A8LD135035AO6J	Y0B8LD130110N09J	Y118G000060AA80J	Y1G2PN6F2301102J	Y1I2LN6F2300902J
Y0A8LD150200AO6J	Y0B8LD130110N23J	Y118G000090AA80J	Y1G2PN6F2350352J	Y1I2LN6F2301102J
Y0A8LD150300AO3J	Y0B8LD130110N30J	Y118G030090AA80J	Y1G2PP6F2502002J	Y1I2LN6F2350352J
Y0A8LD1A0400AO3J	Y0B8LD135035N23J	Y118G030110AA80J	Y1G2PP6F2503002J	Y1I2LN6G2000102J
Y0A8LD1A0500AO4J	Y0B8LD135035N30J	Y118L080105AA80D	Y1G2PP6F2A04002J	Y1I2LN6G2040402J
Y0A9LD104040AO6J	Y0B9LD104040N23J	Y118L090115AA80D	Y1G2PP6F2A05002J	Y1I2LN6G2300902J
Y0A9LD130090AO6J	Y0B9LD104040N30J	Y118L110135AA80D	Y1G8C0040AO6000J	Y1I2LN6G2301102J
Y0A9LD130110AO6J	Y0B9LD130090N23J	Y1A2LN6F204040AJ	Y1G8C0060AO6000J	Y1I2LN6G2350352J
Y0A9LD135035AO6J	Y0B9LD130090N30J	Y1A2LN6F235035AJ	Y1G8C0090AO6000J	Y1I2LP6F2502002J
Y0A9LD150200AO6J	Y0B9LD130110N23J	Y1A2LN6G204040AJ	Y1G8C3090AO6000J	Y1I2LP6F2503002J
Y0A9LD150300AO3J	Y0B9LD130110N30J	Y1A2LN6G235035AJ	Y1G8C3110AO6000J	Y1I2LP6F2A04002J
Y0A9LD1A0400AO3J	Y0B9LD135035N23J	Y1A2PN6F204040AJ	Y1G8C4040AO6000J	Y1I2LP6F2A05002J
Y0A9LD1A0500AO4J	Y0B9LD135035N30J	Y1A2PN6F235035AJ	Y1G8C5035AO6000J	Y1I2PN6F2000102J
Y0B8GD004040I23J	Y0D8LD104040QB3J	Y1A8G4040AQ3000J	Y1G8C5200AO6000J	Y1I2PN6F2040402J
Y0B8GD004040I30J	Y0D9LD104040QB3J	Y1B2LN6F204040AJ	Y1G8C5300AO3000J	Y1I2PN6F2300902J

Because of permanent improvement of our products, drawings, descriptions, features used on these data sheets are for guidance only and can be modified without prior advice





Because of permanent improvement of our products, drawings, descriptions, features used on these data sheets are for guidance only and can be modified without prior advice

References list	References list	References list	References list	References list
Y1I2PN6F2301102J	Y1R2PN6F200010FJ	Y1R2PP6F250300HJ	Y1R8CA400AO0823J	Y1R8GA400AO0823J
Y1I2PN6F2350352J	Y1R2PN6F200010GJ	Y1R2PP6F2A0400FJ	Y1R8CA400AO0830J	Y1R8GA400AO0830J
Y1I2PP6F2502002J	Y1R2PN6F204040BJ	Y1R2PP6F2A0400GJ	Y1R8CA400AO0845J	Y1R8GA400AO0845J
Y1I2PP6F2503002J	Y1R2PN6F204040CJ	Y1R2PP6F2A0400HJ	Y1R8CA400AO0860J	Y1R8GA400AO0860J
Y1I2PP6F2A04002J	Y1R2PN6F204040DJ	Y1R2PP6F2A0500FJ	Y1R8CA500AN0830J	Y1R8GA500AN0830J
Y1I2PP6F2A05002J	Y1R2PN6F204040EJ	Y1R2PP6F2A0500GJ	Y1R8CA500AN0845J	Y1R8GA500AN0845J
Y1I8C0040AO6000J	Y1R2PN6F204040FJ	Y1R2PP6F2A0500HJ	Y1R8CA500AN0860J	Y1R8GA500AN0860J
Y1I8C0060AO6000J	Y1R2PN6F204040GJ	Y1R8C0040AO1023J	Y1R8G0040AO1023J	Y1R8L0080105117D
Y1I8C0090AO6000J	Y1R2PN6F230090BJ	Y1R8C0040AO1030J	Y1R8G0040AO1030J	Y1R8L0080105123D
Y1I8C3090AO6000J	Y1R2PN6F230090CJ	Y1R8C0060AO1023J	Y1R8G0060AO1023J	Y1R8L0080105130D
Y1I8C3110AO6000J	Y1R2PN6F230090DJ	Y1R8C0060AO1030J	Y1R8G0060AO1030J	Y1R8L0080105145D
Y1I8C4040AO6000J	Y1R2PN6F230090EJ	Y1R8C0060AO1045J	Y1R8G0060AO1045J	Y1R8L0080105160D
Y1I8C5035AO6000J	Y1R2PN6F230090FJ	Y1R8C0060AO1060J	Y1R8G0060AO1060J	Y1R8L0080105180D
Y1I8C5200AO6000J	Y1R2PN6F230090GJ	Y1R8C0090AO1023J	Y1R8G0090AO1023J	Y1R8L0090115117D
Y1I8C5300AO3000J	Y1R2PN6F230090HJ	Y1R8C0090AO1030J	Y1R8G0090AO1030J	Y1R8L0090115123D
Y1I8CA400AO3000J	Y1R2PN6F230090JJ	Y1R8C0090AO1045J	Y1R8G0090AO1045J	Y1R8L0090115130D
Y1I8G0040AO6000J	Y1R2PN6F230110BJ	Y1R8C0090AO1060J	Y1R8G0090AO1060J	Y1R8L0090115145D
Y1I8G0060AO6000J	Y1R2PN6F230110CJ	Y1R8C3090AO1023J	Y1R8G3090AO1023J	Y1R8L0090115160D
Y1I8G0090AO6000J	Y1R2PN6F230110DJ	Y1R8C3090AO1030J	Y1R8G3090AO1030J	Y1R8L0090115180D
Y1I8G3090AO6000J	Y1R2PN6F230110EJ	Y1R8C3090AO1045J	Y1R8G3090AO1045J	Y1R8L0110135117D
Y1I8G3110AO6000J	Y1R2PN6F230110FJ	Y1R8C3090AO1060J	Y1R8G3090AO1060J	Y1R8L0110135123D
Y1I8G4040AO6000J	Y1R2PN6F230110GJ	Y1R8C3110AO1023J	Y1R8G3110AO1023J	Y1R8L0110135130D
Y1I8G5035AO6000J	Y1R2PN6F230110HJ	Y1R8C3110AO1030J	Y1R8G3110AO1030J	Y1R8L0110135145D
Y1I8G5200AO6000J	Y1R2PN6F230110JJ	Y1R8C3110AO1045J	Y1R8G3110AO1045J	Y1R8L0110135160D
Y1I8G5300AO3000J	Y1R2PN6F230110KJ	Y1R8C3110AO1060J	Y1R8G3110AO1060J	Y1R8L0110135180D
Y1I8GA400AO3000J	Y1R2PN6F235035BJ	Y1R8C4040AO1023J	Y1R8G4040AO1023J	Y1R8L0130155117D
Y1I8GA500AN4000J	Y1R2PN6F235035CJ	Y1R8C4040AO1030J	Y1R8G4040AO1030J	Y1R8L0130155123D
Y1I8L0080105AO6D	Y1R2PN6F235035DJ	Y1R8C4040AO1045J	Y1R8G4040AO1045J	Y1R8L0130155130D
Y1I8L0090115AO6D	Y1R2PN6F235035EJ	Y1R8C5035AO1023J	Y1R8G5035AO1023J	Y1R8L0130155145D
Y1I8L0110135AO6D	Y1R2PN6F235035FJ	Y1R8C5035AO1030J	Y1R8G5035AO1030J	Y1R8L0130155160D
Y1I8L0130155AO6D	Y1R2PN6F235035GJ	Y1R8C5200AO1023J	Y1R8G5200AO1023J	Y1R8L0130155180D
Y1I8L0150175AO6D	Y1R2PP6F250200EJ	Y1R8C5200AO1030J	Y1R8G5200AO1030J	Y1R8L0150175123D
Y1I8L0175200AO4D	Y1R2PP6F250200FJ	Y1R8C5200AO1045J	Y1R8G5200AO1045J	Y1R8L0150175130D
Y1I8L0220245AO4D	Y1R2PP6F250200GJ	Y1R8C5200AO1060J	Y1R8G5200AO1060J	Y1R8L0150175145D
Y1I8L0270295AO4D	Y1R2PP6F250200HJ	Y1R8C5300AO0823J	Y1R8G5300AO0823J	Y1R8L0150175160D
Y1I8L0300325AO4D	Y1R2PP6F250200JJ	Y1R8C5300AO0830J	Y1R8G5300AO0830J	Y1R8L0150175180D
Y1R2PN6F200010CJ	Y1R2PP6F250300FJ	Y1R8C5300AO0845J	Y1R8G5300AO0845J	Y1R8L0175200123D
Y1R2PN6F200010EJ	Y1R2PP6F250300GJ	Y1R8C5300AO0860J	Y1R8G5300AO0860J	Y1R8L0175200130D

# Alphabetical and reference tables



References list	References list	References list	References list	References list
Y1R8L0175200145D	Y1S2PN6F230110HJ	Y1S8C3110AO1030J	Y1S8G3110AO1030J	Y1S8L0110135145D
Y1R8L0175200160D	Y1S2PN6F230110JJ	Y1S8C3110AO1045J	Y1S8G3110AO1045J	Y1S8L0110135160D
Y1R8L0175200180D	Y1S2PN6F230110KJ	Y1S8C3110AO1060J	Y1S8G3110AO1060J	Y1S8L0110135180D
Y1R8L0220245830D	Y1S2PN6F235035BJ	Y1S8C4040AO1023J	Y1S8G4040AO1023J	Y1S8L0130155117D
Y1R8L0220245845D	Y1S2PN6F235035CJ	Y1S8C4040AO1030J	Y1S8G4040AO1030J	Y1S8L0130155123D
Y1R8L0220245860D	Y1S2PN6F235035DJ	Y1S8C4040AO1045J	Y1S8G4040AO1045J	Y1S8L0130155130D
Y1R8L0220245880D	Y1S2PN6F235035EJ	Y1S8C5035AO1023J	Y1S8G5035AO1023J	Y1S8L0130155145D
Y1R8L0270295830D	Y1S2PN6F235035FJ	Y1S8C5035AO1030J	Y1S8G5035AO1030J	Y1S8L0130155160D
Y1R8L0270295845D	Y1S2PN6F235035GJ	Y1S8C5200AO1023J	Y1S8G5200AO1023J	Y1S8L0130155180D
Y1R8L0270295860D	Y1S2PP6F250200EJ	Y1S8C5200AO1030J	Y1S8G5200AO1030J	Y1S8L0150175123D
Y1R8L0270295880D	Y1S2PP6F250200FJ	Y1S8C5200AO1045J	Y1S8G5200AO1045J	Y1S8L0150175130D
Y1R8L0300325830D	Y1S2PP6F250200GJ	Y1S8C5200AO1060J	Y1S8G5200AO1060J	Y1S8L0150175145D
Y1R8L0300325845D	Y1S2PP6F250200HJ	Y1S8C5300AO0823J	Y1S8G5300AO0823J	Y1S8L0150175160D
Y1R8L0300325860D	Y1S2PP6F250200JJ	Y1S8C5300AO0830J	Y1S8G5300AO0830J	Y1S8L0150175180D
Y1R8L0300325880D	Y1S2PP6F250300FJ	Y1S8C5300AO0845J	Y1S8G5300AO0845J	Y1S8L0175200123D
Y1S2PN6F200010CJ	Y1S2PP6F250300GJ	Y1S8C5300AO0860J	Y1S8G5300AO0860J	Y1S8L0175200130D
Y1S2PN6F200010EJ	Y1S2PP6F250300HJ	Y1S8CA400AO0823J	Y1S8GA400AO0823J	Y1S8L0175200145D
Y1S2PN6F200010FJ	Y1S2PP6F2A0400FJ	Y1S8CA400AO0830J	Y1S8GA400AO0830J	Y1S8L0175200160D
Y1S2PN6F204040BJ	Y1S2PP6F2A0400GJ	Y1S8CA400AO0845J	Y1S8GA400AO0845J	Y1S8L0175200180D
Y1S2PN6F204040CJ	Y1S2PP6F2A0400HJ	Y1S8CA400AO0860J	Y1S8GA400AO0860J	Y1S8L0220245830D
Y1S2PN6F204040DJ	Y1S2PP6F2A0500FJ	Y1S8CA500AN0830J	Y1S8GA500AN0830J	Y1S8L0220245845D
Y1S2PN6F204040EJ	Y1S2PP6F2A0500GJ	Y1S8CA500AN0845J	Y1S8GA500AN0845J	Y1S8L0220245860D
Y1S2PN6F204040FJ	Y1S2PP6F2A0500HJ	Y1S8CA500AN0860J	Y1S8GA500AN0860J	Y1S8L0220245880D
Y1S2PN6F204040GJ	Y1S8C0040AO1023J	Y1S8G0040AO1023J	Y1S8L0080105117D	Y1S8L0270295830D
Y1S2PN6F230090BJ	Y1S8C0040AO1030J	Y1S8G0040AO1030J	Y1S8L0080105123D	Y1S8L0270295845D
Y1S2PN6F230090CJ	Y1S8C0060AO1023J	Y1S8G0060AO1023J	Y1S8L0080105130D	Y1S8L0270295860D
Y1S2PN6F230090DJ	Y1S8C0060AO1030J	Y1S8G0060AO1030J	Y1S8L0080105145D	Y1S8L0270295880D
Y1S2PN6F230090EJ	Y1S8C0060AO1045J	Y1S8G0060AO1045J	Y1S8L0080105160D	Y1S8L0300325830D
Y1S2PN6F230090FJ	Y1S8C0060AO1060J	Y1S8G0060AO1060J	Y1S8L0080105180D	Y1S8L0300325845D
Y1S2PN6F230090GJ	Y1S8C0090AO1023J	Y1S8G0090AO1023J	Y1S8L0090115117D	Y1S8L0300325860D
Y1S2PN6F230090HJ	Y1S8C0090AO1030J	Y1S8G0090AO1030J	Y1S8L0090115123D	Y1S8L0300325880D
Y1S2PN6F230090JJ	Y1S8C0090AO1045J	Y1S8G0090AO1045J	Y1S8L0090115130D	Y1U1BA015095B20L
Y1S2PN6F230110BJ	Y1S8C0090AO1060J	Y1S8G0090AO1060J	Y1S8L0090115145D	Y1U1BA015095B30L
Y1S2PN6F230110CJ	Y1S8C3090AO1023J	Y1S8G3090AO1023J	Y1S8L0090115160D	Y1U1BA025165B20L
Y1S2PN6F230110DJ	Y1S8C3090AO1030J	Y1S8G3090AO1030J	Y1S8L0090115180D	Y1U1BA-10130B20L
Y1S2PN6F230110EJ	Y1S8C3090AO1045J	Y1S8G3090AO1045J	Y1S8L0110135117D	Y1U1CA015095B20L
Y1S2PN6F230110FJ	Y1S8C3090AO1060J	Y1S8G3090AO1060J	Y1S8L0110135123D	Y1U1CA015095B30L
Y1S2PN6F230110GJ	Y1S8C3110AO1023J	Y1S8G3110AO1023J	Y1S8L0110135130D	Y1U1CA025165B20L

Because of permanent improvement of our products, drawings, descriptions, features used on these data sheets are for guidance only and can be modified without prior advice



Because of permanent improvement of our products, drawings, descriptions, features used on these data sheets are for guidance only and can be modified without prior advice

References list	References list	References list	References list	References list
Y1U1CA-10130B20L	Y2H8GD030090AA8J	Y2U8GB030110AZ67	YF43NC30110308UJ	YF4GNC30110301ZJ
Y1U1RA015095B20L	Y2H8GD030110AA8J	Y2W8GB030090AA66	YF43NC30110458UJ	YF4GNC30110451ZJ
Y1U1RA015095B30L	Y2K8GD004040QB3J	Y2W8GB030090AA67	YF43NC30110608UJ	YF4GNC30110601ZJ
Y1U1RA025165B20L	Y2M8GD004040AO6J	Y2W8GB030110AA66	YF44NC04040118UJ	YF4LNC25080823UD
Y1U1RA-10130B20L	Y2M8GD030090AO6J	Y2W8GB030110AZ67	YF44NC04040178UJ	YF4LNC25080830UD
Y1U1UA015095B20L	Y2M8GD030110AO6J	YF42NC04040118UJ	YF44NC04040238UJ	YF4LNC25080845UD
Y1U1UA015095B30L	Y2M8GD035035AO6J	YF42NC04040178UJ	YF44NC04040308UJ	YF4LNC25080860UD
Y1U1UA025165B20L	Y2M8GD050200AO6J	YF42NC04040238UJ	YF44NC04040458UJ	YF4LNC25090823UD
Y1U1UA-10130B20L	Y2M8GD050300AO3J	YF42NC04040308UJ	YF44NC04040608UJ	YF4LNC25090830UD
Y1X1XA025165B20L	Y2M8GD0A0400AO3J	YF42NC04040458UJ	YF44NC30090118UJ	YF4LNC25090845UD
Y1Y1DA015095B20L	Y2M8GD0A0500AO4J	YF42NC04040608UJ	YF44NC30090178UJ	YF4LNC25090860UD
Y1Y1DA015095B30L	Y2P8GD030090AA8J	YF42NC30090118UJ	YF44NC30090238UJ	YF4LNC25110823UD
Y1Y1DA025165B20L	Y2P8GD030110AA8J	YF42NC30090178UJ	YF44NC30090308UJ	YF4LNC25110830UD
Y1Y1DA-10130B20L	Y2T2GC000010NP2J	YF42NC30090238UJ	YF44NC30090458UJ	YF4LNC25110845UD
Y1Y1XA015095B20L	Y2T2GC004040NP2J	YF42NC30090308UJ	YF44NC30090608UJ	YF4LNC25110860UD
Y1Y1XA015095B30L	Y2T2GC020125NP2J	YF42NC30090458UJ	YF44NC30110118UJ	YF52NCS04040451P
Y1Y1XA-10130B20L	Y2T2GC030090NP2J	YF42NC30090608UJ	YF44NC30110178UJ	YF52NCS04040601P
Y22D7J00806USUSA	Y2T2GC030110NP2J	YF42NC30110118UJ	YF44NC30110238UJ	YF52NCS30090451P
Y22D7K01006USUSA	Y2T2GC035035NP2J	YF42NC30110178UJ	YF44NC30110308UJ	YF52NCS30090601P
Y22D7K02006USUSA	Y2T2GD000010NP2J	YF42NC30110238UJ	YF44NC30110458UJ	YF52NCS30110451P
Y22D7K03006USUSA	Y2T2GD004040NP2J	YF42NC30110308UJ	YF44NC30110608UJ	YF52NCS30110601P
Y22D7K07006USUSA	Y2T2GD020125NP2J	YF42NC30110458UJ	YF4GNC00060231ZJ	YF52PCS04040451P
Y22D7L01006USUSA	Y2T2GD030090NP2J	YF42NC30110608UJ	YF4GNC00060301ZJ	YF52PCS04040601P
Y22D9J00806USUSA	Y2T2GD030110NP2J	YF43NC04040118UJ	YF4GNC00060451ZJ	YF52PCS30090451P
Y22D9K01006USUSA	Y2T2GD035035NP2J	YF43NC04040178UJ	YF4GNC00060601ZJ	YF52PCS30090601P
Y22D9K02006USUSA	Y2T3GC030110PP2J	YF43NC04040238UJ	YF4GNC00090231ZJ	YF52PCS30110451P
Y22D9K03006USUSA	Y2T3GC050200PP2J	YF43NC04040308UJ	YF4GNC00090301ZJ	YF52PCS30110601P
Y22D9K07006USUSA	Y2T3GC050300RF2J	YF43NC04040458UJ	YF4GNC00090451ZJ	YF52PPS04040451P
Y22D9L01006USUSA	Y2T3GC0A0400RF2J	YF43NC04040608UJ	YF4GNC00090601ZJ	YF52PPS04040601P
Y2B8GD004040QB3J	Y2T3GC0A0500RF2J	YF43NC30090118UJ	YF4GNC04040231ZJ	YF52PPS30090451P
Y2D8GD004040AO6J	Y2T3GD030110PP2J	YF43NC30090178UJ	YF4GNC04040301ZJ	YF52PPS30090601P
Y2D8GD030090AO6J	Y2T3GD050200PP2J	YF43NC30090238UJ	YF4GNC04040451ZJ	YF52PPS30110451P
Y2D8GD030110AO6J	Y2T3GD050300RF2J	YF43NC30090308UJ	YF4GNC04040601ZJ	YF52PPS30110601P
Y2D8GD035035AO6J	Y2T3GD0A0400RF2J	YF43NC30090458UJ	YF4GNC30090231ZJ	YF52VVS04040451P
Y2D8GD050200AO6J	Y2T3GD0A0500RF2J	YF43NC30090608UJ	YF4GNC30090301ZJ	YF52VVS04040601P
Y2D8GD050300AO3J	Y2U8GB030090AA66	YF43NC30110118UJ	YF4GNC30090451ZJ	YF52VVS30090451P
Y2D8GD0A0400AO3J	Y2U8GB030090AA67	YF43NC30110178UJ	YF4GNC30090601ZJ	YF52VVS30090601P
Y2D8GD0A0500AO4J	Y2U8GB030110AA66	YF43NC30110238UJ	YF4GNC30110231ZJ	YF52VVS30110451P



References list	References list	References list	References list	References list
YF52VVS30110601P	YF5GPCS30090601P	YF82NC30090308UJ	YF8GNC30090026ZJ	YF94NC301102051J
YF53NCS04040451P	YF5GPCS30110451P	YF82NC30090458UJ	YF8GNC30090036ZJ	YF94NC350352051J
YF53NCS04040601P	YF5GPCS30110601P	YF82NC30090608UJ	YF8GNC30090046ZJ	YF94NC502002051J
YF53NCS30090451P	YF5GPPS00060451P	YF82NC30110118UJ	YF8GNC30090056ZJ	YF94NC503002051J
YF53NCS30090601P	YF5GPPS00060601P	YF82NC30110178UJ	YF8GNC30110026ZJ	YF94NCA04002051J
YF53NCS30110451P	YF5GPPS04040451P	YF82NC30110238UJ	YF8GNC30110036ZJ	YF94NCA05002051J
YF53NCS30110601P	YF5GPPS04040601P	YF82NC30110308UJ	YF8GNC30110046ZJ	YF95NC000102051J
YF53PCS04040451P	YF5GPPS30090451P	YF82NC30110458UJ	YF8GNC30110056ZJ	YF95NC000902051J
YF53PCS04040601P	YF5GPPS30090601P	YF82NC30110608UJ	YF8LNC25080026ZJ	YF95NC040402051J
YF53PCS30090451P	YF5GPPS30110451P	YF83NC04040118UJ	YF8LNC25080036ZJ	YF95NC301102051J
YF53PCS30090601P	YF5GPPS30110601P	YF83NC04040178UJ	YF8LNC25080046ZJ	YF95NC350352051J
YF53PCS30110451P	YF5GVVS00060451P	YF83NC04040238UJ	YF8LNC25080056ZJ	YF95NC502002051J
YF53PCS30110601P	YF5GVVS00060601P	YF83NC04040308UJ	YF8LNC25090026ZJ	YF95NC503002051J
YF53PPS04040451P	YF5GVVS04040451P	YF83NC04040458UJ	YF8LNC25090036ZJ	YF95NCA04002051J
YF53PPS04040601P	YF5GVVS04040601P	YF83NC04040608UJ	YF8LNC25090046ZJ	YF95NCA05002051J
YF53PPS30090451P	YF5GVVS30090451P	YF83NC30090118UJ	YF8LNC25090056ZJ	YF9GNC00060156ZJ
YF53PPS30090601P	YF5GVVS30090601P	YF83NC30090178UJ	YF8LNC25110026ZJ	YF9GNC00090156ZJ
YF53PPS30110451P	YF5GVVS30110451P	YF83NC30090238UJ	YF92NC000102051J	YF9GNC04040156ZJ
YF53PPS30110601P	YF5GVVS30110601P	YF83NC30090308UJ	YF92NC000902051J	YF9GNC10040156ZJ
YF53VVS04040451P	YF62NC00010000J	YF83NC30090458UJ	YF92NC040402051J	YF9GNC30090156ZJ
YF53VVS04040601P	YF62NC04040000J	YF83NC30090608UJ	YF92NC301102051J	YF9GNC30110156ZJ
YF53VVS30090451P	YF62NC35035000J	YF83NC30110118UJ	YF92NC350352051J	YF9GNC35035156ZJ
YF53VVS30090601P	YF63NC00010000J	YF83NC30110178UJ	YF92NC502002051J	YF9GNC50200156ZJ
YF53VVS30110451P	YF63NC04040000J	YF83NC30110238UJ	YF92NC503002051J	YF9GNC50300153ZJ
YF53VVS30110601P	YF63NC35035000J	YF83NC30110308UJ	YF92NCA04002051J	YF9GNCA0400153ZJ
YF5GNCS00060451P	YF65NC00010000J	YF83NC30110458UJ	YF92NCA05002051J	YF9GNCA0500144ZJ
YF5GNCS00060601P	YF65NC04040000J	YF83NC30110608UJ	YF93NC000102051J	YF9LNC25080156ZD
YF5GNCS04040451P	YF65NC35035000J	YF8GNC00060026ZJ	YF93NC000902051J	YF9LNC25090156ZD
YF5GNCS04040601P	YF7GNC04040023ZJ	YF8GNC00060036ZJ	YF93NC040402051J	YF9LNC25110156ZD
YF5GNCS30090451P	YF82NC04040118UJ	YF8GNC00060046ZJ	YF93NC301102051J	YF9LNC25130156ZD
YF5GNCS30090601P	YF82NC04040178UJ	YF8GNC00060056ZJ	YF93NC350352051J	YF9LNC25150156ZD
YF5GNCS30110451P	YF82NC04040238UJ	YF8GNC00090026ZJ	YF93NC502002051J	YF9LNC25175156ZD
YF5GNCS30110601P	YF82NC04040308UJ	YF8GNC00090036ZJ	YF93NC503002051J	YF9LNC25220156ZD
YF5GPCS00060451P	YF82NC04040458UJ	YF8GNC00090046ZJ	YF93NCA04002051J	YF9LNC25270156ZD
YF5GPCS00060601P	YF82NC04040608UJ	YF8GNC00090056ZJ	YF93NCA05002051J	YF9LNC25300156ZD
YF5GPCS04040451P	YF82NC30090118UJ	YF8GNC25110036ZJ	YF94NC000102051J	
YF5GPCS04040601P	YF82NC30090178UJ	YF8GNC25110046ZJ	YF94NC000902051J	
YF5GPCS30090451P	YF82NC30090238UJ	YF8GNC25110056ZJ	YF94NC040402051J	

Because of permanent improvement of our products, drawings, descriptions, features used on these data sheets are for guidance only and can be modified without prior advice



# Mechanical thermostats for room temperature control



Because of permanent improvement of our products, drawings, descriptions, features used on these data sheets are for guidance only and can be modified without prior advice



# Y0 range - IP20 to IP44 enclosures and thermostatic controls

## Electrical cabinet ambient temperature thermostats, Din Rail mounting

### Type Y02N

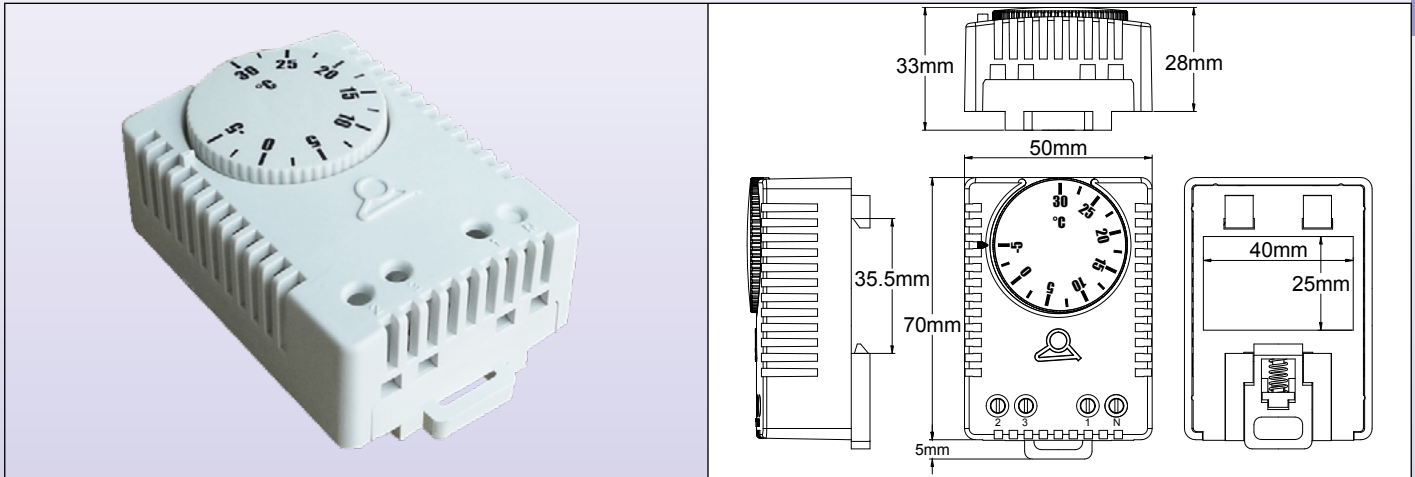

#### Main use:

These models have been designed to control the temperature inside electrical cabinets, being mounted on their DIN rail. Their SPDT contact allows their use to control a cabinet heater, a fan, or a cooling system. The anticipation function allows to select 2 different values for the differential.

**Temperature ranges:** -10+50°C (15-120°F); -5+30°C (23-86°F); 0+60°C (30-140°F); +20+80°C (70-180°F)

**Set point adjustment:** °C or °F printed knob

**Sensing element:** bimetal

**Contact type:** snap-action contact, open or close on temperature rise, 10(2)A 125/250V alt.

**Electrical life:** >10,000 cycles at rated values

**Contact resistance:** <10mOhm

**Electrical connection:** 4 screw terminals, for 1.5mm<sup>2</sup> wires. Neutral terminal must be used only when thermal anticipation is needed (reduced differential)

**Attention:** in standard, thermal anticipator (TA) is wired for use in 230V

**Mounting:** by clip for 35mm DIN rail, EN50022

**Casing:** UL94 V0, PC-ABS, RAL 1010 light grey

**Dimensions:** 70 × 50 × 33mm

**Operating temperature range:** -20 to +80°C (-4+176°F)

**Ingress protection:** IP30

#### Main references ( with 230V thermal anticipator)\*

°C types			
Temperature range (°C)	Differential °C thermal anticipator not connected	Differential °C thermal anticipator connected	References
-10+50°C	6°C±3°C	4°C±2°C	Y02NAC-10050114L
-5+30°C	6°C±3°C	4°C±2°C	Y02NAC005035114L
0+60°C	6°C±3°C	4°C±2°C	Y02NAC000060114L
+20+80°C	6°C±3°C	4°C±2°C	Y02NAC020080114L

°F types			
Temperature range (°F)	Differential °F thermal anticipator not connected	Differential °F thermal anticipator connected	References
15-120°F	11±4°F	7±3°F	Y02NAC-10050114P
23-86°F	11±4°F	7±3°F	Y02NAC005035114P
30-140°F	11±4°F	7±3°F	Y02NAC000060114P
70-180°F	11±4°F	7±3°F	Y02NAC020080114P

\* Type with 115V thermal anticipator: replace 114 in the reference by 115

\* Type with 24V thermal anticipator: replace 114 in the reference by 112

#### Wiring diagram

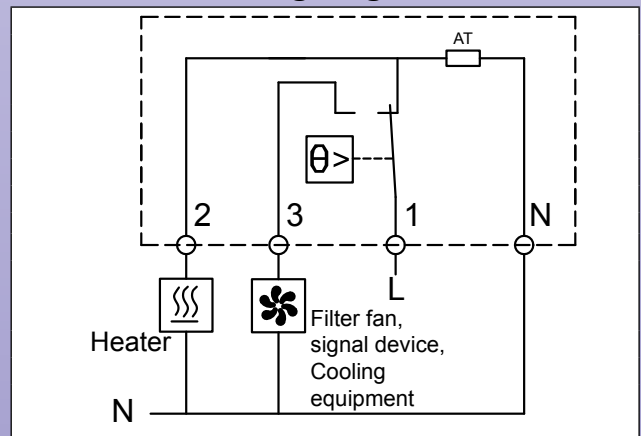



# Y0 range - IP20 to IP44 enclosures and thermostatic controls



## Miniature room temperature thermostats wall mounting, home appliance style

### Type Y02M

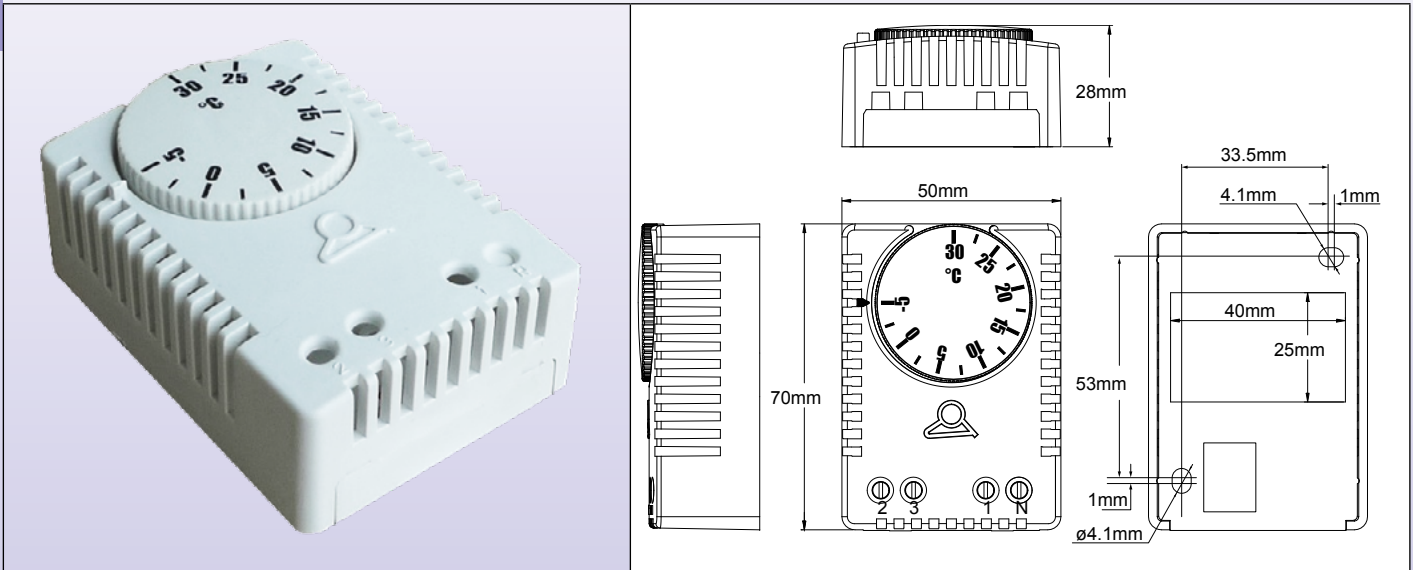

#### Main use:

These models have been designed to control electrical equipment temperature. They are designed for wall mounting with 2 backside screws. Their SPDT contact allows their use to control a cabinet heater, a fan or a filter fan, or a cooling system.

**Temperature ranges:** -10+50°C (14+ 122°F); 0-60°C (32-140°F); 20+80°C (68-176°F)

**Set point adjustment:** screw driver knob, red color for open on rise models, blue color for close on rise models

**Sensing element:** bimetal

**Contact type:** snap-action contact, open or close on temperature rise, 10(2)A 250VAC, 15(2)A 120VAC

**Electrical life:** >100,000 cycles at rated values

**Contact resistance:** <10mOhm

**Electrical connection:** 4 screw terminals, for 1.5mm<sup>2</sup> wires

**Mounting:** Clip for 35mm DIN rail (EN50022)

**Casing:** UL94 V0, PC-ABS, RAL 1010 light grey

**Dimensions:** 67 × 50 × 46mm

**Operating temperature range:** -20 to +80°C

**Ingress protection:** IP30

#### Main references

°C		
Temperature range (°C)	Differential (°C)	References
-10+50°C	4°C±2°C	Y02MAC-10050114M
-10+20°C	4°C±2°C	Y02MAC-10020114M
+5+35°C	4°C±2°C	Y02MAC005035114M
0+60°C	4°C±2°C	Y02MAC000060114M
+20+80°C	4°C±2°C	Y02MAC020080114M
°F		
Temperature range (°F)	Differential (°F)	References
15-120°F	7±3°F	Y02MAC-10050114N
15-70°F	7±3°F	Y02MAC-10020114N
40-95°F	7±3°F	Y02MAC005035114N
30-140°F	7±3°F	Y02MAC000060114N
70-180°F	7±3°F	Y02MAC020080114N

#### Wiring diagram

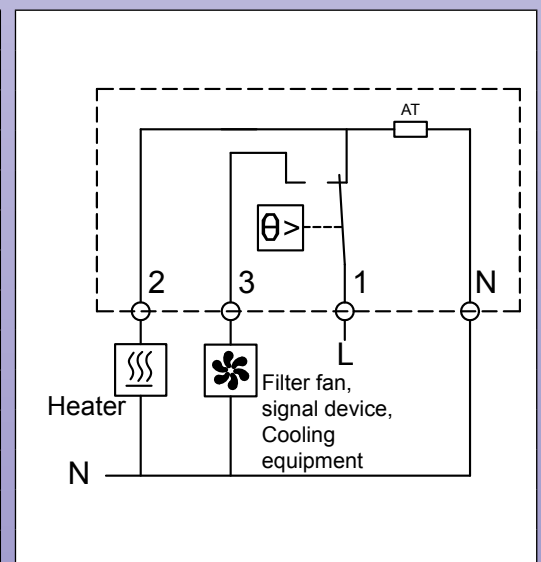

Because of permanent improvement of our products, drawings, descriptions, features used on these data sheets are for guidance only and can be modified without prior advice





## Thermostats with IP65 plastic housings, Type Y2

### Fixed setting ambiance or antifreeze thermostat, IP65, cable gland output, without pilot lights

#### Type Y22D7

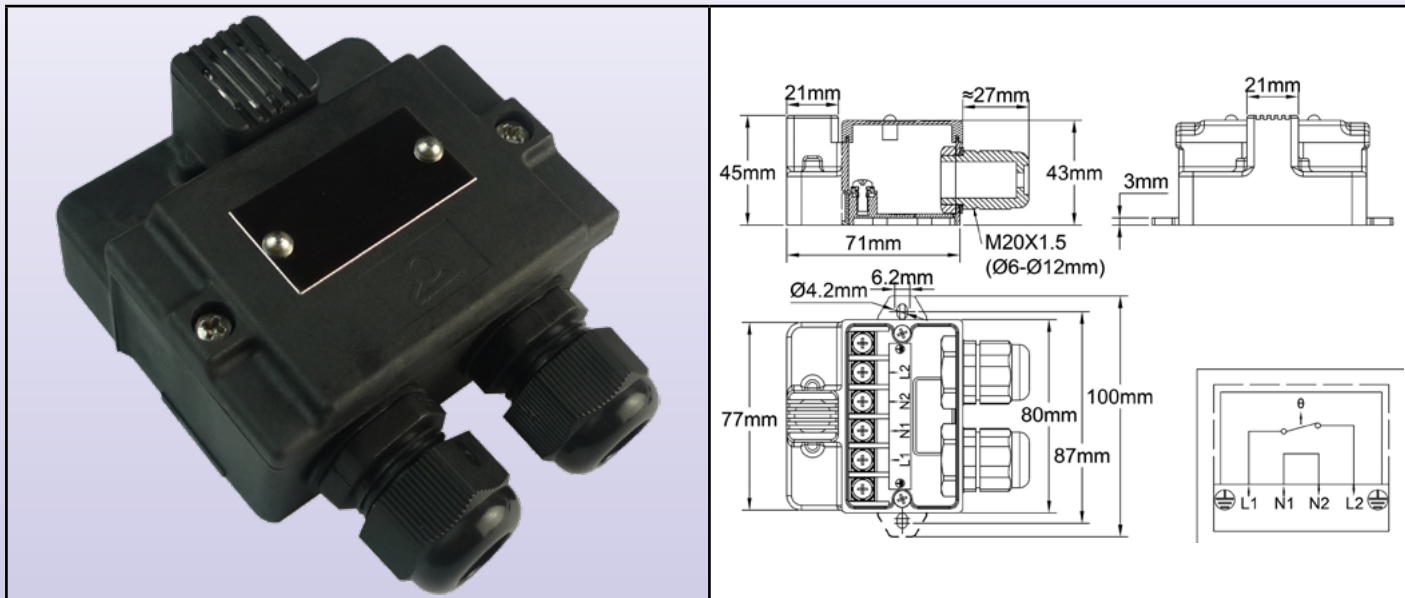

In these boxes, the thermostat, bimetal disc type, is over-molded, and is thermally insulated from the wall on which it is mounted. Its temperature sensing cup is mechanically protected by a grid. It is located in front of the enclosure to be in an area of natural circulation of air.

**Mounting:** Wall, by external side brackets. These tabs can be folded inwards. There also is the opportunity to practice two mounting holes inside for wall mounting (Note: in this case the ingress protection class IP65 on the rear wall is lost)

**Protection:** IP65 (IK 03 On thermostat guard, IK10 the rest of the housing)

**Material:** ABS-PC black glass-fiber reinforced

**Screws:** Stainless steel, captive

**Output:** 2 Cable glands M20, PA66, IP66, for cable from 6 to 12mm dia.

**Electrical rating:** Single pole, 8 to 16A 250V (100000 cycles). Contact style can be open on rise or close on rise.

**Identification:** The cover can be fitted with a 20 × 40mm riveted stainless steel identification plate (standard) or with a sticker (Option)

**Customization:** On request (MOQ apply)

**Connection:** Built in 4mm<sup>2</sup> screw terminal block

**Options:**

- Other calibration temperatures
- Cream color housing
- Incorporation of a temperature sensor (thermocouple, Pt100 or Pt1000, thermistor)

Calibration temperature °C (°F)	Close temperature °C (°F)	Electrical rating	Main uses	References
8°C (46, 4)	3°C (37, 4)	8A 250V	Ice detection, starts an antifreeze or heating system	Y22D7J00806USUSA
10°C (50)	4°C (39, 2)	10A 250V	Ice detection, starts an antifreeze or heating system	Y22D7K01006USUSA
10°C (50)	4°C (39, 2)	16A 250V	Ice detection, starts an antifreeze or heating system	Y22D7L01006USUSA
30°C (86)	20°C (68)	10A 250V	Over-heating detection in residential premises, heating stop	Y22D7K03006USUSA
20°C (68)	30°C (86)	10A 250V	Over-heating detection in residential premises, alarm (NO contact)	Y22D7K02006USUSA
70°C (158)	60°C (140)	10A 250V	Fire detection (withstand sprinklers water sprays)	Y22D7K07006USUSA

Because of permanent improvement of our products, drawings, descriptions, features used on these data sheets are for guidance only and can be modified without prior advice

## Thermostats with IP65 plastic housings, Type Y2



### Fixed setting ambiance or antifreeze thermostat, IP65, cable gland output, two pilot lights

#### Type Y22D9

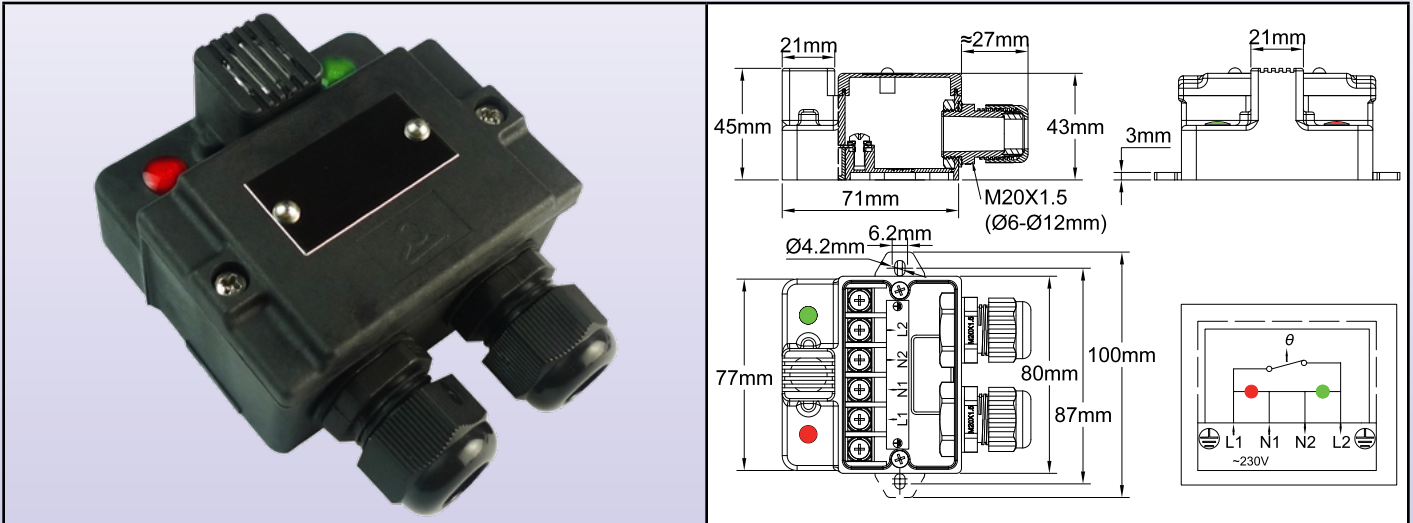

In these boxes, the thermostat, bimetal disc type, is over-molded, and is thermally insulated from the wall on which it is mounted. Its temperature sensing cup is mechanically protected by a grid. It is located in front of the enclosure to be in an area of natural circulation of air.

**Mounting:** Wall, by external side brackets. These tabs can be folded inwards. There also is the opportunity to practice two mounting holes inside for wall mounting (Note: in this case the ingress protection class IP65 on the rear wall is lost)

**Protection:** IP65 (IK 03 On thermostat guard, IK10 the rest of the housing)

**Material:** ABS-PC black glass-fiber reinforced

**Screws:** Stainless steel, captive

**Output:** 2 Cable glands M20, PA66, IP66, for cable 6 to 12mm dia.

**Electrical rating:** Single pole, 8 to 16A 250V (100,000 cycles). Contact style can be open on rise or close on rise.

**Pilot lights:** allow to visualize the power supply and thermostat contact position

**Identification:** The cover can be fitted with a 20x40mm riveted stainless steel identification plate (standard) or with a sticker (Option)

**Customization:** On request (MOQ apply)

**Connection:** Built in 4mm<sup>2</sup> screw terminal block

**Options:**

- Other calibration temperatures
- Cream color housing
- Incorporation of a temperature sensor (thermocouple, Pt100 or Pt1000, thermistor)
- 115V pilot lights

Calibration temperature °C (°F)	Close temperature °C (°F)	Electrical rating	Main uses	References
8°C (46, 4)	3°C (37, 4)	8A 250V	Ice detection, starts an antifreeze or heating system	Y22D9J00806USUSA
10°C (50)	4°C (39, 2)	10A 250V	Ice detection, starts an antifreeze or heating system	Y22D9K01006USUSA
10°C (50)	4°C (39, 2)	16A 250V	Ice detection, starts an antifreeze or heating system	Y22D9L01006USUSA
30°C (86)	20°C (68)	10A 250V	Over-heating detection in residential premises, heating stop	Y22D9K03006USUSA
20°C (68)	30°C (86)	10A 250V	Over-heating detection in residential premises, alarm (NO contact)	Y22D9K02006USUSA
70°C (158)	60°C (140)	10A 250V	Fire detection (withstand sprinklers water sprays)	Y22D9K07006USUSA

Because of permanent improvement of our products, drawings, descriptions, features used on these data sheets are for guidance only and can be modified without prior advice

# Pigtail bulb room thermostats



Because of permanent improvement of our products, drawings, descriptions, features used on these data sheets are for guidance only and can be modified without prior advice

Enclosure	Type	Operation	Contact	Measurement	Ranges °C	Models
IP44	Control	Mechanical	SPDT	Ambient		<b>Y035, Y036</b>
Material						
PC-ABS						

<b>Y035: Internal adjustment</b>		<b>Y036: External adjustment</b>	

**Housing:** IP44, black PC-ABS, fiber glass reinforced, UL94V0. High impact and UV resistance. 2 removable wall mounting lugs.

**Cable input:** One M20 cable gland.

**Set point adjustment:** By °C printed knob for external adjustment models, by screw driver and printed dial on internal adjustment models. °F values available as an option.

**Sensing element:** Liquid filled bulb, coiled on the side of enclosure.

**Adjustment range:** 4-40°C (40-105°F)

**Electrical connections:** 3 screw terminal connection block

**Mounting:** Wall mounting, by two side lugs with holes for dia. 4mm screws, 63mm distance.

**Contact:** SPDT

**Electrical rating, resistive loads:**

- Open on temperature rise contact (C-1)  
16A 250V, 50 ~60Hz: >100,000 cycles,  
20A 250V, 50 ~60Hz: ≥50,000 cycles,  
10A 400V, 50 ~60Hz: ≥50,000 cycles.

- Close on temperature rise contact (C-2)  
(C-2): 6A 250V 50 ~60Hz: >100,000 cycles

**Electrical rating, inductive loads:**

- Open on temperature rise contact (C-1): 6A 250V, 50 ~60Hz: >100,000 cycles
- Close on temperature rise contact (C-2): 0.6A 250V 50 ~60Hz: >100,000 cycles.

**Minimum storage temperature:** -35°C (-30°F)

**Maximum ambient temperature:** 60°C (140°F)

For more technical information ask 8G thermostat technical data sheet.

## References

Temperature ranges °C (°F)	Internal adjustment	External adjustment	Differential °C (°F)	Max temperature on bulb °C (°F)
4-40 (40-105)	Y035GB004040QB3J	Y036GB004040QB3J	1±0.5°C (1.8±1°F)	60 (140)

°F printing: replace last character (J) by K

## Knob printings

°C/°F Printing	
4-40°C	40-105°F

# "Pigtail" bulb room thermostat, with built-in pilot light and 2 M20 cable glands for heat tracing application



Enclosure	Type	Operation	Contact	Measurement	Ranges °C	Models
IP55	Control	Mechanical	SPNC	Ambient		<b>Y0D8, Y0D9</b>
Material						
PC-ABS						

## Y0D8: External adjustment

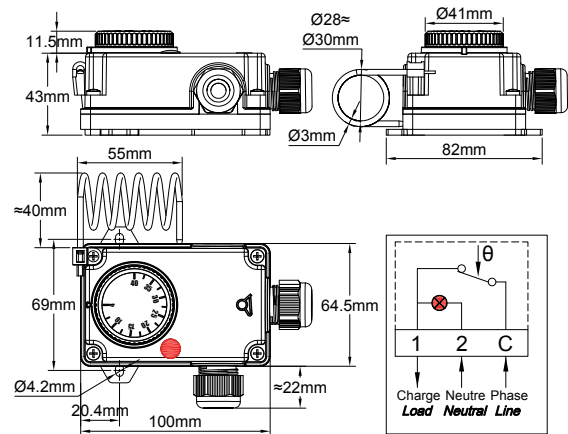

## Y0D9: Internal adjustment

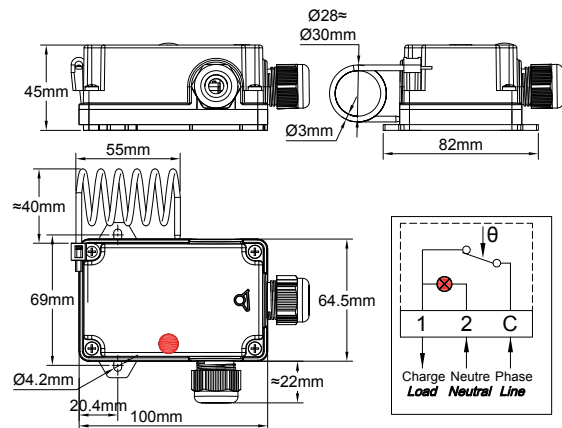

Example of wall mounting model connected on Y25 connection boxes for antifreeze protection of livestock waters

Example of assembly on Y29 connection box with pipe mounting leg

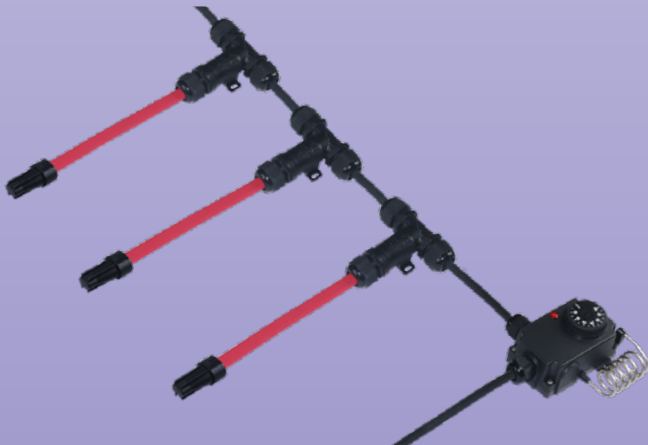



# "Pigtail" bulb room thermostat, with built-in pilot light and 2 M20 cable glands for heat tracing application



## Applications

Ambient temperature control in professional premises where good protection against liquid splashes or dust is requested.

Output with 2 cable glands, allowing of heat tracing cables for freeze protection.

The connection of one heating cable can be done directly. For the connection of several heating cables, it is necessary to go through an intermediate box of types Y25, Y26, Y28, Y29 (See pages of these products)

## Main features

**Housing:** Reduced height, IP44, black PC-ABS fiberglass reinforced, UL94V0. High impact and UV resistance. 2 removable wall mounting lugs.

**Cable input:** Two M20 cable glands. Mounting of cable glands can be modified in 3 positions. **Special cable glands for oblong heat tracing cables are available on request. Available models are described on pages of 6YTP products**

**Set point adjustment:** By °C printed knob for external adjustment models, by screw driver and printed dial on internal adjustment models. °F values available as an option.

**Sensing element:** Liquid filled "pigtail" bulb, mounted on the side of plastic housing

**Adjustment ranges:** 4-40°C (40-105°F).

**Electrical connections:** On screw terminals. (It is possible to connect 2 wires 1.5mm<sup>2</sup> on each terminal).

**Mounting:** Wall mounting, by two side lugs with holes for dia. 4mm screws, 69mm distance.

**This thermostat can be mounted directly on the rear side of pipe mounting connection boxes type Y29.**

**Contact:** SPNC (open on temperature rise).

**Pilot light:** Neon, 230V, standard in red, parallel connection on the load

**Electrical rating, resistive loads:**

16A 250V, 50 ~60Hz.

**Minimum storage temperature:** -35°C (-30°F)

**Maximum ambient temperature:** 60°C (140°F).

## Selection of some part numbers with cable gland seals for round cables\*

Temperature ranges °C (°F)	Internal adjustment**	External adjustment**	Differential	Max temperature on bulb
4-40 (40-105)	Y0D9LD104040QB3J	Y0D8LD104040QB3J	1±0.5°C (1.8±1°F)	60°C (140°F)

\* These products also exist with bulb and capillary sensing element: replace Y0D by Y0A in the reference.

\*\* °F printing: replace last character (J) by K

## Knob printings

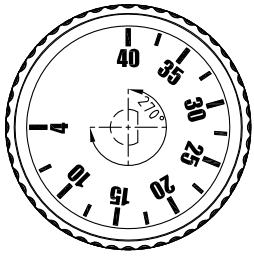
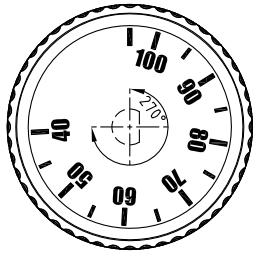
°C Printing	°F Printing
4-40°C	40-105°F
	

## \*Models with bulb and capillary sensing element

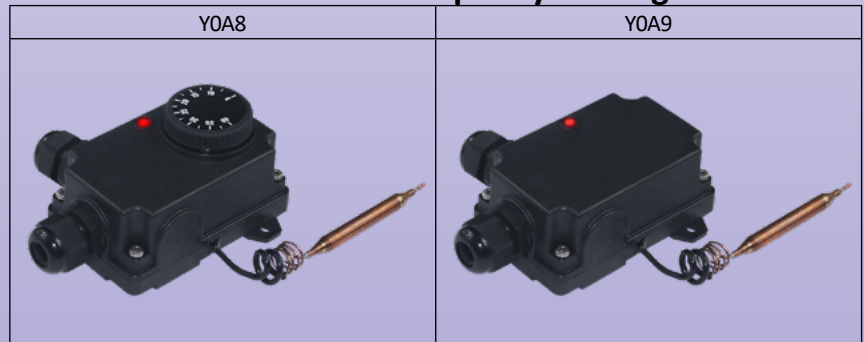

# “Pigtail” bulb room thermostats, with 2 built-in pilot lights



Enclosure	Type	Operation	Contact	Measurement	Ranges °C	Models
IP55	Control	Mechanical	SPNC	Ambient		<h2 style="margin: 0;">Y2B, Y2K</h2>
Material						
PC-ABS						

<p>Y2B: External adjustment</p>		<p>Y2M: Internal adjustment</p>	
---------------------------------	--	---------------------------------	--

**Housing:** PC-ABS, fiberglass reinforced, UL94V0. High impact and UV resistance, with waterproof gasket on thermostat shaft for external adjustment types. Internal adjustment types have a PC transparent cover, to visualize the pilot lights and the set point adjustment.

**Cable input:** M20 cable gland, Black PA66, for cables from 6 to 12mm dia.

**Set point adjustment:** By °C printed knob for external adjustment models, by screw driver and printed dial on internal adjustment models. External adjustment types have an adjustable rotation limit system located inside the knob that allows reducing the set point adjustment span. °F values are available in option.

**Sensing element:** Liquid filled “pigtail” bulb, mounted on the side of plastic housing.

**Temperature adjustment ranges:** -35+35°C (-30+95°F), 4-40°C (40-105°F).

**Pilot lights:** Allow to visualize the power supply and thermostat contact position (230V Phase and Neutral power supply is mandatory for pilot lights)

**Electrical connections:** On screw terminals. (It is possible to connect 2 wires 1.5mm<sup>2</sup> on each terminal). In option, an auxiliary connection block can be added, providing 3 neutral terminals.

**Mounting:** Wall mounting, by two side lugs with holes for dia. 4mm screws, on a 59 × 60mm diagonal.

**Contact:** SPNC (open on temperature rise).

**Electrical rating, resistive loads:**

16A 250V, 50 ~60Hz: >100000 cycles,

20A 250V, 50 ~60Hz: ≥50000 cycles,

10A 400V, 50 ~60Hz: ≥50000 cycles.

**Electrical rating, inductive loads:**

6A 250V, 50 ~60Hz: >100000 cycles

**Minimum Storage temperature:** -35°C (-30°F)

**Maximum ambient temperature:** 60°C (140°F)

For more technical information ask 8G thermostat technical data sheet.

## Main references

Temperature adjustment ranges °C (°F)	4-40 (40-105)
References with external adjustment	Y2B8GD004040QB3J
References with internal adjustment	Y2K8GD004040QB3J
Differential °C (°F)	1.6±1°C (2.9±2°F)

°F printing: replace last character (J) by K

Version with auxiliary 3 way neutral terminal: replace D0 by D1 in the reference.

## Knob printings

°C Printing	°F Printing
4-40°C	40-105°F





# "Pigtail" bulb room thermostats



Enclosure	Type	Operation	Contact	Measurement	Ranges °C	Models
IP66, IK10	Control	Mechanical	SPDT	Ambient		<b>YF7GNC</b>
Material						
PA66 & PC						

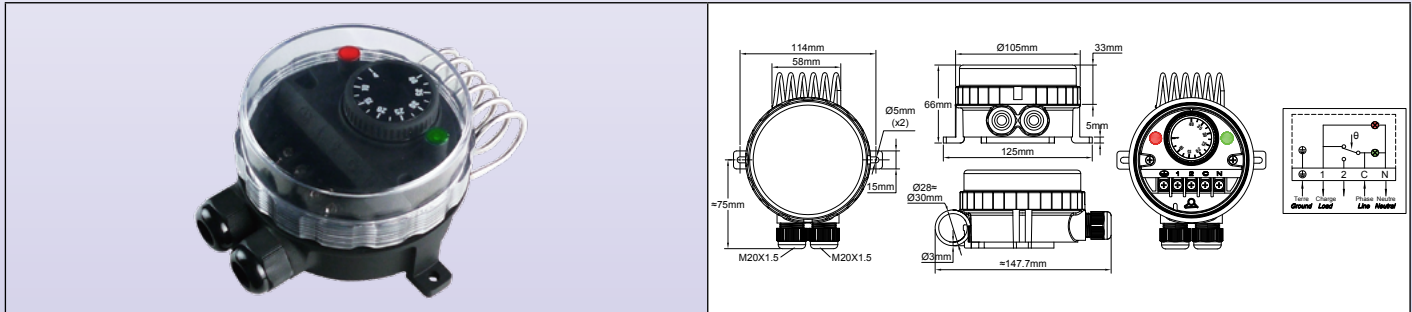

## Applications:

- Equipment requesting a very strong resistance to water ingress. The transparent cover allows to visualize the set point and the 2 pilot lights
- Wall mounting for indoor or outdoor temperature control of cold rooms.
- Temperature control of industrial or commercial premises.
- Outdoor temperature control of antifreeze heaters.
- Green houses and livestock stables temperature control.

**Housing:** Protection class IP 66 upon EN 60529 (waterproof spray water under high pressure and sea splashes, totally dust tight). Body in black PA66, fiber glass reinforced. The transparent polycarbonate cover can be unscrewed by hand, but it is also possible to use a hook spanner. Mechanical impact resistance: IK10. High UV resistance.

**Set point adjustment:** By °C printed knob. All types have an adjustable rotation limit system located inside the knob that allows reducing the set point adjustment span. °F printed knobs available as an option.

**Action:** Temperature control. On-Off action

**Sensing element:** Liquid filled "pigtail" stainless steel bulb, mounted on the top side of the plastic housing.

**Pilot lights:** One pilot light visualizes the thermostat contact output position. The other visualizes the power supply input. Phase and line electrical supply is mandatory for these pilot lights.

**Set point adjustment ranges:** 4-40°C (40-105°F)

**Cable input and output:** Two M20 cable glands, built-in black PA66.

**Electrical connections:** Inside, on screw terminal connection block. It is possible to connect 2 wires 1.5mm<sup>2</sup> on each terminal.

**Earthing:** Internal screw terminal.

**Mounting:** Wall mounting, by 2 legs with holes for screws dia. 4 to 5mm, 114mm distance

**Identification:** Identification label on backside.

**Contact:** SPDT

**Electrical rating, resistive loads:**

- Open on temperature rise contact (C-1)

16A 250V, 50 ~60Hz: >100000 cycles,

20A 250V, 50 ~60Hz: ≥50000 cycles,

10A 400V, 50 ~60Hz: ≥50000 cycles.

- Close on temperature rise contact (C-2): 6A 250V 50 ~60Hz: >100000 cycles

**Electrical rating, inductive loads:**

- Open on temperature rise contact (C-1): 2.6A 250V, 50 ~60Hz: >100000 cycles

- Close on temperature rise contact (C-2): 0.6A 250V 50 ~60Hz: >100000 cycles.

**Minimum storage temperature:** -35°C (-30°F)

**Maximum ambient temperature:** 60°C (140°F)

For more technical information ask 8G thermostat technical data sheet.

## Main references

Temperature adjustment ranges °C (°F)	4-40 (40-105)
Reference	YF7GNC04040023ZJ
Differential °C (°F)	1.6±1°C (2.9±2°F)

°F printing: replace last character (J) by K

## Knob printings

°C Printing	°F Printing
4-40°C	40-105°F



Because of permanent improvement of our products, drawings, descriptions, features used on these data sheets are for guidance only and can be modified without prior advice

# Bulb and capillary mechanical thermostats



Because of permanent improvement of our products, drawings, descriptions, features used on these data sheets are for guidance only and can be modified without prior advice

# Bulb and capillary thermostats



Because of permanent improvement of our products, drawings, descriptions, features used on these data sheets are for guidance only and can be modified without prior advice

Enclosure	Type	Operation	Contact	Measurement	Ranges °C	Models
IP44	Control	Mechanical	SPDT	Remote		<h2>Y038, Y039</h2>
Material						
PC - ABS						

<p><b>Y039: Internal adjustment</b></p>	<p><b>Y038: External adjustment</b></p>	
---	---	--

**Housing:** IP44, black PC-ABS, fiberglass reinforced, UL94V0. High impact and UV resistance. 2 removable wall mounting lugs.

**Electrical input:** One M20 cable gland.

**Set point adjustment:** By °C printed knob for external adjustment models, by screw driver and printed dial on internal adjustment models. °F values available as an option

**Sensing element:** Liquid filled bulb, distance measurement with capillary.

**Temperature adjustment ranges:** -35+35°C (-30+95°F), 4-40°C (40-105°F), 30-90°C (85-195°F), 30-110°C (90-230°F), 50-200°C (120-390°F), 50-300°C (120-570°F), 100-400°C (210-750°F), 100-500°C (210-930°F).

**Electrical connections:** 3 screw terminal connection block

**Mounting:** Wall mounting, by two side lugs with holes for dia. 4mm screws, 63mm distance.

**Contact:** SPDT

**Electrical rating, resistive loads:**

- Open on temperature rise contact (C-1)

16A 250V, 50 ~60Hz: >100000 cycles,

20A 250V, 50 ~60Hz: ≥50000 cycles,

10A 400V, 50 ~60Hz: ≥50000 cycles.

- Close on temperature rise contact (C-2): 6A 250V 50 ~60Hz: >100000 cycles

**Electrical rating, inductive loads:**

- Open on temperature rise contact (C-1): 6A 250V, 50 ~60Hz: >100000 cycles

- Close on temperature rise contact (C-2): 0.6A 250V 50 ~60Hz: >100000 cycles.

**Minimum Storage temperature:** -35°C (-30°F)

**Maximum ambient temperature:** 60°C (140°F)

For more technical information see 8G thermostat technical data sheet

## References

Temperature ranges °C (°F)	Internal adjustment	External adjustment	Bulb diameter (D, mm)	Bulb length (L, mm)	Differential °C (°F)	Max temperature on bulb °C (°F)
-35+35°C (-30+95°F)	Y039GB-35035AO6J	Y038GB-35035AO6J	6	98	1.6±1°C (2.9±2°F)	55 (130)
4-40°C (40-105°F)	Y039GB004040AO6J	Y038GB004040AO6J	6	140	1±0.5°C (1.8±1°F)	60 (140)
30-90°C (85-195°F)	Y039GB030090AO6J	Y038GB030090AO6J	6	87	2.5±1°C (4.5±1.8°F)	120 (250)
30-110°C (90-230°F)	Y039GB030110AO6J	Y038GB030110AO6J	6	93	2.5±1°C (4.5±1.8°F)	150 (300)
50-200°C (120-390°F)	Y039GB050200AO6J	Y038GB050200AO6J	6	59	4±2°C (7±3.6°F)	250 (480)
50-300°C (120-570°F)	Y039GB050300AO3J	Y038GB050300AO3J	3	145	10±5°C (18±9°F)	350 (660)
100-400°C (210-750°F)	Y039GB100400AO3J	Y038GB100400AO3J	3	93	10±5°C (18±9°F)	430 (800)
100-500°C (210-930°F)	Y039GB100500AO4J	Y038GB100500AO4J	4	235	10±5°C (18±9°F)	550 (1000)

°F printing: replace last character (J) by K

# Bulb and capillary thermostats



## Knob printings

°C Printing							
-35+35°C	4-40°C	30-90°C	30-110°C	50-200°C	50-300°C	100-400°C	100-500°C
°F Printing							
-30+95°F	40-105°F	85-195°F	90-230°F	120-390°F	120-570°F	210-750°F	210-930°F

Because of permanent improvement of our products, drawings, descriptions, features used on these data sheets are for guidance only and can be modified without prior advice



# Bulb and capillary thermostats, with built-in pilot light and 2 or 3 M20 cable glands



Because of permanent improvement of our products, drawings, descriptions, features used on these data sheets are for guidance only and can be modified without prior advice

Enclosure	Type	Operation	Contact	Measurement	Ranges °C	Models
IP55	Control	Mechanical	SPNC	Ambient		<h2 style="margin: 0;">Y0A8, Y0A9</h2>
Material						
PC - ABS						

<p><b>Y0A8: External adjustment</b></p>		<p><b>Y0A9: Internal adjustment</b></p>	
---	--	---	--

## Applications

Distance temperature control in professional premises where good protection against liquid splashes or dust is requested. Output with 2 or 3 cable glands, allowing direct connection of heat tracing cables, radiators or immersion heaters.

**Housing:** Reduced height, IP44, black PC-ABS fiberglass reinforced, UL94V0. High impact and UV resistance. 2 removable wall mounting lugs.

**Cable input:** M20 cable glands. Delivered with 2 or 3 cable glands. **Special cable glands for oblong or flat heat tracing cables are available on request.** Positioning the cable glands allows variations in the mounting position.

**Set point adjustment:** By °C printed knob for external adjustment models, by screw driver and printed dial on internal adjustment models. °F values available in option

**Sensing element:** Liquid filled bulb, distance measurement with capillary.

**Temperature adjustment ranges:** -35+35°C (-30+95°F), 4-40°C (40-105°F), 30-90°C (85-195°F), 30-110°C (90-230°F), 50-200°C (120-390°F), 50-300°C (120-570°F), 100-400°C (210-750°F), 100-500°C (210-930°F).

**Capillary length:** 1.5 m

**Electrical connections:** On screw terminals. (It is possible to connect 2 wires 1.5mm<sup>2</sup> on each terminal). **One main terminal and 3 terminals are available for neutral connection. This allows, for example, connecting two heat trace heaters.**

**Mounting:** Wall mounting, by two side lugs with holes for dia. 4mm screws, 69mm distance.

**Pilot light:** Neon, 230V, standard in red, parallel connection on the load

**Contact:** SPNC (open on temperature rise).

**Electrical rating, resistive loads:**

16A 250V, 50 ~60Hz: >100000 cycles, 20A 250V, 50 ~60Hz: ≥50000 cycles, 10A 400V, 50 ~60Hz: ≥50000 cycles.

**Electrical rating, inductive loads:**

6A 250V, 50 ~60Hz: >100000 cycles

**Minimum Storage temperature:** -35°C (-30°F)

**Maximum ambient temperature:** 60°C (140°F)

For more technical information see 8G thermostat technical data sheet

## Main references with 3 cable glands\*





Temperature ranges °C (°F)	Internal adjustment	External adjustment	Bulb diameter (D, mm)	Bulb length (L, mm)	Differential °C (°F)	Max temperature on bulb °C (°F)
-35+35°C (-30+95°F)	Y0A9LD135035AO6J	Y0A8LD135035AO6J	6	98	3±2 (5.5±4)	55 (130)
4-40°C (40-105°F)	Y0A9LD104040AO6J	Y0A8LD104040AO6J	6	140	2.5±1.5 (4.5±2.5)	60 (140)
30-90°C (85-195°F)	Y0A9LD130090AO6J	Y0A8LD130090AO6J	6	87	4±3 (7±5.5)	120 (250)
30-110°C (90-230°F)	Y0A9LD130110AO6J	Y0A8LD130110AO6J	6	93	5±3 (9±7)	150 (300)
50-200°C (120-390°F)	Y0A9LD150200AO6J	Y0A8LD150200AO6J	6	59	8±5 (14±9)	250 (480)
50-300°C (120-570°F)	Y0A9LD150300AO3J	Y0A8LD150300AO3J	3	135	10±5 (18±9)	350 (660)
100-400°C (210-750°F)	Y0A9LD1A0400AO3J	Y0A8LD1A0400AO3J	3	93	15±5 (27±9)	430 (800)
100-500°C (210-930°F)	Y0A9LD1A0500AO4J	Y0A8LD1A0500AO4J	4	235	10±5 (18±9)	550 (1000)

\* 2 cable gland version: replace LD by KD in the reference. °F printing: replace last character (J) by K

# Bulb and capillary thermostats, with built-in pilot light and 2 or 3 M20 cable glands

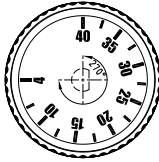
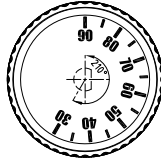
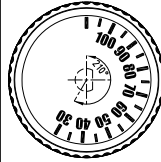
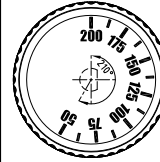
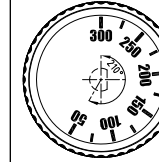
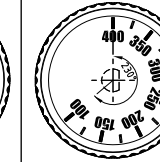
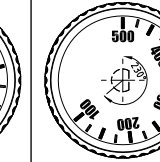

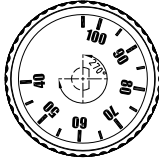
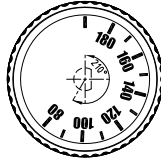
## Knob printings

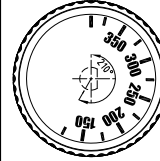
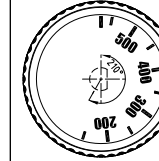
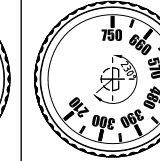
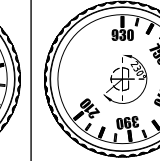
°C Printing							
-35+35°C	4-40°C	30-90°C	30-110°C	50-200°C	50-300°C	100-400°C	100-500°C
							
°F Printing							
-30+95°F	40-105°F	85-195°F	90-230°F	120-390°F	120-570°F	210-750°F	210-930°F
							

Because of permanent improvement of our products, drawings, descriptions, features used on these data sheets are for guidance only and can be modified without prior advice



Because of permanent improvement of our products, drawings, descriptions, features used on these data sheets are for guidance only and can be modified without prior advice

# Combination of adjustable set point thermostat and manual reset high limit, IP54 commercial housing, **Type Y08** With immersion heater mounting bracket

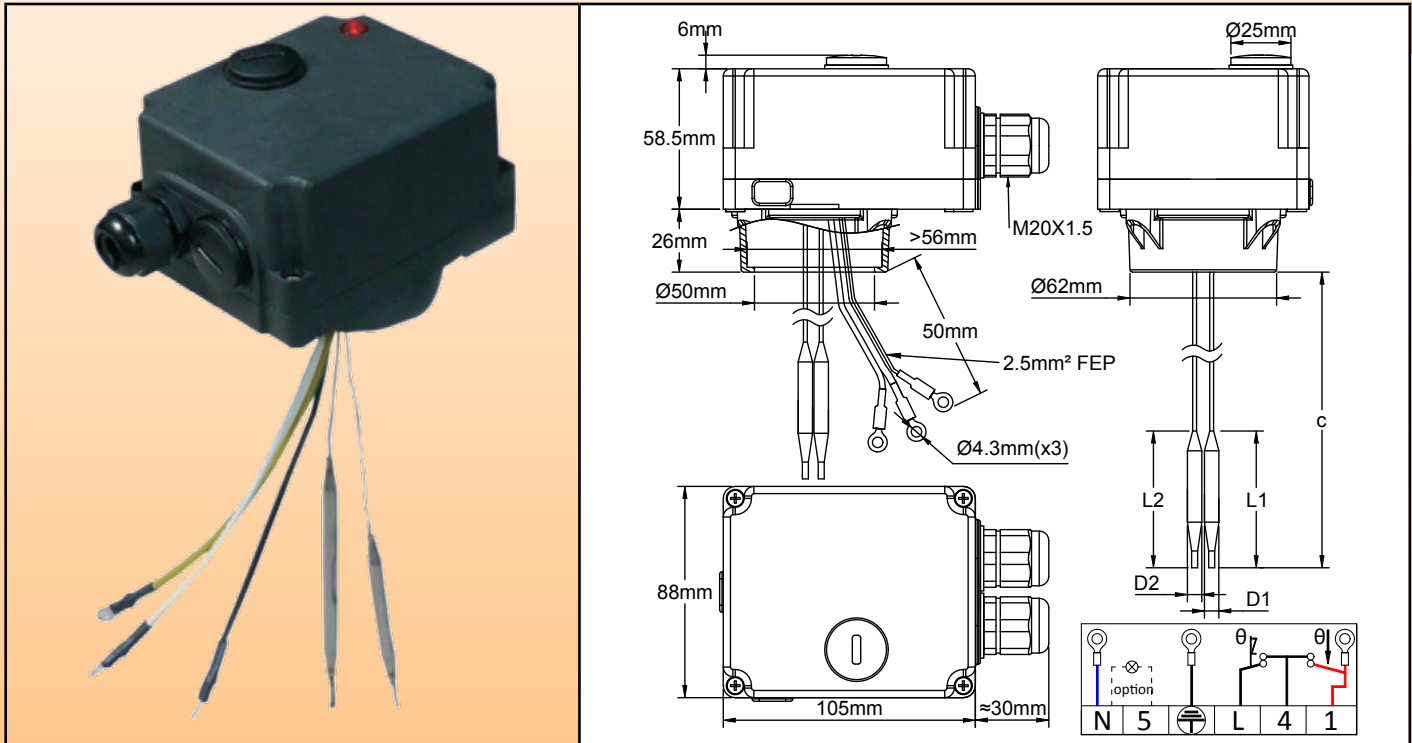

## Main applications:

Control sub-assembly designed to be fitted directly on standard immersion heaters. Power up to 3500W, 230V, single phase.

**Housing:** IP54, 105 × 88 × 84.5mm, (Cap, accessories and cable gland not included), black PC-ABS, UL94V0. High impact and UV resistance.

Product including an adjustable temperature control thermostat and a fixed setting high limit manual reset thermostat. Manual reset has access from outside, by removing a cap.

**Electrical input:** one M20 cable gland.

**Temperature Adjustment:** Inside, with °C printed knob. (°F printed knobs available in option)

**Sensing elements:** Liquid filled bulbs, dia. 6mm, with output on backside, for mounting inside immersion heater pockets

**Adjustment ranges:** 0-60°C (32-140°F); 30-90°C (85-195°F); 30-110°C (90-230°F)

**Sensing element output lengths (C):** 500mm (standard), other lengths from 150mm to 800mm available on request

### Electrical connections:

- Power supply (Neutral, Line, Ground), on 6mm<sup>2</sup> screw terminals.
- Immersion heater: 3 wires, FEP 180°C insulated, 2.5mm<sup>2</sup>, equipped with ring terminals, length 50mm on the immersion heater connection side, for direct connection on heating element M4 terminals. (Neutral wire is blue color)
- Pilot light (Option): can be connected by a strap on power supply, or on control thermostat output, or on safety thermostat output.

**Mounting:** by the backside extension, on the 50mm diameter hole, that can be used for immersion heaters with 1"1/2 thread or M45 thread, mounted by nut or by dia 56mm rotation ring

**Control thermostat contact:** Open on temperature rise contact (C-1) 16A (2.6) 250VAC

- Electrical life >100,000 cycles.

**Manual reset thermostat contact:** Fail safe, open by temperature rise; 16A (2.6) 250V alt.

Control thermostat and manual reset thermostat contacts are in serial on the Line supply of immersion heater.

### Options:

- Pilot light (230V)
- Lifiable adjustable high end adjustment on control thermostat.
- Outside access to the control thermostat adjustment (By removing a 40mm dia. cap)
- Thermal cut out for incorporation inside immersion heater pocket.

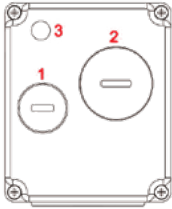
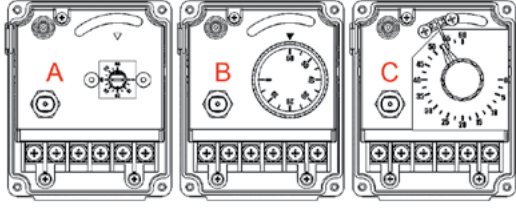

Cover options	Set point adjustment options
 <p>1: Manual reset cap (Standard) 2: Outside adjustment cap, dia 40mm (Option) 3: Pilot light (Option)</p>	 <p>A: Mini dial adjustment (Option to be selected for outside adjustment with cap 2). B: Soft-grip knob adjustment, (Standard). C: Liftable adjustable high limit (Option)</p>

### Main references (with C= 200mm)

Temperature ranges °C (°F)	Manual reset calibration °C (°F)	Cap access manual reset	Cap access manual reset, liftable adjustable high stop	Cap access manual reset, liftable adjustable high stop, power supply "on" pilot (230V)	Differential °C (°F)	Max temperature on bulbs °C (°F)
0-60°C (32-140°F)	80°C (176°F)	Y08MS00060A20080	Y08ME00060A20080	Y08NE00060C20080	4±3 (7±5.5°F)	90 (195°F)
30-90°C (85-195°F)	110°C (230°F)	Y08MS30090A20110	Y08ME30090A20110	Y08NE30090C20110	4±3 (7±5.5°F)	120 (250°F)
30-110°C (90-230°F)	130°C (266°F)	Y08MS30110A20130	Y08ME30110A20130	Y08NE30110C20130	5±3 (9±7°F)	150 (300°F)

Other temperature ranges on request. Versions with °F printed knobs: replace S by T or E by G in the reference

### Knob and dial printings

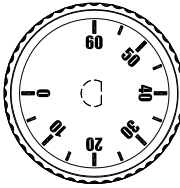
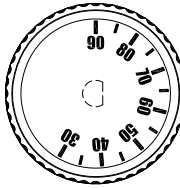
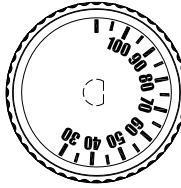
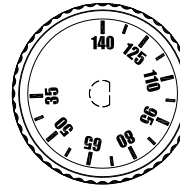
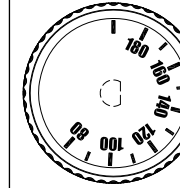
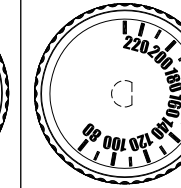
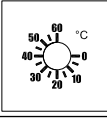
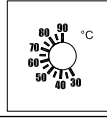
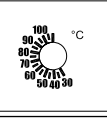
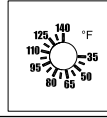
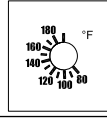
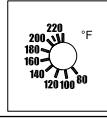
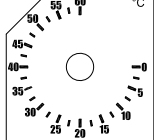
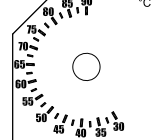
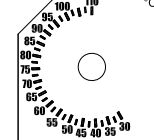
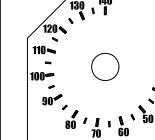
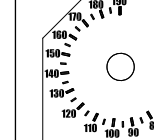
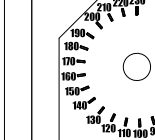
Type	°C Printing			°F Printing		
	0-60°C	30-90°C	30-110°C	32-140°F	85-195°F	90-230°F
Standard softgrip knob						
Miniature knob dial for outside adjustment						
Adjustable stop big dial						



# Combination of adjustable set point thermostat and manual reset high limit, IP54 commercial housing, capillary output, wall mounting,

## Type Y09

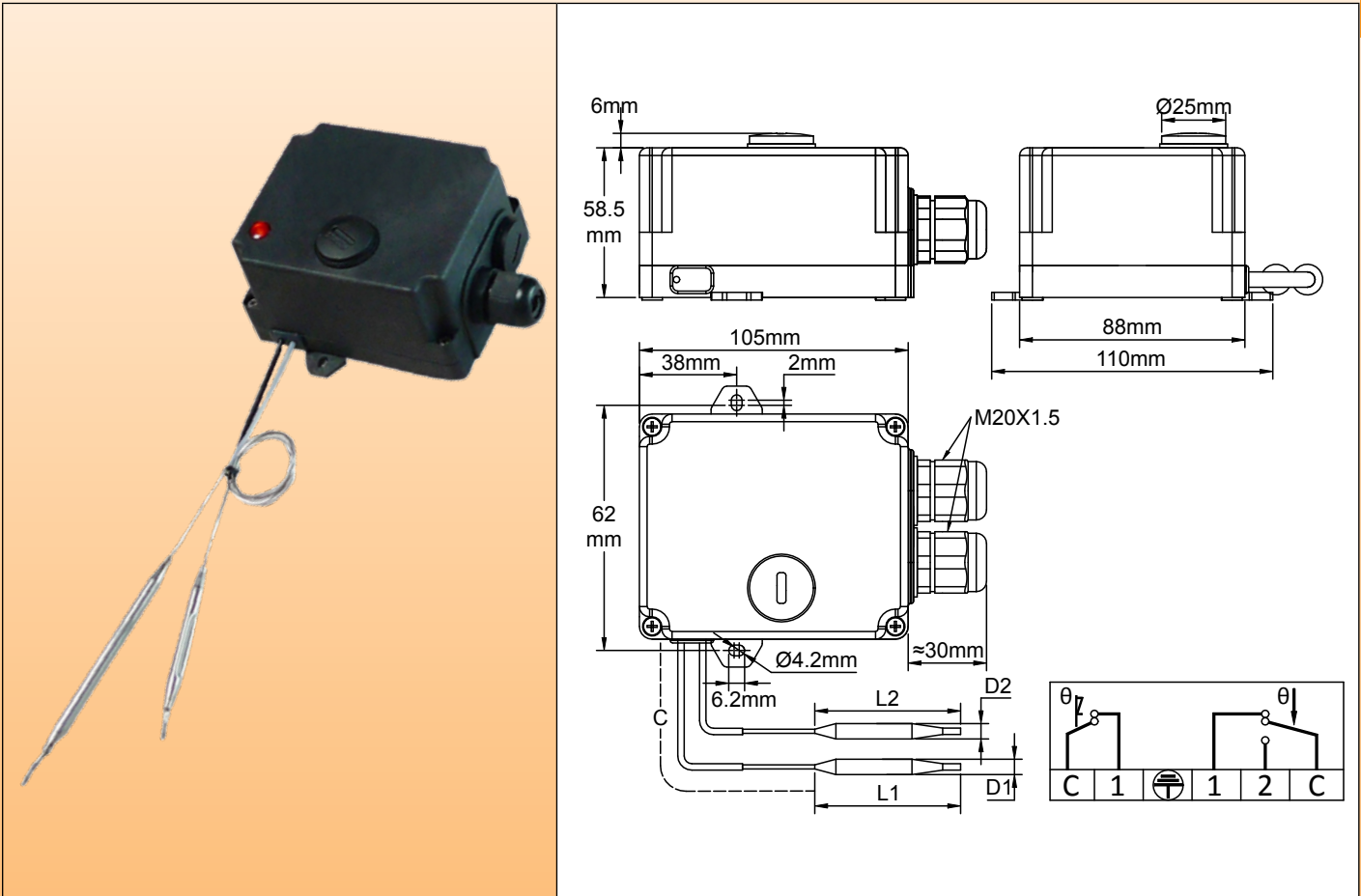

### Main applications

Control sub assembly designed to be used directly on standard immersion heaters, power up to 3500W, 230V, single phase.

**Housing:** IP54, 105 × 88 × 58.5mm, (Cap, accessories and cable gland not included), black PC-ABS, UL94V0. High impact and UV resistance.

Product including an adjustable temperature control thermostat and a fixed setting high limit manual reset thermostat. Manual reset has access from outside, by removing a cap.

**Electrical input:** Two M20 cable glands.

**Temperature Adjustment:** Inside, with °C printed knob. (°F printed knobs available in option)

**Sensing elements:** Liquid filled bulbs, dia. 6mm, with output on side of housing, for distance measurement.

**Adjustment ranges:** 0-60°C (32-140°F); 30-90°C (85-195°F); 30-110°C (90-230°F)

**Capillary lengths (C):** 900mm

**Electrical connections:** screw terminals

**Mounting:** With 2 wall mounting tabs, for M4 screws, 62mm distance

**Control thermostat contact:** SPDT

- Open on temperature rise contact (C-1) 16A (2.6) 250VAC
- Close on temperature rise contact (C-2) 6A (0.6) 250VAC
- Electrical life >100.000 cycles.

**Manual reset thermostat contact:** Fail safe, open by temperature rise; 16A (2.6) 250V alt.

**Options:**

- Power supply "energized" pilot light (Neutral is mandatory, and thermostat contact is open on rise only, not SPDT)
- Other pilot light wirings are possible on request.
- Lifiable adjustable high end adjustment on control thermostat.
  - Outside access to the control thermostat adjustment (By removing a 40mm dia cap)



# Combination of adjustable set point thermostat and manual reset high limit, IP54 commercial housing, capillary output, wall mounting

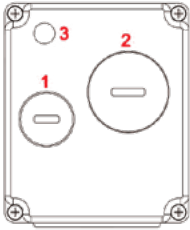
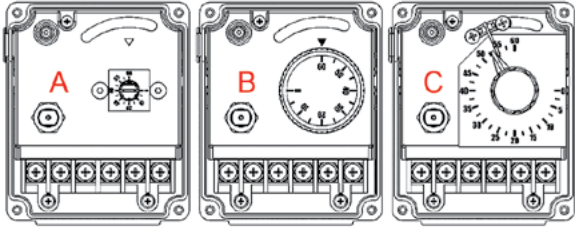

Cover options	Set point adjustment options
 <p>1: Manual reset cap. (Standard) 2: Outside adjustment cap, dia 40mm (Option) 3: Pilot light (Option)</p>	 <p>A: Mini dial adjustment (Option to be selected for outside adjustment with cap 2). B: Soft-grip knob adjustment, (Standard). C: Lifiable adjustable high limit (Option)</p>

## Main references

Temperature ranges °C (°F)	Manual reset calibration °C (°F)	Cap access manual reset	Cap access manual reset, liftable adjustable high stop	Cap access manual reset, liftable adjustable high stop, pilot light (230V)	Differential °C (°F)	Max temperature on bulbs °C (°F)
0-60°C (32-140°F)	80°C (176°F)	Y09MS00060A09080	Y09ME00060A09080	Y09NE00060C09080	4±3 (7±5.5°F)	90 (195°F)
30-90°C (85-195°F)	110°C (230°F)	Y09MS30090A09110	Y09ME30090A09110	Y09NE30090C09110	4±3 (7±5.5°F)	120 (250°F)
30-110°C (90-230°F)	130°C (266°F)	Y09MS30110A09130	Y09ME30110A09130	Y09NE30110C09130	5±3 (9±7°F)	150 (300°F)

\* Other temperature ranges on request.

Versions with °F printed knobs: replace S by T or E by G in the reference

## Knob and dial printings

Type	°C Printing			°F Printing		
	0-60°C	30-90°C	30-110°C	32-140°F	85-195°F	90-230°F
Standard softgrip knob						
Miniature knob dial for outside adjustment						
Adjustable stop big dial						

Because of permanent improvement of our products, drawings, descriptions, features used on these data sheets are for guidance only and can be modified without prior advice



# Bulb and capillary thermostats, with 2 built-in pilot lights



Because of permanent improvement of our products, drawings, descriptions, features used on these data sheets are for guidance only and can be modified without prior advice

Enclosure	Type	Operation	Contact	Measurement	Ranges °C	Models
IP55	Control	Mechanical	SPNC	Remote		<b>Y2D, Y2M</b>
Material						
PC - ABS						

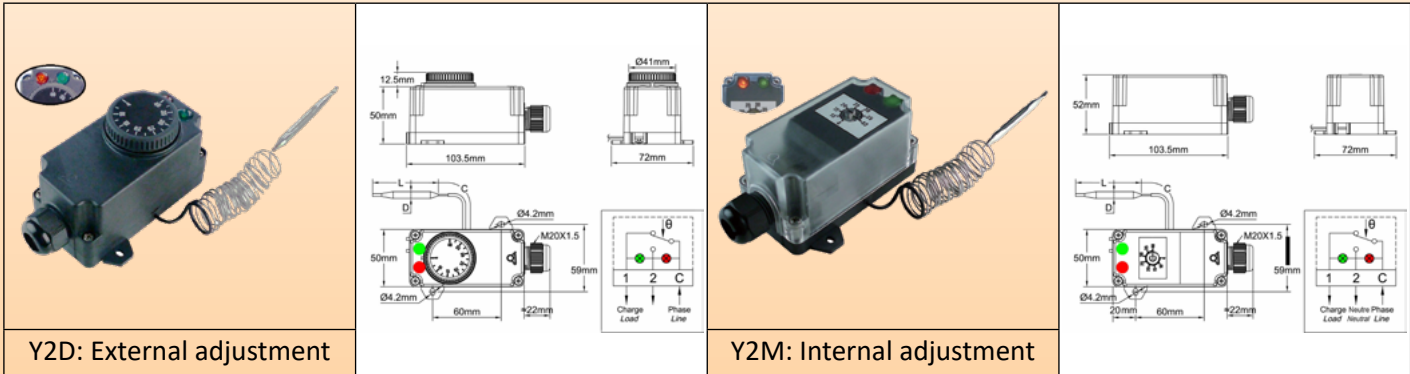

**Housing:** PC-ABS, fiberglass reinforced, UL94V0. High impact and UV resistance, with waterproof gasket on thermostat shaft for external adjustment types. Internal adjustment types have a PC transparent cover, to visualize the pilot lights and the set point adjustment.

**Cable input:** M20 cable gland, Black PA66, for cables from 6 to 12mm dia.

**Set point adjustment:** By °C printed knob for external adjustment models, by screw driver and printed dial on internal adjustment models. External adjustment types have an adjustable rotation limit system located inside the knob that allows reducing the set point adjustment span. °F values are available in option.

**Sensing element:** Liquid filled bulb, distance measurement with capillary..

**Temperature adjustment ranges:** -35+35°C (-30+95°F), 4-40°C (40-105°F), 30-90°C (85-195°F), 30-110°C (90-230°F), 50-200°C (120-390°F), 50-300°C (120-570°F), 100-400°C (210-750°F), 100-500°C (210-930°F).

**Capillary length:** 1.5 m

**Pilot lights:** Allow to visualize the power supply and thermostat contact position (230V Phase and Neutral power supply is mandatory for pilot lights)

**Electrical connections:** On screw terminals. (It is possible to connect 2 wires 1.5mm<sup>2</sup> on each terminal). **In option, an auxiliary connection block can be added, providing 3 neutral terminals.**

**Mounting:** Wall mounting, by two side lugs with holes for dia. 4mm screws, on a 59 × 60mm diagonal.

**Contact:** SPNC (open on temperature rise).

**Electrical rating, resistive loads:**

16A 250V, 50 ~60Hz: >100000 cycles,

20A 250V, 50 ~60Hz: ≥50000 cycles,

10A 400V, 50 ~60Hz: ≥50000 cycles.

**Electrical rating, inductive loads:**

6A 250V, 50 ~60Hz: >100000 cycles

**Minimum Storage temperature:** -35°C (-30°F)

**Maximum ambient temperature:** 60°C (140°F)

For more technical information ask 8G thermostat technical data sheet.

## Main references

Temperature ranges °C (°F)	External adjustment	Internal adjustment	Bulb diameter (D, mm)	Bulb length (L, mm)	Differential °C (°F)	Max temperature on bulb °C (°F)
-35+35°C (-30+95°F)	Y2D8GD035035AO6J	Y2M8GD035035AO6J	6	98	1.6±1 (2.9±2)	55 (130)
4-40°C (40-105°F)	Y2D8GD004040AO6J	Y2M8GD004040AO6J	6	140	1±0.5 (1.8±1)	60 (140)
30-90°C (85-195°F)	Y2D8GD030090AO6J	Y2M8GD030090AO6J	6	87	2.5±1 (4.5±1.8)	120 (250)
30-110°C (90-230°F)	Y2D8GD030110AO6J	Y2M8GD030110AO6J	6	93	2.5±1 (4.5±1.8)	150 (300)
50-200°C (120-390°F)	Y2D8GD050200AO6J	Y2M8GD050200AO6J	6	59	4±2 (7±3.6)	250 (480)
50-300°C (120-570°F)	Y2D8GD050300AO3J	Y2M8GD050300AO3J	3	145	10±5 (18±9)	350 (660)
100-400°C (210-750°F)	Y2D8GD0A0400AO3J	Y2M8GD0A0400AO3J	3	93	10±5 (18±9)	430 (800)
100-500°C (210-930°F)	Y2D8GD0A0500AO4J	Y2M8GD0A0500AO4J	4	235	10±5 (18±9)	550 (1000)

Version with auxiliary 3 way neutral terminal: replace D0 by D1 in the reference

°F printing: replace last character (J) by K

# Bulb and capillary thermostats, with 2 built-in pilot lights



## Knob printings

°C Printing							
-35+35°C	4-40°C	30-90°C	30-110°C	50-200°C	50-300°C	100-400°C	100-500°C
°F Printing							
-30+95°F	40-105°F	85-195°F	90-230°F	120-390°F	120-570°F	210-750°F	210-930°F

Because of permanent improvement of our products, drawings, descriptions, features used on these data sheets are for guidance only and can be modified without prior advice

# Bulb and capillary thermostats



Because of permanent improvement of our products, drawings, descriptions, features used on these data sheets are for guidance only and can be modified without prior advice

Enclosure	Type	Operation	Contact	Measurement	Ranges °C	Models
IP65, IK10	Control	Mechanical	SPDT	Remote		<b>Y1I8G, Y1G8G</b>
Material						
Aluminum						

<p>Y1I8G: External adjustment (With pilot light)</p>		<p>Y1G8G: Internal adjustment (Without pilot light)</p>	
--	--	---	--

## Applications

Remote control in usual industrial applications and environments, not hazardous areas.  
Internal adjustment is convenient for products that must not be frequently adjusted.

**Housing:** Aluminum, IP65, IK10. Mounted on a SUS304 stainless steel wall mounting plate which keeps temperature sensing element away from the wall. Grey RAL7032 epoxy painting. Stainless steel captive cover screws. Captive aluminum lid.

**Set point adjustment ranges:** -35+35°C (-30+95°F); -10+40°C (15-105°F); 4-40°C (40-105°F); 0-60°C (32-140°F); 0-90°C (32-195°F); 30-90°C (85-195°F); 30-110°C (85-230°F); 50-200°C (120-390°F); 50-300°C (120-570°F); 100-400°C (210-750°F); 100-500°C (210-930°F)

**Set point adjustment:** By °C printed knob. All types have an adjustable rotation limit system located inside the knob that allows reducing the set point adjustment span. Types with external adjustment have a transparent window. This device allows seeing the pilot light and the knob position. °F values are available as an option.

**Action:** Temperature control.

**Sensing element:** Liquid expansion bulb and capillary. The capillary is protected by a stainless steel corrugated pipe terminated by a silicone tip. A plastic cap plug provided as standard accessory allows locking the flexible metal conduit inside a pocket (See pockets in the accessories section).

**Electrical connections:** Inside, on screw terminal connection block

**Earthing:** Internal and external screw terminal.

**Pilot light:** Allow to visualize thermostat contact output position. Standard for all models with transparent window. Non Standard and on special request only for models with plain aluminum cover.

**Cable input and output:** Two M20 cable gland, Black PA66.

**Mounting:** Wall mounting, by 4 holes for screws dia. 4 to 5mm, 94 × 92mm distance

**Identification:** Metallic identification label, riveted.

**Contact:** SPDT

**Electrical rating, resistive loads:**

- Open on temperature rise contact (C-1)

16A 250V, 50 ~60Hz: >100000 cycles,

20A 250V, 50 ~60Hz: ≥50000 cycles,

10A 400V, 50 ~60Hz: ≥50000 cycles.

- Close on temperature rise contact (C-2): 6A 250V 50 ~60Hz: >100000 cycles

**Electrical rating, inductive loads:**

- Open on temperature rise contact (C-1): 6A 250V, 50 ~60Hz: >100000 cycles

- Close on temperature rise contact (C-2): 0.6A 250V 50 ~60Hz: >100000 cycles

**Minimum storage temperature:** -35°C (-30°F)

**Maximum ambient temperature:** 60°C (140°F)

For more technical information ask 8G thermostat technical data sheet.

# Bulb and capillary thermostats



## Main references

Temperature range °C (°F)	Reference with external adjustment	Reference with internal adjustment	Capillary length (C, mm)	Bulb diameter (D, mm)	Bulb length (L, mm)	Differential °C (°F)	Max temperature on bulb °C (°F)
-35+35°C (-30+95°F)	Y1I8G5035AO6000J	Y1G8G5035AO6000J	1500	6	120±5	1.6±1°C (2.9±2°F)	60°C (140°F)
-10+40°C (15-105°F)	Y1I8G0040AO6000J	Y1G8G0040AO6000J	1500	6	107±5	1.5±1°C (2.7±2°F)	70°C (158°F)
4-40°C (40-105°F)	Y1I8G4040AO6000J	Y1G8G4040AO6000J	1500	6	120±5	1±0.5°C (1.8±1°F)	70°C (158°F)
0-60°C (32-140°F)	Y1I8G0060AO6000J	Y1G8G0060AO6000J	1500	6	86±5	2.5±1°C (4.5±1.8°F)	80°C (176°F)
0-90°C (32-195°F)	Y1I8G0090AO6000J	Y1G8G0090AO6000J	1500	6	98±5	2.5±1°C (4.5±1.8°F)	120°C (250°F)
30-90°C (85-195°F)	Y1I8G3090AO6000J	Y1G8G3090AO6000J	1500	6	98±5	2.5±1°C (4.5±1.8°F)	120°C (250°F)
30-110°C (85-230°F)	Y1I8G3110AO6000J	Y1G8G3110AO6000J	1500	6	86±5	2.5±1°C (4.5±1.8°F)	140°C (284°F)
50-200°C (120-390°F)	Y1I8G5200AO6000J	Y1G8G5200AO6000J	1500	6	65±5	4±2°C (7±3.6°F)	230°C (446°F)
50-300°C (120-570°F)	Y1I8G5300AO3000J	Y1G8G5300AO3000J	1500	3	145±5	10°C±2°C (18±3.6°F)	330°C (626°F)
100-400°C (210-750°F)	Y1I8GA400AO3000J	Y1G8GA400AO3000J	1500	3	93±5	10°C±2°C (18±3.6°F)	430°C (800°F)
100-500°C (210-930°F)	Y1I8GA500AN4000J	Y1G8GA500AN4000J	1400	4	235±5	10°C±2°C (18±3.6°F)	550°C (1000°F)

\* °F printing: replace last character (J) by K

## Knob printings

°C Printing					
0-10°C	-35+35°C	-10+40°C	4-40°C	0-60°C	0-90°C
30-90°C	30-110°C	50-200°C	50-300°C	100-400°C	100-500°C
°F Printing					
32-50°F	-30+90°F	15-105°F	40-105°F	30-140°F	30-195°F
85-195°F	85-230°F	120-390°F	120-570°F	210-750°F	210-930°F

Because of permanent improvement of our products, drawings, descriptions, features used on these data sheets are for guidance only and can be modified without prior advice



# 3 Pole bulb and capillary thermostats



Because of permanent improvement of our products, drawings, descriptions, features used on these data sheets are for guidance only and can be modified without prior advice

Enclosure	Type	Operation	Contact	Measurement	Ranges °C	Models
IP65, IK10	Control	Mechanical	3PNC	Remote		<b>Y1I8C, Y1G8C</b>
Material						
Aluminum						

<p><b>Y1I8C: External adjustment</b></p>		<p><b>Y1G8C: Internal adjustment</b></p>	
--	--	--	--

## Applications

Remote control in usual industrial application and environment, not hazardous areas, when it is requested to control a 3 phases heating circuit.  
Internal adjustment is convenient for products that must not be frequently adjusted.

**Housing:** Aluminum, IP65, IK10. Mounted on a SUS304 stainless steel wall mounting plate which keeps temperature sensing element away from the wall. Grey RAL7032 epoxy painting. Stainless steel captive cover screws. Captive aluminum lid.

**Set point adjustment ranges:** -35+35°C (-30+95°F); -10+40°C (15-105°F); 4-40°C (40-105°F); 0-60°C (32-140°F); 0-90°C (32-195°F); 30-90°C (85-195°F); 30-110°C (85-230°F); 50-200°C (120-390°F); 50-300°C (120-570°F); 100-400°C (210-750°F).

**Set point adjustment:** By °C printed knob. All types have an adjustable rotation limit system located inside the knob that allows reducing the set point adjustment span. Types with external adjustment have a transparent window. This device allows seeing the pilot light and the knob position. °F values are available in option

**Action:** Temperature control.

**Sensing element:** Liquid expansion bulb and capillary. The capillary is protected by a stainless steel corrugated pipe terminated by a silicone tip. A plastic cap plug provided as standard accessory allows locking the flexible metal conduit inside a pocket (See pockets in the accessories section).

**Electrical connections:** Inside, on screw terminal connection block

**Earthing:** External screw terminal.

**Cable input and output:** Two M20 cable gland, Black PA66.

**Mounting:** Wall mounting, by 4 holes for screws dia. 4 to 5mm, 94 × 92mm distance

**Identification:** Metallic identification label, riveted.

**Contact:** 3PST

**Electrical rating, resistive loads:**

16A 250V, 50 ~60Hz: >100000 cycles,

20A 250V, 50 ~60Hz: ≥50000 cycles,

10A 400V, 50 ~60Hz: ≥50000 cycles.

**Minimum Storage temperature:** -35°C (-30°F)

**Maximum ambient temperature:** 60°C (140°F)

For more technical information ask 8C thermostat technical data sheet.

## Main references

Temperature range °C (°F)	Reference with external adjustment	Reference with internal adjustment	Capillary length (C, mm)	Bulb diameter (D, mm)	Bulb length (L, mm)	Differential °C (°F)	Max temperature on bulb °C (°F)
-35+35°C (-30+95°F)	Y1I8C5035AO6000J	Y1G8C5035AO6000J	1500	6	120±5	1.6±1°C (2.9±2°F)	60°C (140°F)
-10+40°C (15-105°F)	Y1I8C0040AO6000J	Y1G8C0040AO6000J	1500	6	107±5	1.5±1°C (2.7±2°F)	70°C (158°F)
4-40°C (40-105°F)	Y1I8C4040AO6000J	Y1G8C4040AO6000J	1500	6	120±5	1±0.5°C (1.8±1°F)	70°C (158°F)
0-60°C (32-140°F)	Y1I8C0060AO6000J	Y1G8C0060AO6000J	1500	6	86±5	2.5±1°C (4.5±1.8°F)	80°C (176°F)
0-90°C (32-195°F)	Y1I8C0090AO6000J	Y1G8C0090AO6000J	1500	6	98±5	2.5±1°C (4.5±1.8°F)	120°C (250°F)
30-90°C (85-195°F)	Y1I8C3090AO6000J	Y1G8C3090AO6000J	1500	6	98±5	2.5±1°C (4.5±1.8°F)	120°C (250°F)

# 3 Pole bulb and capillary thermostats



Temperature range °C (°F)	Reference with external adjustment	Reference with internal adjustment	Capillary length (C, mm)	Bulb diameter (D, mm)	Bulb length (L, mm)	Differential °C (°F)	Max temperature on bulb °C (°F)
30-110°C (85-230°F)	Y18C3110AO6000J	Y1G8C3110AO6000J	1500	6	86±5	2.5±1°C (4.5±1.8°F)	140°C (284°F)
50-200°C (120-390°F)	Y18C5200AO6000J	Y1G8C5200AO6000J	1500	6	65±5	4±2°C (7±3.6°F)	230°C (446°F)
50-300°C (120-570°F)	Y18C5300AO3000J	Y1G8C5300AO3000J	1500	3	145±5	10°C±2°C (18±3.6°F)	330°C (626°F)
100-400°C (210-750°F)	Y18CA400AO3000J	Y1G8CA400AO3000J	1500	3	93±5	10°C±2°C (18±3.6°F)	430°C (800°F)

\*F printing: replace last character (J) by K

## Knob printings

°C Printing				
-35+35°C	-10+40°C	4-40°C	0-60°C	0-90°C
30-90°C	30-110°C	50-200°C	50-300°C	100-400°C
°F Printing				
-30+95°F	15-105°F	40-105°F	30-140°F	30-195°F
85-195°F	85-230°F	120-390°F	120-570°F	210-750°F

Because of permanent improvement of our products, drawings, descriptions, features used on these data sheets are for guidance only and can be modified without prior advice



# Immersion heater thermostats



Because of permanent improvement of our products, drawings, descriptions, features used on these data sheets are for guidance only and can be modified without prior advice

Enclosure	Type	Operation	Contact	Measurement	Ranges °C	Models
IP66, IK10	Control	Mechanical	SPDT	Immersion heater		<b>YF8GNC</b>
Material PA66 + PC						

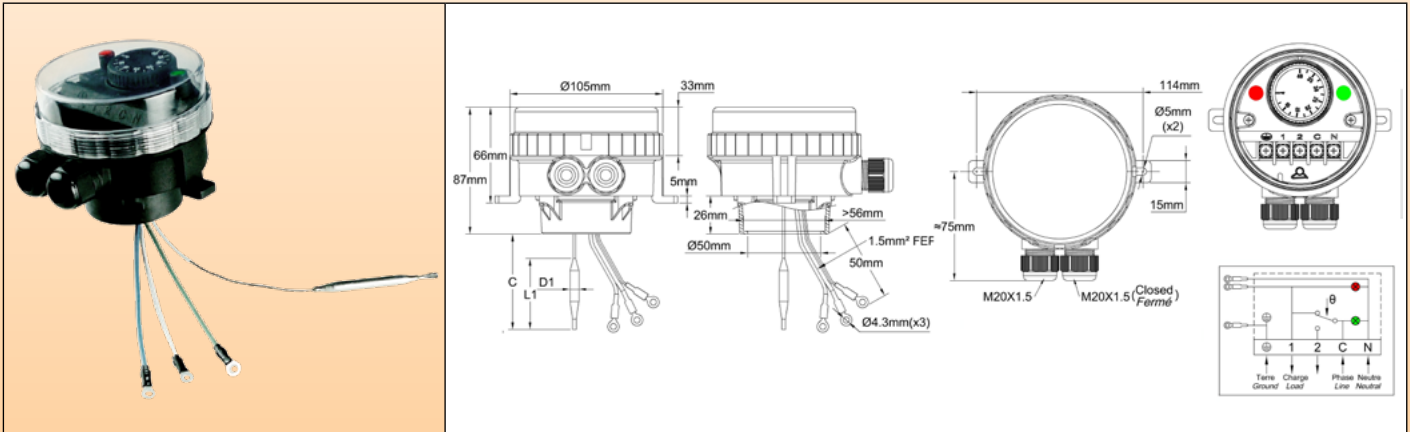

## Applications

- Equipment requesting a very strong resistance to water ingress. The transparent cover allows to visualize the set point and the 2 pilot lights

Fully wired sub assembly for use on immersion heater elements, 1"1/2 or M45x2 with double thread or rotation ring. Applications in usual industrial applications and environments, non-hazardous areas.

**Housing:** Protection class IP 66 upon EN 60529 (waterproof spray water under high pressure and sea splashes, totally dust tight). Body in black PA66, fiber glass reinforced. The transparent polycarbonate cover can be unscrewed by hand, but it is also possible to use a hook spanner. A removable adapter is screwed at the bottom of the enclosure. It fits the usual immersion heater fittings. Mechanical impact resistance: IK10. High UV resistance.

**Set point adjustment:** By °C printed knob. All types have an adjustable rotation limit system located inside the knob that allows reducing the set point adjustment span. °F printed knobs available as an option.

**Action:** Temperature control. On-Off action

**Sensing element:** Liquid expansion bulb and capillary. The bulb and the capillary go out by the bottom of the enclosure to fit in the heater pocket.

**Pilot lights:** One pilot light visualizes the thermostat contact output position. The other visualizes the power supply input. Phase and line electrical supply is mandatory for these pilot lights.

**Set point adjustment ranges:** 0-60°C (32-140°F); 0-90°C (32-195°F); 30-90°C (85-195°F); 30-110°C (85-230°F).

**Cable input and output:** Two M20 cable glands, built-in black PA66. One of them is closed.

**Electrical connections:** Inside, on screw terminal connection block. It is possible to connect 2 wires 1.5mm<sup>2</sup> on each terminal.

**Earthing:** Internal screw terminal and wire with round hole terminal for the immersion heater.

**Mounting:** By the immersion heater thread or by 2 legs with holes for screws dia. 4 to 5mm, 114mm distance

**Identification:** Identification label on backside

**Contact:** SPDT

**Electrical rating, resistive loads:**

- Open on temperature rise contact (C-1)

16A 250V, 50 ~60Hz: >100000 cycles,

20A 250V, 50 ~60Hz: ≥50000 cycles,

10A 400V, 50 ~60Hz: ≥50000 cycles.

- Close on temperature rise contact (C-2): 6A 250V 50 ~60Hz: >100000 cycles

**Electrical rating, inductive loads:**

- Open on temperature rise contact (C-1): 2.6A 250V, 50 ~60Hz: >100000 cycles

- Close on temperature rise contact (C-2): 0.6A 250V 50 ~60Hz: >100000 cycles.

**Minimum storage temperature:** -35°C (-30°F)

**Maximum ambient temperature:** 60°C (140°F)

For more technical information ask 8G thermostat technical data sheet.

# Immersion heater thermostats



## Main references

Temperature range	References	Capillary length (C, mm)	Bulb diameter (D1, mm)	Bulb length (L1, mm)	Differential °C (°F)	Max temperature on bulb °C (°F)
0-60°C (32-140°F)	YF8GNC00060026ZJ	200	6	86±5	2.5±1°C (4.5±1.8°F)	80°C (176°F)
0-60°C (32-140°F)	YF8GNC00060036ZJ	300	6	86±5	2.5±1°C (4.5±1.8°F)	80°C (176°F)
0-60°C (32-140°F)	YF8GNC00060046ZJ	400	6	86±5	2.5±1°C (4.5±1.8°F)	80°C (176°F)
0-60°C (32-140°F)	YF8GNC00060056ZJ	500	6	86±5	2.5±1°C (4.5±1.8°F)	80°C (176°F)
0-90°C (32-195°F)	YF8GNC00090026ZJ	200	6	98±5	2.5±1°C (4.5±1.8°F)	120°C (250°F)
0-90°C (32-195°F)	YF8GNC00090036ZJ	300	6	98±5	2.5±1°C (4.5±1.8°F)	120°C (250°F)
0-90°C (32-195°F)	YF8GNC00090046ZJ	400	6	98±5	2.5±1°C (4.5±1.8°F)	120°C (250°F)
0-90°C (32-195°F)	YF8GNC00090056ZJ	500	6	98±5	2.5±1°C (4.5±1.8°F)	120°C (250°F)
30-90°C (85-195°F)	YF8GNC30090026ZJ	200	6	98±5	2.5±1°C (4.5±1.8°F)	120°C (250°F)
30-90°C (85-195°F)	YF8GNC30090036ZJ	300	6	98±5	2.5±1°C (4.5±1.8°F)	120°C (250°F)
30-90°C (85-195°F)	YF8GNC30090046ZJ	400	6	98±5	2.5±1°C (4.5±1.8°F)	120°C (250°F)
30-90°C (85-195°F)	YF8GNC30090056ZJ	500	6	98±5	2.5±1°C (4.5±1.8°F)	120°C (250°F)
30-110°C (85-230°F)	YF8GNC30110026ZJ	200	6	86±5	2.5±1°C (4.5±1.8°F)	140°C (284°F)
30-110°C (85-230°F)	YF8GNC30110036ZJ	300	6	86±5	2.5±1°C (4.5±1.8°F)	140°C (284°F)
30-110°C (85-230°F)	YF8GNC30110046ZJ	400	6	86±5	2.5±1°C (4.5±1.8°F)	140°C (284°F)
30-110°C (85-230°F)	YF8GNC30110056ZJ	500	6	86±5	2.5±1°C (4.5±1.8°F)	140°C (284°F)

°F printing: replace last character (J) by K

## Knob printings

°C Printing				°F Printing			
0-60°C	0-90°C	30-90°C	30-110°C	32-140°F	32-195°F	85-195°F	85-230°F

Because of permanent improvement of our products, drawings, descriptions, features used on these data sheets are for guidance only and can be modified without prior advice

# Bulb and capillary thermostats



Because of permanent improvement of our products, drawings, descriptions, features used on these data sheets are for guidance only and can be modified without prior advice

Enclosure	Type	Operation	Contact	Measurement	Ranges °C	Models
IP66, IK10	Control	Mechanical	SPDT	Remote		<b>YF9GNC</b>
Material PA66 + PC						

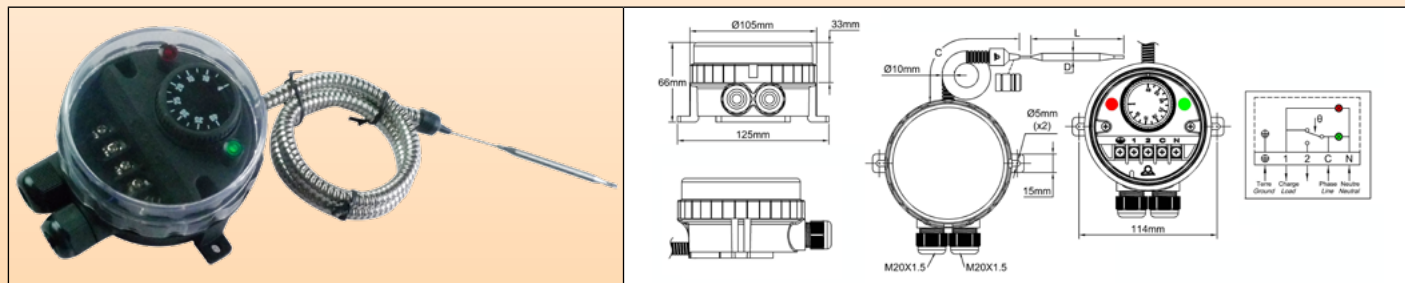

## Applications

- Equipment requesting a very strong resistance to water ingress. The transparent cover allows to visualize the set point and the 2 pilot lights

Remote control in usual industrial application and environment, not hazardous areas.

**Housing:** Protection class IP 66 upon EN 60529 (waterproof spray water under high pressure and sea splashes, totally dust tight). Body in black PA66, fiber glass reinforced. The transparent polycarbonate cover can be unscrewed by hand, but it is also possible to use a hook spanner. Mechanical impact resistance: IK10. High UV resistance.

**Set point adjustment:** By °C printed knob. All types have an adjustable rotation limit system located inside the knob that allows reducing the set point adjustment span. °F printed knobs available as an option.

**Action:** Temperature control. On-Off action.

**Sensing element:** Liquid expansion bulb and capillary. The capillary is protected by a stainless steel corrugated pipe terminated by a silicone tip. A plastic cap plug provided as standard accessory allows locking the flexible metal conduit inside a pocket (See pockets in the accessories section).

**Pilot lights:** One pilot light visualizes the thermostat contact output position. The other visualizes the power supply input. Phase and line electrical supply is mandatory for these pilot lights.

**Set point adjustment ranges:** -35+35°C (-30+95°F); -10+40°C (15-105°F); 4-40°C (40-105°F); 0-60°C (32-140°F); 0-90°C (32-195°F); 30-90°C (85-195°F); 30-110°C (85-230°F); 50-200°C (120-390°F); 50-300°C (120-570°F); 100-400°C (210-750°F); 100-500°C (210-930°F)

**Cable input and output:** Two M20 cable glands, built-in black PA66.

**Electrical connections:** Inside, on screw terminal connection block. It is possible to connect 2 wires 1.5mm<sup>2</sup> on each terminal.

**Earthing:** Internal screw terminal.

**Mounting:** Wall mounting, by 2 legs with holes for screws dia. 4 to 5mm, 114mm distance

**Identification:** Identification label on backside

**Contact:** SPDT

**Electrical rating, resistive loads:**

- Open on temperature rise contact (C-1)

16A 250V, 50 ~60Hz: >100000 cycles,

20A 250V, 50 ~60Hz: ≥50000 cycles,

10A 400V, 50 ~60Hz: ≥50000 cycles.

- Close on temperature rise contact (C-2): 6A 250V 50 ~60Hz: >100000 cycles

**Electrical rating, inductive loads:**

- Open on temperature rise contact (C-1): 2.6A 250V, 50 ~60Hz: >100000 cycles

- Close on temperature rise contact (C-2): 0.6A 250V 50 ~60Hz: >100000 cycles.

**Minimum storage temperature:** -35°C (-30°F)

**Maximum ambient temperature:** 60°C (140°F)

For more technical information ask 8G thermostat technical data sheet.

## Main references

Temperature range °C (°F)	References	Capillary length (C, mm)	Bulb diameter (D, mm)	Bulb length (E, mm)	Differential °C (°F)	Max temperature on bulb °C (°F)
-35+35°C (-30+95°F)	YF9GNC35035156ZJ	1500	6	120±5	1.6±1°C (2.9±2°F)	60°C (140°F)
-10+40°C (15-105°F)	YF9GNC10040156ZJ	1500	6	107±5	1.5±1°C (2.7±2°F)	70°C (158°F)
4-40°C (40-105°F)	YF9GNC04040156ZJ	1500	6	120±5	1±0.5°C (1.8±1°F)	70°C (158°F)

# Bulb and capillary thermostats



Temperature range °C (°F)	References	Capillary length (C, mm)	Bulb diameter (D, mm)	Bulb length (E, mm)	Differential °C (°F)	Max temperature on bulb °C (°F)
0-60°C (32-140°F)	YF9GNC00060156ZJ	1500	6	86±5	2.5±1°C (4.5±1.8°F)	80°C (176°F)
0-90°C (32-195°F)	YF9GNC00090156ZJ	1500	6	98±5	2.5±1°C (4.5±1.8°F)	120°C (250°F)
30-90°C (85-195°F)	YF9GNC30090156ZJ	1500	6	98±5	2.5±1°C (4.5±1.8°F)	120°C (250°F)
30-110°C (85-230°F)	YF9GNC30110156ZJ	1500	6	86±5	2.5±1°C (4.5±1.8°F)	140°C (284°F)
50-200°C (120-390°F)	YF9GNC50200156ZJ	1500	6	65±5	4±2°C (7±3.6°F)	230°C (446°F)
50-300°C (120-570°F)	YF9GNC50300153ZJ	1500	3	145±5	10°C±2°C (18±3.6°F)	330°C (626°F)
100-400°C (210-750°F)	YF9GNCA0400153ZJ	1500	3	93±5	10°C±2°C (18±3.6°F)	430°C (800°F)
100-500°C (210-930°F)	YF9GNCA0500144ZJ	1400	4	235±5	10°C±2°C (18±3.6°F)	550°C (1000°F)

\*F printing: replace last character (J) by K

## Knob printings

°C Printing					
0-10°C	-35+35°C	-10+40°C	4-40°C	0-60°C	0-90°C
30-90°C	30-110°C	50-200°C	50-300°C	100-400°C	100-500°C
°F Printing					
32-50°F	-30+90°F	15-105°F	40-105°F	30-140°F	30-195°F
85-195°F	85-230°F	120-390°F	120-570°F	210-750°F	210-930°F

Because of permanent improvement of our products, drawings, descriptions, features used on these data sheets are for guidance only and can be modified without prior advice



Because of permanent improvement of our products, drawings, descriptions, features used on these data sheets are for guidance only and can be modified without prior advice

# Rod mechanical thermostat



Because of permanent improvement of our products, drawings, descriptions, features used on these data sheets are for guidance only and can be modified without prior advice



# Rod thermostats



Because of permanent improvement of our products, drawings, descriptions, features used on these data sheets are for guidance only and can be modified without prior advice

Enclosure	Type	Operation	Contact	Measurement	Ranges °C	Models
IP44	Control	Mechanical	SPDT	Rod		<b>Y048</b> <b>Y049</b>
Material						
PC- ABS						

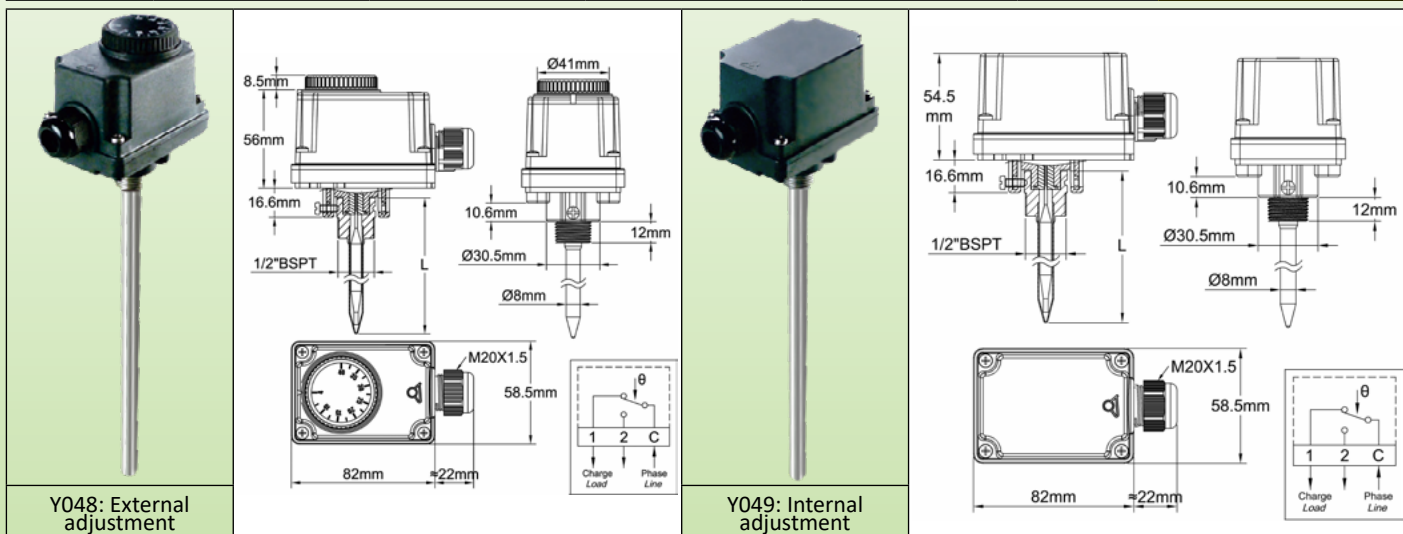

**Housing:** IP44, black PC-ABS, UL94V0. High impact and UV resistance. 2 removable wall mounting lugs.

**Cable input:** One M20 cable gland.

**Set point adjustment:** By °C printed knob for external adjustment models, by screw driver and printed dial on internal adjustment models. °F values available as an option.

**Sensing element:** Liquid filled bulb, located inside a backside mounted pocket in 304L stainless steel or nickel plated brass.

**Adjustment ranges:** -35+35°C (-30+95°F), 4-40°C (40-105°F), 30-90°C (85-195°F), 30-110°C (90-230°F)

**Rod length:** 90, 230, 300mm. Other length on request

**Electrical connections:** 3 screw terminal connection block

**Mounting:** by the 1/2" BSPT pocket fitting

**Contact:** SPDT

**Electrical rating, resistive loads:**

- Open on temperature rise contact (C-1)

16A 250V, 50 ~60Hz: >100000 cycles,

20A 250V, 50 ~60Hz: ≥50000 cycles,

10A 400V, 50 ~60Hz: ≥50000 cycles.

- Close on temperature rise contact (C-2): 6A 250V, 50 ~60Hz: >100000 cycles

**Electrical rating, inductive loads:**

- Open on temperature rise contact (C-1): 6A 250V, 50 ~60Hz: >100000 cycles

- Close on temperature rise contact (C-2): 0.6A 250V, 50 ~60Hz: >100000 cycles.

**Minimum storage temperature:** -35°C (-30°F)

**Maximum ambient temperature:** 60°C (140°F)

**Option:** Short plastic pocket for swimming pool applications

For more technical information see 8G thermostat technical data sheet.

## Main references with external\* adjustment and nickel plated brass pocket

Temperature ranges °C (°F)	References with rod length L=90 mm	References with rod length L=230 mm	References in °C with rod length L=300 mm	Differential °C (°F)	Max temperature on rod °C (°F)
-35+35°C (-30+95°F)		Y048GB-35035N23J	Y048GB-35035N30J	1.6±1°C (2.9±2°F)	55 (130)
4-40°C (40-105°F)		Y048GB004040N23J	Y048GB004040N30J	1±0.5°C (1.8±1°F)	60 (140)
30-90°C (85-195°F)	Y048GB030090N09J	Y048GB030090N23J	Y048GB030090N30J	2.5±1°C (4.5±1.8°F)	120 (250)
30-110°C (90-230°F)	Y048GB030110N09J	Y048GB030110N23J	Y048GB030110N30J	2.5±1°C (4.5±1.8°F)	150 (300)

# Rod thermostats



## Main references with external\* adjustment and AISI 304 pocket

Temperature ranges °C (°F)	References with rod length L=90 mm	References with rod length L=230 mm	References in °C with rod length L=300 mm	Differential °C (°F)	Max temperature on rod
-35+35°C (-30+95°F)		Y048GB-35035I23J	Y048GB-35035I30J	1.6±1°C (2.9±2°F)	55 (130)
4-40°C (40-105°F)		Y048GB004040I23J	Y048GB004040I30J	1±0.5°C (1.8±1°F)	60 (140)
30-90°C (85-195°F)	Y048GB030090I09J	Y048GB030090I23J	Y048GB030090I30J	2.5±1°C (4.5±1.8°F)	120 (250)
30-110°C (90-230°F)	Y048GB030110I09J	Y048GB030110I23J	Y048GB030110I30J	2.5±1°C (4.5±1.8°F)	150 (300)

\* Internal adjustment: replace Y048 by Y049

°F printing: replace last character (J) by K

## Knob printings

°C Printing				°F Printing			
-35+35°C	4-40°C	30-90°C	30-110°C	-30+90°F	40-105°F	85-195°F	85-230°F

Because of permanent improvement of our products, drawings, descriptions, features used on these data sheets are for guidance only and can be modified without prior advice

# Rod thermostats, with built-in pilot light and 2 or 3 M20 cable glands, stainless steel or nickel plated brass pocket



Because of permanent improvement of our products, drawings, descriptions, features used on these data sheets are for guidance only and can be modified without prior advice

Enclosure	Type	Operation	Contact	Measurement	Ranges °C	Models
IP55	Control	Mechanical	SPNC	Rod		<b>YOB8</b> <b>YOB9</b>
Material						
PC- ABS						

YOB9: Internal adjustment		YOB8: External adjustment	

## Applications

Ambient temperature control in professional premises where good protection against liquid splashes or dust is requested.

Output with 2 or 3 cable glands, allowing direct connection of heat tracing cables for freeze protection.

**Housing:** Reduced height, IP44, black PC-ABS fiberglass reinforced, UL94V0. High impact and UV resistance. 2 removable wall mounting lugs.

**Cable input:** M20 cable glands. Delivered with 2 or 3 cable glands. **Special cable glands for oblong or flat heat tracing cables are available on request.** Positioning the cable glands allows variations in the mounting position

**Set point adjustment:** By °C printed knob for external adjustment models, by screw driver and printed dial on internal adjustment models. °F values available in option

**Sensing element:** Liquid filled "pigtail" bulb, mounted on the side of plastic housing

**Adjustment ranges:** 4-40°C (40-105°F).

**Electrical connections:** On screw terminals. (It is possible to connect 2 wires 1.5mm<sup>2</sup> on each terminal). **One main terminal and 3 auxiliary terminals are available for neutral connection. This allows, for example, connecting two heat trace heaters.**

**Mounting:** Wall mounting, by two side lugs with holes for dia. 4mm screws, 69 mm distance.

**Contact:** SPNC (open on temperature rise).

**Pilot light:** Neon, 230V, standard in red, parallel connection on the load

**Electrical rating, resistive loads:**

16A 250V, 50 ~60Hz: >100000 cycles,

20A 250V, 50 ~60Hz: ≥50000 cycles,

10A 400V, 50 ~60Hz: ≥50000 cycles.

**Electrical rating, inductive loads:**

6A 250V, 50 ~60Hz: >100000 cycles

**Minimum Storage temperature:** -35°C (-30°F)

**Maximum ambient temperature:** 60°C (140°F)

For more technical information see 8G thermostat technical data sheet

# Rod thermostats, with built-in pilot light and 2 or 3 M20 cable glands, stainless steel or nickel plated brass pocket



## Main references with nickel plated brass pocket and 3 cable glands\*

Temperature ranges °C (°F)	Adjustment	References in °C with rod length L=90 mm**	References in °C with rod length L=230 mm**	References in °C with rod length L=300 mm**	Differential °C (°F)	Max temperature on rod
-35+35°C (-30+95°F)	External		YOB8LD135035N23J	YOB8LD135035N30J	3±2°C (5.5±4°F)	55°C (130°F)
4-40°C (40-105°F)	External		YOB8LD104040N23J	YOB8LD104040N30J	2.5±1.5°C (4.5±2.5°F)	60°C (140°F)
30-90°C (85-195°F)	External	YOB8LD130090N09J	YOB8LD130090N23J	YOB8LD130090N30J	4±3°C (7±5.5°F)	120°C (250°F)
30-110°C (90-230°F)	External	YOB8LD130110N09J	YOB8LD130110N23J	YOB8LD130110N30J	5±3°C (9±7°F)	150°C (300°F)
-35+35°C (-30+95°F)	Internal		YOB9LD135035N23J	YOB9LD135035N30J	3±2°C (5.5±4°F)	55°C (130°F)
4-40°C (40-105°F)	Internal		YOB9LD104040N23J	YOB9LD104040N30J	2.5±1.5°C (4.5±2.5°F)	60°C (140°F)
30-90°C (85-195°F)	Internal	YOB8LD130090N09J	YOB9LD130090N23J	YOB9LD130090N30J	4±3°C (7±5.5°F)	120°C (250°F)
30-110°C (90-230°F)	Internal	YOB8LD130110N09J	YOB9LD130110N23J	YOB9LD130110N30J	5±3°C (9±7°F)	150°C (300°F)

\* 2 cable gland version: replace LD by KD in the reference

AISI 304 pocket: replace N by I in the reference

\*\* °F printing: replace last character (J) by K

## Knob printings

°C Printing				°F Printing			
-35+35°C	4-40°C	30-90°C	30-110°C	-30+90°F	40-105°F	85-195°F	85-230°F

Because of permanent improvement of our products, drawings, descriptions, features used on these data sheets are for guidance only and can be modified without prior advice

Because of permanent improvement of our products, drawings, descriptions, features used on these data sheets are for guidance only and can be modified without prior advice

**Rod thermostat, 2 or 3 cable gland IP44 enclosure, for heat control, with built-in pilot light. Stainless steel or nickel plated brass pocket**



**Thermostat with IP44 extra flat plastic enclosure, 95 × 60 × 40mm, with pilot light. Rod temperature sensor. Stainless steel or Brass pocket. 1, 2 or 3 cable glands**

**Type YOB**

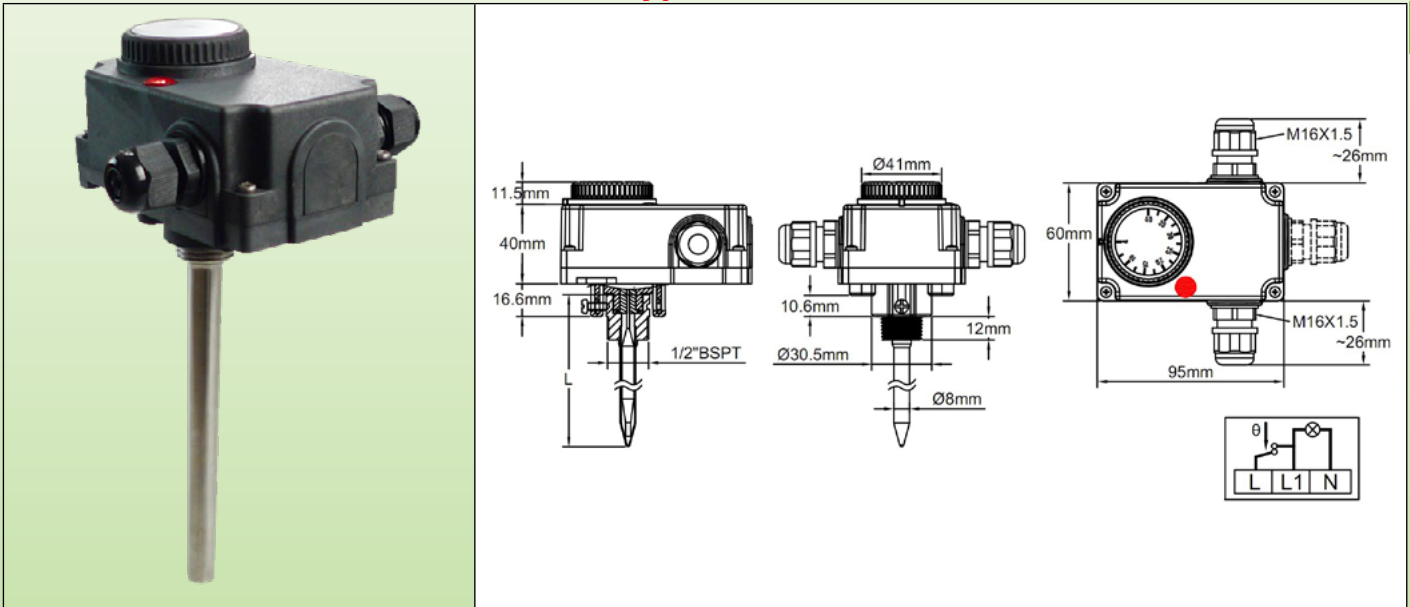

**Applications**

Temperature control of tanks or pipes in professional premises where good protection against liquid splashes or dust is requested.

Output with 2 or 3 cable glands, allowing direct connection of immersion heaters.

**Housing:** Small height, IP44, 95 × 60 × 40 mm, (Knob and cable glands not included), black PC-ABS, UL94V0. High impact and UV resistance. 2 removable wall mounting lugs.

**Electrical input:** M16 cable glands. Delivered with 2 cable glands (3 on request). Positioning the cable glands allows variations in the mounting position

**Temperature adjustment:** With °C printed knob. (°F printed knobs available in option)

**Sensing element:** Liquid filled bulb, located inside a backside mounted 304L stainless steel pocket.

**Adjustment ranges:** -35+35°C (-30+95°F), 4-40°C (40-105°F), 30-90°C (85-195°F), 30-110°C (90-230°F)

**Rod length:** 90, 230, 300 mm. Other length on request

**Mounting:**

- by the ½"BSPT (Tapped) pocket fitting (nickel plated brass pocket)

- by the ½"BSPP (parallel) pocket fitting (stainless steel pocket)

**Electrical connections:** On screw terminals. (It is possible to connect 2 wires 1.5mm<sup>2</sup> on each terminal.)

**Contact:** SPNC (open on temperature rise). One terminal is available for neutral connection. SPDT contact available on request but it is not compatible with neutral terminal and pilot light.

**Electrical rating:** 16A (2.6) 250VAC

- Electrical life >100,000 cycles.

**Main references with nickel plated brass pocket\***

Temperature ranges (°C)	Temperature ranges (°F)	References in °C with rod length L=90 mm**	References in °C with rod length L=230 mm**	References in °C with rod length L=300 mm**	Differential	Max temperature on rod
-35+35°C	-30+95°F		YOB8GD-35035N23J	YOB8GD-35035N30J	3±2°C (5.5±4°F)	55°C (130°F)
4-40°C	40-105°F		YOB8GD004040N23J	YOB8GD004040N30J	3±2°C (5.5±4°F)	60°C (140°F)
30-90°C	85-195°F	YOB8GD030090N09J	YOB8GD030090N23J	YOB8GD030090N30J	4±3°C (7±5.5°F)	120°C (250°F)
30-110°C	90-230°F	YOB8GD030110N09J	YOB8GD030110N23J	YOB8GD030110N30J	5±3°C (9±7°F)	150°C (300°F)

# Rod thermostat, 2 or 3 cable gland IP44 enclosure, for heat control, with built-in pilot light. Stainless steel or nickel plated brass pocket



## Main references with AISI 304 pocket\*

Temperature ranges (°C)	Temperature ranges (°F)	References in °C with rod length L=90 mm**	References in °C with rod length L=230 mm**	References in °C with rod length L=300 mm**	Differential	Max temperature on rod
-35+35°C	-30+95°F		Y0B8GD-35035I23J	Y0B8GD-35035I30J	3±2°C (5.5±4°F)	55°C (130°F)
4-40°C	40-105°F		Y0B8GD004040I23J	Y0B8GD004040I30J	3±2°C (5.5±4°F)	60°C (140°F)
30-90°C	85-195°F	Y0B8GD030090I09J	Y0B8GD030090I23J	Y0B8GD030090I30J	4±3°C (7±5.5°F)	120°C (250°F)
30-110°C	90-230°F	Y0B8GD030110I09J	Y0B8GD030110I23J	Y0B8GD030110I30J	5±3°C (9±7°F)	150°C (300°F)

Other temperature range, consult us

\* 3 cable gland version: replace C8G by C8H in the reference

\*\* Versions with °F printed knobs: replace the last character J by K in the reference

## Knob printings

°C Printing				°F Printing			
-35+35°C	4-40°C	30-90°C	30-110°C	-30+90°F	40-105°F	85-195°F	85-230°F

Because of permanent improvement of our products, drawings, descriptions, features used on these data sheets are for guidance only and can be modified without prior advice





Because of permanent improvement of our products, drawings, descriptions, features used on these data sheets are for guidance only and can be modified without prior advice

# Combination of adjustable set point thermostat and manual reset high limit, IP54 commercial housing, types **Y06** (With 1/2"BSPT nickel plated brass pocket) and **Y07** (AISI 304 pocket, 1/2"BSPP)

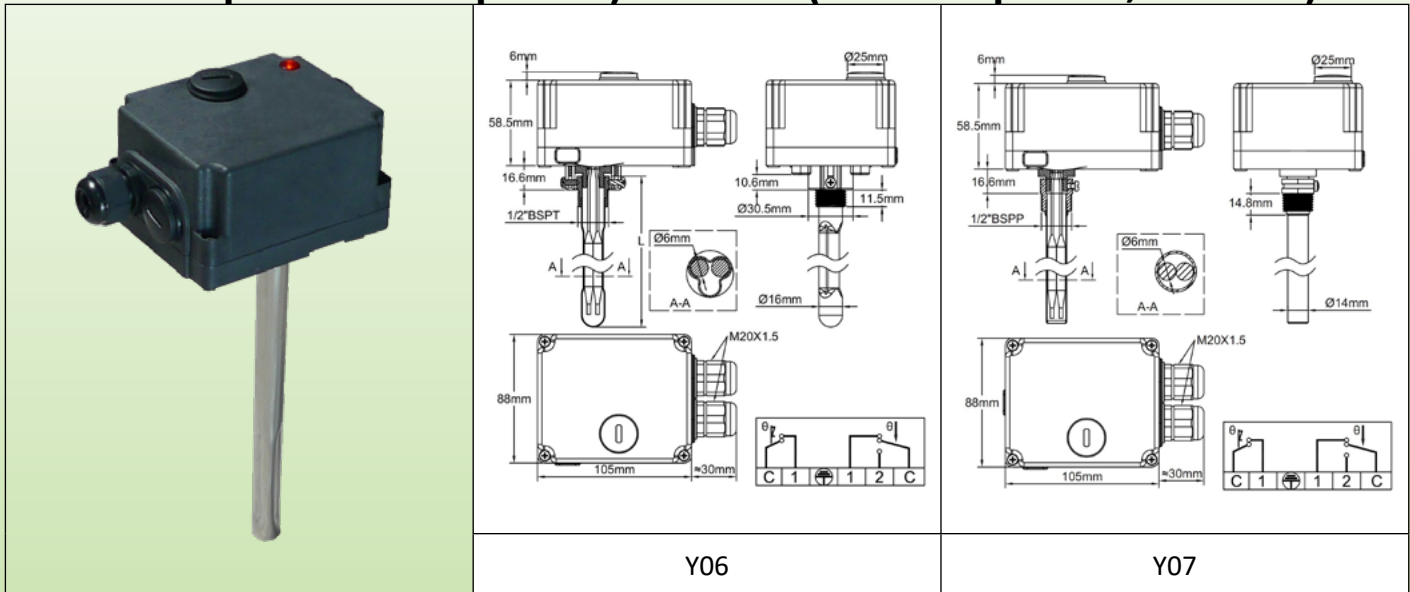

## Main applications

Temperature control and safety on storage water heaters, solar heating tanks, boilers.

**Housing:** IP54, 105 × 88 × 58.5 mm, (Cap, accessories and cable gland not included), black PC-ABS, UL94V0. High impact and UV resistance.

Product including an adjustable temperature control thermostat and a fixed setting high limit manual reset thermostat. Manual reset has access from outside, by removing a cap.

**Electrical input:** two M20 cable glands.

**Temperature Adjustment:** Inside, with °C printed knob. (°F printed knobs available in option)

**Sensing element:** Liquid filled bulb, located inside a backside mounted nickel plated brass pocket.

**Adjustment ranges:** 0-60°C (32-140°F); 30-90°C (85-195°F); 30-110°C (90-230°F)

**Pocket length (L):** 205mm (standard), 170, 300, 450 and 600mm on request

**Electrical connections:** screw terminals

### Mounting:

- Y06: by the 1/2"BSPT (taped) brass pocket fitting
- Y07: by the 1/2"BSPP (parallel) brass pocket fitting

### Control thermostat contact: SPDT

- Open on temperature rise contact (C-1) 16A (2.6) 250VAC
- Close on temperature rise contact (C-2) 6A (0.6) 250VAC
- Electrical life >100,000 cycles.

**Manual reset thermostat contact: Failsafe**, open by temperature rise; 16A (2,6) 250V alt.

### Options:

- Power supply "energized" pilot light (Neutral is mandatory, and thermostat contact is open on rise only, not SPDT). Other pilot light wirings are possible on request.
- Lifiable adjustable high end adjustment on control thermostat.
- Outside access to the control thermostat adjustment (By removing a 40mm dia. cap)
- Thermal cut out incorporated inside the pocket.
- These products can be made without pocket, for special customer applications and incorporation.

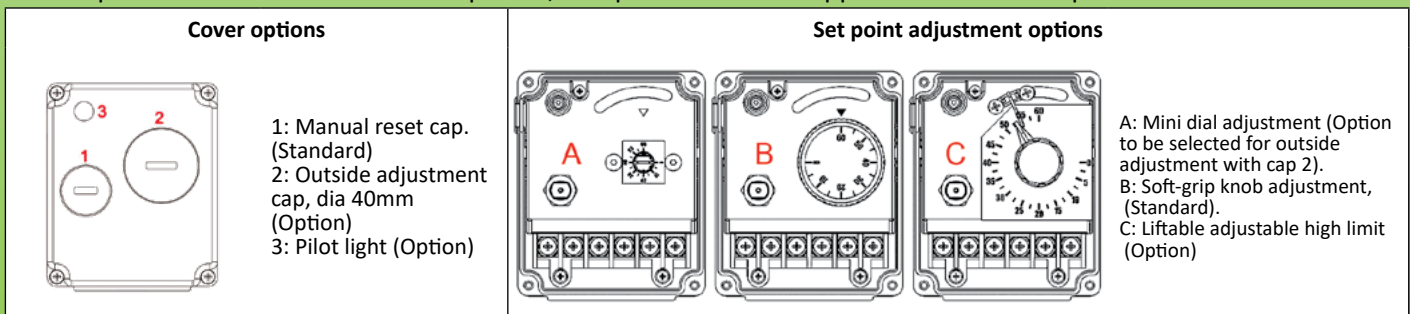



## Main references (with 205mm pocket)

Temperature ranges °C (°F)	Manual reset calibration °C (°F)	Cap access manual reset	Cap access manual reset, liftable adjustable high stop	Cap access manual reset, liftable adjustable high stop, power supply "on" pilot (230V)	Differential °C (°F)	Max temperature on rod °C (°F)
0-60°C (32-140°F)	80°C (176°F)	Y06MS00060A20080	Y06ME00060A20080	Y06NE00060C20080	4±3°C (7±5.5°F)	90°C (195°F)
30-90°C (85-195°F)	110°C (230°F)	Y06MS30090A20110	Y06ME30090A20110	Y06NE30090C20110	4±3°C (7±5.5°F)	120°C (250°F)
30-110°C (90-230°F)	130°C (266°F)	Y06MS30110A20130	Y06ME30110A20130	Y06NE30110C20130	5±3°C (9±7°F)	150°C (300°F)

Aisi 304 pocket: replace Y06 by Y07.

Versions with °F printed knobs: replace S by T or E by G in the reference.

## Knob and dial printings

Type	°C Printing			°F Printing		
	0-60°C	30-90°C	30-110°C	32-140°F	85-195°F	90-230°F
Standard softgrip knob						
Miniature knob dial for outside adjustment						
Adjustable stop big dial						

Because of permanent improvement of our products, drawings, descriptions, features used on these data sheets are for guidance only and can be modified without prior advice

# Rod thermostats, temperature control



Because of permanent improvement of our products, drawings, descriptions, features used on these data sheets are for guidance only and can be modified without prior advice

Enclosure	Type	Operation	Contact	Measurement	Ranges °C	Models
IP65 IK10	Control	Mechanical	SPDT	Rod		<b>Y1S8G</b> <b>Y1R8G</b>
Material						
Aluminum						

<p><b>Y1S8G: External adjustment</b> (With pilot light)</p>		<p><b>Y1R8G: Internal adjustment</b> (Without pilot light)</p>	
---	--	--	--

## Applications

These **liquid expansion** rod thermostats can be installed inside pockets as immersion thermostats in pipelines and containers, and for monitoring temperature in air ducts, in usual industrial applications and environments. (Not suitable for hazardous areas).

- Internal adjustment is convenient for products that must not be frequently adjusted.
- **Insensibility to strong vibrations**

**Housing:** Aluminum, IP65, IK10. Grey RAL7032 epoxy painting. Stainless steel captive cover screws. Captive aluminum lid.

**Set point adjustment ranges:** -35+35°C (-30+95°F); -10+40°C (15-105°F); 4-40°C (40-105°F); 0-60°C (32-140°F); 0-90°C (32-195°F); 30-90°C (85-195°F); 30-110°C (85-230°F); 50-200°C (120-390°F); 50-300°C (120-570°F); 100-400°C (210-750°F); 100-500°C (210-930°F)

**Set point adjustment:** By °C printed knob. All types have an adjustable rotation limit system located inside the knob that allows reducing the set point adjustment span. Types with external adjustment have a transparent window. This device allows seeing the pilot light and the knob position. °F values are available as an option.

**Action:** Temperature control, On-Off action.

**Sensing element:** Liquid expansion rod. This rod has a non-temperature sensing zone named dead zone which allows thermal insulation crossing. An increased diameter under the thermostat head allows mounting pockets, coolers or brackets (See pockets in the accessories section)

**Electrical connections:** Inside, on screw terminal connection block.

**Earthing:** Internal and external screw terminal.

**Pilot light:** Allow to visualize thermostat contact output position. Standard for all models with transparent window. Non Standard and on special request only for models with plain aluminum cover.

**Cable input and output:** Two M20 cable glands, Black PA66.

**Identification:** Metallic identification label, riveted.

**Contact:** SPDT

**Electrical rating, resistive loads:**

- Open on temperature rise contact (C-1)  
16A 250V, 50 ~60Hz: >100000 cycles,  
20A 250V, 50 ~60Hz: ≥50000 cycles,  
10A 400V, 50 ~60Hz: ≥50000 cycles.
- Close on temperature rise contact (C-2): 6A 250V 50 ~60Hz: >100000 cycles

**Electrical rating, inductive loads:**

- Open on temperature rise contact (C-1): 6A 250V, 50 ~60Hz: >100000 cycles
- Close on temperature rise contact (C-2): 0.6A 250V 50 ~60Hz: >100000 cycles

**Minimum storage temperature:** -35°C (-30°F)

**Maximum ambient temperature:** 60°C (140°F)

For more technical information ask 8G thermostat technical data sheet (catalog 1.)

# Rod thermostats, temperature control



## Main references\*

Temperature range °C (°F)	Reference with external adjustment	Reference with internal adjustment	Rod length* (L, mm)	Rod diameter (D, mm)	Temperature sensing length (mm)	Differential °C (°F)	Max temperature on rod °C (°F)
-35+35°C (-30+95°F)	Y1S8G5035AO1023J	Y1R8G5035AO1023J	230	10	140	1.6±1°C (2.9±2°F)	60°C (140°F)
-35+35°C (-30+95°F)	Y1S8G5035AO1030J	Y1R8G5035AO1030J	300	10	140	1.6±1°C (2.9±2°F)	60°C (140°F)
-10+40°C (15-105°F)	Y1S8G0040AO1023J	Y1R8G0040AO1023J	230	10	140	1.5±1°C (2.7±2°F)	70°C (158°F)
-10+40°C (15-105°F)	Y1S8G0040AO1030J	Y1R8G0040AO1030J	300	10	140	1.5±1°C (2.7±2°F)	70°C (158°F)
4-40°C (40-105°F)	Y1S8G4040AO1023J	Y1R8G4040AO1023J	230	10	140	1±0.5°C (1.8±1°F)	70°C (158°F)
4-40°C (40-105°F)	Y1S8G4040AO1030J	Y1R8G4040AO1030J	300	10	140	1±0.5°C (1.8±1°F)	70°C (158°F)
4-40°C (40-105°F)	Y1S8G4040AO1045J	Y1R8G4040AO1045J	450	10	140	1±0.5°C (1.8±1°F)	70°C (158°F)
0-60°C (32-140°F)	Y1S8G0060AO1023J	Y1R8G0060AO1023J	230	10	87	2.5±1°C (4.5±1.8°F)	80°C (176°F)
0-60°C (32-140°F)	Y1S8G0060AO1030J	Y1R8G0060AO1030J	300	10	87	2.5±1°C (4.5±1.8°F)	80°C (176°F)
0-60°C (32-140°F)	Y1S8G0060AO1045J	Y1R8G0060AO1045J	450	10	87	2.5±1°C (4.5±1.8°F)	80°C (176°F)
0-60°C (32-140°F)	Y1S8G0060AO1060J	Y1R8G0060AO1060J	600	10	87	2.5±1°C (4.5±1.8°F)	80°C (176°F)
0-90°C (32-195°F)	Y1S8G0090AO1023J	Y1R8G0090AO1023J	230	10	87	2.5±1°C (4.5±1.8°F)	120°C (250°F)
0-90°C (32-195°F)	Y1S8G0090AO1030J	Y1R8G0090AO1030J	300	10	87	2.5±1°C (4.5±1.8°F)	120°C (250°F)
0-90°C (32-195°F)	Y1S8G0090AO1045J	Y1R8G0090AO1045J	450	10	87	2.5±1°C (4.5±1.8°F)	120°C (250°F)
0-90°C (32-195°F)	Y1S8G0090AO1060J	Y1R8G0090AO1060J	600	10	87	2.5±1°C (4.5±1.8°F)	120°C (250°F)
30-90°C (85-195°F)	Y1S8G3090AO1023J	Y1R8G3090AO1023J	230	10	87	2.5±1°C (4.5±1.8°F)	120°C (250°F)
30-90°C (85-195°F)	Y1S8G3090AO1030J	Y1R8G3090AO1030J	300	10	87	2.5±1°C (4.5±1.8°F)	120°C (250°F)
30-90°C (85-195°F)	Y1S8G3090AO1045J	Y1R8G3090AO1045J	450	10	87	2.5±1°C (4.5±1.8°F)	120°C (250°F)
30-90°C (85-195°F)	Y1S8G3090AO1060J	Y1R8G3090AO1060J	600	10	87	2.5±1°C (4.5±1.8°F)	120°C (250°F)
30-110°C (85-230°F)	Y1S8G3110AO1023J	Y1R8G3110AO1023J	230	10	83	2.5±1°C (4.5±1.8°F)	140°C (284°F)
30-110°C (85-230°F)	Y1S8G3110AO1030J	Y1R8G3110AO1030J	300	10	83	2.5±1°C (4.5±1.8°F)	140°C (284°F)
30-110°C (85-230°F)	Y1S8G3110AO1045J	Y1R8G3110AO1045J	450	10	83	2.5±1°C (4.5±1.8°F)	140°C (284°F)
30-110°C (85-230°F)	Y1S8G3110AO1060J	Y1R8G3110AO1060J	600	10	83	2.5±1°C (4.5±1.8°F)	140°C (284°F)
50-200°C (120-390°F)	Y1S8G5200AO1023J	Y1R8G5200AO1023J	230	10	59	4±2°C (7±3.6°F)	230°C (446°F)
50-200°C (120-390°F)	Y1S8G5200AO1030J	Y1R8G5200AO1030J	300	10	59	4±2°C (7±3.6°F)	230°C (446°F)
50-200°C (120-390°F)	Y1S8G5200AO1045J	Y1R8G5200AO1045J	450	10	59	4±2°C (7±3.6°F)	230°C (446°F)
50-200°C (120-390°F)	Y1S8G5200AO1060J	Y1R8G5200AO1060J	600	10	59	4±2°C (7±3.6°F)	230°C (446°F)
50-300°C (120-570°F)	Y1S8G5300AO0823J	Y1R8G5300AO0823J	230	8	165	10°C±2°C (18±3.6°F)	330°C (626°F)
50-300°C (120-570°F)	Y1S8G5300AO0830J	Y1R8G5300AO0830J	300	8	165	10°C±2°C (18±3.6°F)	330°C (626°F)
50-300°C (120-570°F)	Y1S8G5300AO0845J	Y1R8G5300AO0845J	450	8	165	10°C±2°C (18±3.6°F)	330°C (626°F)
50-300°C (120-570°F)	Y1S8G5300AO0860J	Y1R8G5300AO0860J	600	8	165	10°C±2°C (18±3.6°F)	330°C (626°F)
100-400°C (210-750°F)	Y1S8GA400AO0823J	Y1R8GA400AO0823J	230	8	165	10°C±2°C (18±3.6°F)	430°C (800°F)
100-400°C (210-750°F)	Y1S8GA400AO0830J	Y1R8GA400AO0830J	300	8	165	10°C±2°C (18±3.6°F)	430°C (800°F)
100-400°C (210-750°F)	Y1S8GA400AO0845J	Y1R8GA400AO0845J	450	8	165	10°C±2°C (18±3.6°F)	430°C (800°F)
100-400°C (210-750°F)	Y1S8GA400AO0860J	Y1R8GA400AO0860J	600	8	165	10°C±2°C (18±3.6°F)	430°C (800°F)
100-500°C (210-930°F)	Y1S8GA500AN0830J	Y1R8GA500AN0830J	300	8	250	10°C±2°C (18±3.6°F)	550°C (1000°F)
100-500°C (210-930°F)	Y1S8GA500AN0845J	Y1R8GA500AN0845J	450	8	250	10°C±2°C (18±3.6°F)	550°C (1000°F)
100-500°C (210-930°F)	Y1S8GA500AN0860J	Y1R8GA500AN0860J	600	8	250	10°C±2°C (18±3.6°F)	550°C (1000°F)

\*F printing: replace last character (J) by K

\* Above 200°C we recommend to use a rod cooler reference 66RF07015 or 66RF0701F12 between the rod and the enclosure (see accessories).  
Caution: This cooler reduces the usable rod length by 70mm.

Because of permanent improvement of our products, drawings, descriptions, features used on these data sheets are for guidance only and can be modified without prior advice



# Rod thermostats, temperature control

## Knob printings

°C Printing					
0-10°C	-35+35°C	-10+40°C	4-40°C	0-60°C	0-90°C
30-90°C	30-110°C	50-200°C	50-300°C	100-400°C	100-500°C
°F Printing					
32-50°F	-30+90°F	15-105°F	40-105°F	30-140°F	30-195°F
85-195°F	85-230°F	120-390°F	120-570°F	210-750°F	210-930°F

Because of permanent improvement of our products, drawings, descriptions, features used on these data sheets are for guidance only and can be modified without prior advice





## Rod thermostats (bimetal expansion measurement)

Type	Adjustment	Contact	Measurement	Ranges °C	Model
<b>Control</b> 	<b>Internal</b> 	<b>Single pole</b> 	<b>Rod</b> 		<b>Y1U</b> <b>Thermostat</b> <b>1R, 1U</b>

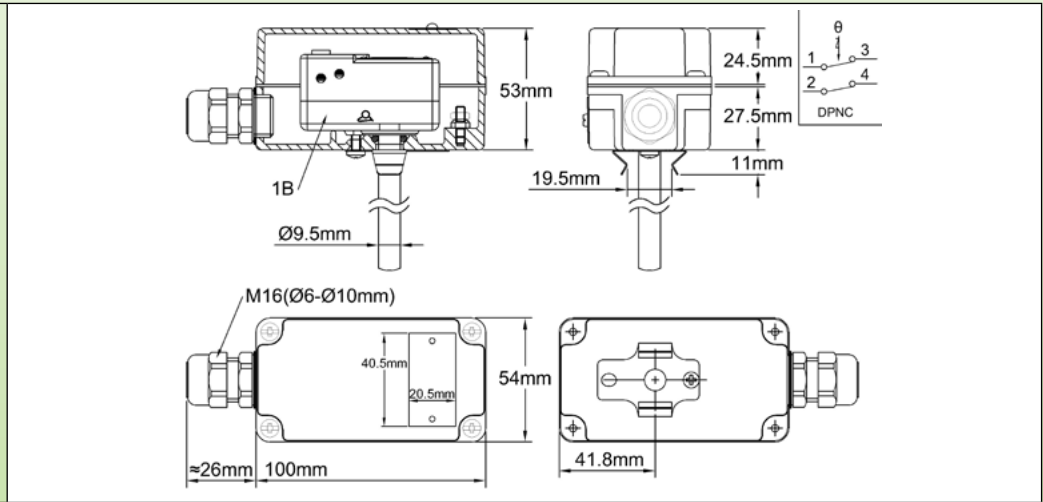

### Applications:

These **bimetal** rod thermostats can be installed inside pockets as immersion thermostats in pipelines and containers, and for monitoring temperature in air ducts, in usual industrial application and environment. (Not suitable for hazardous areas).

- **Small footprint enclosure**
- **Internal adjustment is convenient for products that must not be frequently adjusted.**
- **Short response time**
- **Low sensibility to strong vibrations**

*Long electrical and mechanical life model*

**Housing:** Aluminum, IP65, IK10, 100 × 53 × 54mm. Grey RAL7032 epoxy painting

**Set point adjustment ranges:** **10+130°C (+14+264°F)**, **+15+95 °C (+59+203°F)**, **+25+165°C (+77+329°F)**.

**Temperature adjustment:** Set point adjustable by **arrow style knob, on °C printed dial**. Consult us for °F versions

**Action:** temperature control.

**Sensing element:** Bimetal rod, stainless steel-Invar. A clip under the thermostat head allows mounting pockets or brackets (See pockets in the accessories section)

**Electrical connections:** on thermostat screw terminals

**Earthing:** on internal screw terminal

**Cable output:** M16 cable gland, PA66, for cables up to 10 mm dia.

**Mounting:** on pockets for liquid immersion or flange for air ducts

**Identification:** 20 × 40 mm stainless steel identification label, riveted.

**Contact:** SPDT

**Electrical rating:**

- Standard differential: 15A (4)A 250V/400VAC. Res.
- Reduced differential: 4 (1A) 250VAC. Res.

Electrical life > **100.000 cycles**.

Reduced differential models cannot be used in 400VAC

**Storage minimum temperature:** -50°C (-60°F)





### Main references

Temperature range °C (°F)	Rod length (mm)	Reference with standard differential	Differential value °C (°F)	Reference with reduced differential	Differential value °C (°F)	Max. temperature on rod °C (°F)
-10+130°C (+14+264°F)	200	Y1U1RA-10130B20L	15±5°C (27±9°F)	Y1U1UA-10130B20L	3±1.5°C (5.4±2.7°F)	180°C (356°F)
+15+95°C (+59+203°F)	200	Y1U1RA015095B20L	15±5°C (27±9°F)	Y1U1UA015095B20L	3±1.5°C (5.4±2.7°F)	145°C (293°F)
+15+95°C (+59+203°F)	300	Y1U1RA015095B30L	10±3°C (18±5.4°F)	Y1U1UA015095B30L	2±1°C (3.6±1.8°F)	145°C (293°F)
+25+165°C (+77+329°F)	200	Y1U1RA025165B20L	15±5°C (27±9°F)	Y1U1UA025165B20L	3±1.5°C (5.4±2.7°F)	215°C (419°F)



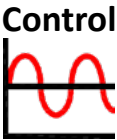

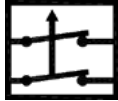
## Rod thermostats (bimetal expansion measurement)

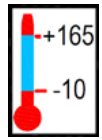
Type	Adjustment	Contact	Measurement	Range °C	Model
					<b>Y1U</b> <b>Thermostat</b> <b>1B, 1C</b>

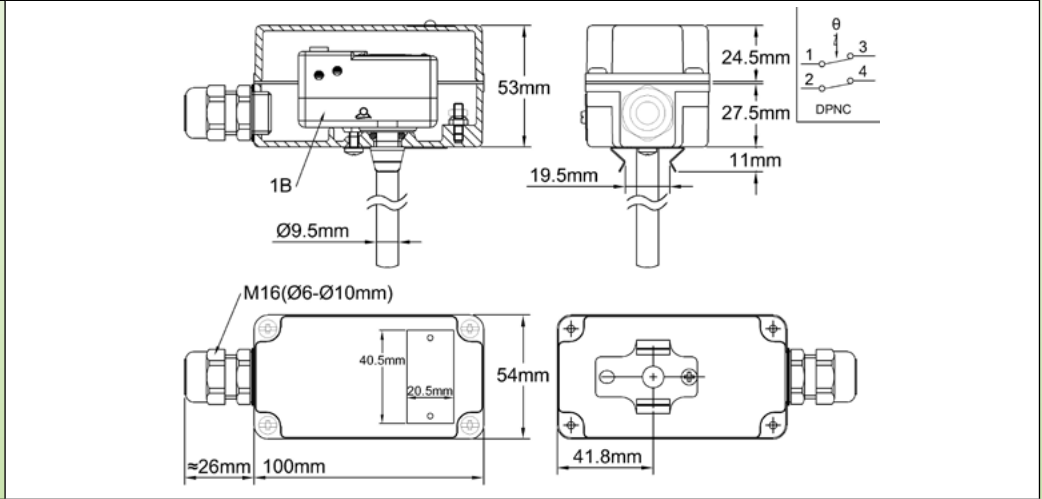

### Applications:

These **bimetal** rod thermostats can be installed inside pockets as immersion thermostats in pipelines and containers, and for monitoring temperature in air ducts, in usual industrial application and environment. (Not suitable for hazardous areas).

- **Small footprint enclosure**
- **Internal adjustment is convenient for products that must not be frequently adjusted.**
- **Short response time**
- **Low sensibility to strong vibrations**

*Long electrical and mechanical life model*

**Housing:** Aluminum, IP65, IK10, 100 × 53 × 54mm. Grey RAL7032 epoxy painting

**Set point adjustment ranges:** **10+130°C (+14+264°F)**, **+15+95 °C (+59+203°F)**, **+25+165°C (+77+329°F)**.

**Temperature adjustment:** Set point adjustable by **arrow style knob, on °C printed dial**. Consult us for °F versions

**Action:** temperature control.

**Sensing element:** Bimetal rod, stainless steel-Invar. A clip under the thermostat head allows mounting pockets or brackets (See pockets in the accessories section)

**Electrical connections:** on thermostat screw terminals

**Earthing:** on internal screw terminal

**Cable output:** M16 cable gland, PA66, for cables up to 10 mm dia.

**Mounting:** on pockets for liquid immersion or flange for air ducts

**Identification:** 20 × 40 mm stainless steel identification label, riveted.

**Contact:** DPNC

**Electrical rating:**

- Standard differential: 15A (4)A 250V/400VAC. Res.

- Reduced differential: 4 (1A) 250VAC. Res.

Electrical life > **100.000 cycles**.

Reduced differential models cannot be used in 400VAC

**Storage minimum temperature:** -50°C (-60°F)

### Main references

Temperature range °C (°F)	Rod length (mm)	Reference with standard differential	Differential value °C (°F)	Reference with reduced differential	Differential value °C (°F)	Max. temperature on rod °C (°F)
-10+130°C (+14+264°F)	200	Y1U1BA-10130B20L	15±5°C (27±9°F)	Y1U1CA-10130B20L	3±1.5°C (5.4±2.7°F)	180°C (356°F)
+15+95°C (+59+203°F)	200	Y1U1BA015095B20L	15±5°C (27±9°F)	Y1U1CA015095B20L	3±1.5°C (5.4±2.7°F)	145°C (293°F)
+15+95°C (+59+203°F)	300	Y1U1BA015095B30L	10±3°C (18±5.4°F)	Y1U1CA015095B30L	2±1°C (3.6±1.8°F)	145°C (293°F)
+25+165°C (+77+329°F)	200	Y1U1BA025165B20L	15±5°C (27±9°F)	Y1U1CA025165B20L	3±1.5°C (5.4±2.7°F)	215°C (419°F)



## 3 pole rod thermostats, temperature control

Enclosure	Type	Operation	Contact	Measurement	Ranges °C	Models
IP65 IK10	Control	Mechanical	3PST	Rod		<b>Y1S8C</b> <b>Y1R8C</b>
Material						
Aluminum						
Y1S8C: External adjustment				Y1R8C: Internal adjustment		

### Applications

These **liquid expansion** rod thermostats can be installed inside pockets as immersion thermostats in pipelines and containers, and to control temperature in air ducts, in usual industrial application and environment, on 3 phase heating circuits (Not suitable for hazardous areas).

- Internal adjustment is convenient for products that must not be frequently adjusted.

- **Insensitivity to strong vibrations**

**Housing:** Aluminum, IP65, IK10. Grey RAL7032 epoxy painting. Stainless steel captive cover screws. Captive aluminum lid.

**Set point adjustment ranges:** -35+35°C (-30+95°F); -10+40°C (15-105°F); 4-40°C (40-105°F); 0-60°C (32-140°F); 0-90°C (32-195°F); 30-90°C (85-195°F); 30-110°C (85-230°F); 50-200°C (120-390°F); 50-300°C (120-570°F); 100-400°C (210-750°F).

**Set point adjustment:** By °C printed knob. All types have an adjustable rotation limit system located inside the knob that allows reducing the set point adjustment span. Types with external adjustment have a transparent window. This device allows seeing the pilot light and the knob position. °F values are available in option.

**Action:** Temperature control, On-Off action

**Sensing element:** Liquid expansion rod. This rod has a non-temperature sensing zone named dead zone which allows thermal insulation crossing. An increased diameter under the thermostat head allows mounting pockets, coolers or brackets (See pockets in the accessories section)

**Electrical connections:** Inside, on screw terminal connection block

**Earthing:** External screw terminal.

**Cable input and output:** Two M20 cable gland, Black PA66.

**Identification:** Metallic identification label, riveted.

**Contact:** 3PST, open on temperature rise

**Electrical rating, resistive loads:**

16A 250V, 50 ~60Hz: >100000 cycles,

20A 250V, 50 ~60Hz: ≥50000 cycles,

10A 400V, 50 ~60Hz: ≥50000 cycles.

**Minimum Storage temperature:** -35°C (-30°F)

**Maximum ambient temperature:** 60°C (140°F)

For more technical information see 8C thermostat technical data sheet.

Because of permanent improvement of our products, drawings, descriptions, features used on these data sheets are for guidance only and can be modified without prior advice



## 3 pole rod thermostats, temperature control

### Main references\*

Temperature range °C (°F)	Reference with external adjustment	Reference with internal adjustment	Rod length* (L, mm)	Rod diameter (D, mm)	Temperature sensing length (mm)	Differential °C (°F)	Max temperature on rod °C (°F)
-35+35°C (-30+95°F)	Y1S8C5035AO1023J	Y1R8C5035AO1023J	230	10	140	1.6±1°C (2.9±2°F)	60°C (140°F)
-35+35°C (-30+95°F)	Y1S8C5035AO1030J	Y1R8C5035AO1030J	300	10	140	1.6±1°C (2.9±2°F)	60°C (140°F)
-10+40°C (15-105°F)	Y1S8C0040AO1023J	Y1R8C0040AO1023J	230	10	140	1.5±1°C (2.7±2°F)	70°C (158°F)
-10+40°C (15-105°F)	Y1S8C0040AO1030J	Y1R8C0040AO1030J	300	10	140	1.5±1°C (2.7±2°F)	70°C (158°F)
4-40°C (40-105°F)	Y1S8C4040AO1023J	Y1R8C4040AO1023J	230	10	140	1±0.5°C (1.8±1°F)	70°C (158°F)
4-40°C (40-105°F)	Y1S8C4040AO1030J	Y1R8C4040AO1030J	300	10	140	1±0.5°C (1.8±1°F)	70°C (158°F)
4-40°C (40-105°F)	Y1S8C4040AO1045J	Y1R8C4040AO1045J	450	10	140	1±0.5°C (1.8±1°F)	70°C (158°F)
0-60°C (32-140°F)	Y1S8C0060AO1023J	Y1R8C0060AO1023J	230	10	87	2.5±1°C (4.5±1.8°F)	80°C (176°F)
0-60°C (32-140°F)	Y1S8C0060AO1030J	Y1R8C0060AO1030J	300	10	87	2.5±1°C (4.5±1.8°F)	80°C (176°F)
0-60°C (32-140°F)	Y1S8C0060AO1045J	Y1R8C0060AO1045J	450	10	87	2.5±1°C (4.5±1.8°F)	80°C (176°F)
0-60°C (32-140°F)	Y1S8C0060AO1060J	Y1R8C0060AO1060J	600	10	87	2.5±1°C (4.5±1.8°F)	80°C (176°F)
0-90°C (32-195°F)	Y1S8C0090AO1023J	Y1R8C0090AO1023J	230	10	87	2.5±1°C (4.5±1.8°F)	120°C (250°F)
0-90°C (32-195°F)	Y1S8C0090AO1030J	Y1R8C0090AO1030J	300	10	87	2.5±1°C (4.5±1.8°F)	120°C (250°F)
0-90°C (32-195°F)	Y1S8C0090AO1045J	Y1R8C0090AO1045J	450	10	87	2.5±1°C (4.5±1.8°F)	120°C (250°F)
0-90°C (32-195°F)	Y1S8C0090AO1060J	Y1R8C0090AO1060J	600	10	87	2.5±1°C (4.5±1.8°F)	120°C (250°F)
30-90°C (85-195°F)	Y1S8C3090AO1023J	Y1R8C3090AO1023J	230	10	87	2.5±1°C (4.5±1.8°F)	120°C (250°F)
30-90°C (85-195°F)	Y1S8C3090AO1030J	Y1R8C3090AO1030J	300	10	87	2.5±1°C (4.5±1.8°F)	120°C (250°F)
30-90°C (85-195°F)	Y1S8C3090AO1045J	Y1R8C3090AO1045J	450	10	87	2.5±1°C (4.5±1.8°F)	120°C (250°F)
30-90°C (85-195°F)	Y1S8C3090AO1060J	Y1R8C3090AO1060J	600	10	87	2.5±1°C (4.5±1.8°F)	120°C (250°F)
30-110°C (85-230°F)	Y1S8C3110AO1023J	Y1R8C3110AO1023J	230	10	83	2.5±1°C (4.5±1.8°F)	140°C (284°F)
30-110°C (85-230°F)	Y1S8C3110AO1030J	Y1R8C3110AO1030J	300	10	83	2.5±1°C (4.5±1.8°F)	140°C (284°F)
30-110°C (85-230°F)	Y1S8C3110AO1045J	Y1R8C3110AO1045J	450	10	83	2.5±1°C (4.5±1.8°F)	140°C (284°F)
30-110°C (85-230°F)	Y1S8C3110AO1060J	Y1R8C3110AO1060J	600	10	83	2.5±1°C (4.5±1.8°F)	140°C (284°F)
50-200°C (120-390°F)	Y1S8C5200AO1023J	Y1R8C5200AO1023J	230	10	59	4±2°C (7±3.6°F)	230°C (446°F)
50-200°C (120-390°F)	Y1S8C5200AO1030J	Y1R8C5200AO1030J	300	10	59	4±2°C (7±3.6°F)	230°C (446°F)
50-200°C (120-390°F)	Y1S8C5200AO1045J	Y1R8C5200AO1045J	450	10	59	4±2°C (7±3.6°F)	230°C (446°F)
50-200°C (120-390°F)	Y1S8C5200AO1060J	Y1R8C5200AO1060J	600	10	59	4±2°C (7±3.6°F)	230°C (446°F)
50-300°C (120-570°F)	Y1S8C5300AO0823J	Y1R8C5300AO0823J	230	8	165	10±2°C (18±3.6°F)	330°C (626°F)
50-300°C (120-570°F)	Y1S8C5300AO0830J	Y1R8C5300AO0830J	300	8	165	10±2°C (18±3.6°F)	330°C (626°F)
50-300°C (120-570°F)	Y1S8C5300AO0845J	Y1R8C5300AO0845J	450	8	165	10±2°C (18±3.6°F)	330°C (626°F)
50-300°C (120-570°F)	Y1S8C5300AO0860J	Y1R8C5300AO0860J	600	8	165	10±2°C (18±3.6°F)	330°C (626°F)
100-400°C (210-750°F)	Y1S8CA400AO0823J	Y1R8CA400AO0823J	230	8	165	10±2°C (18±3.6°F)	430°C (800°F)
100-400°C (210-750°F)	Y1S8CA400AO0830J	Y1R8CA400AO0830J	300	8	165	10±2°C (18±3.6°F)	430°C (800°F)
100-400°C (210-750°F)	Y1S8CA400AO0845J	Y1R8CA400AO0845J	450	8	165	10±2°C (18±3.6°F)	430°C (800°F)
100-400°C (210-750°F)	Y1S8CA400AO0860J	Y1R8CA400AO0860J	600	8	165	10±2°C (18±3.6°F)	430°C (800°F)
100-500°C (210-930°F)	Y1S8CA500AN0830J	Y1R8CA500AN0830J	300	8	250	10±2°C (18±3.6°F)	550°C (1000°F)
100-500°C (210-930°F)	Y1S8CA500AN0845J	Y1R8CA500AN0845J	450	8	250	10±2°C (18±3.6°F)	550°C (1000°F)
100-500°C (210-930°F)	Y1S8CA500AN0860J	Y1R8CA500AN0860J	600	8	250	10±2°C (18±3.6°F)	550°C (1000°F)

\*F printing: replace last character (J) by K

\*Above 200°C we recommend to use a rod cooler reference 66RF07015 or 66RF0701F12 between the rod and the enclosure (see accessories). Caution: This cooler reduces the usable rod length of 70mm

Because of permanent improvement of our products, drawings, descriptions, features used on these data sheets are for guidance only and can be modified without prior advice

# 3 pole rod thermostats, temperature control



## Knob printings

°C Printing				
-35+35°C	-10+40°C	4-40°C	0-60°C	0-90°C
30-90°C	30-110°C	50-200°C	50-300°C	100-400°C
°F Printing				
-30+95°F	15-105°F	40-105°F	32-140°F	32-195°F
85-195°F	85-230°F	120-390°F	120-570°F	210-750°F

Because of permanent improvement of our products, drawings, descriptions, features used on these data sheets are for guidance only and can be modified without prior advice

## Rod thermostats, temperature control



Because of permanent improvement of our products, drawings, descriptions, features used on these data sheets are for guidance only and can be modified without prior advice

Enclosure	Type	Operation	Contact	Measurement	Ranges °C	Models
IP65 IK10	Control	Mechanical	SPDT	Rod		<b>YF4GNC</b>
Material						
PA66 & PC						

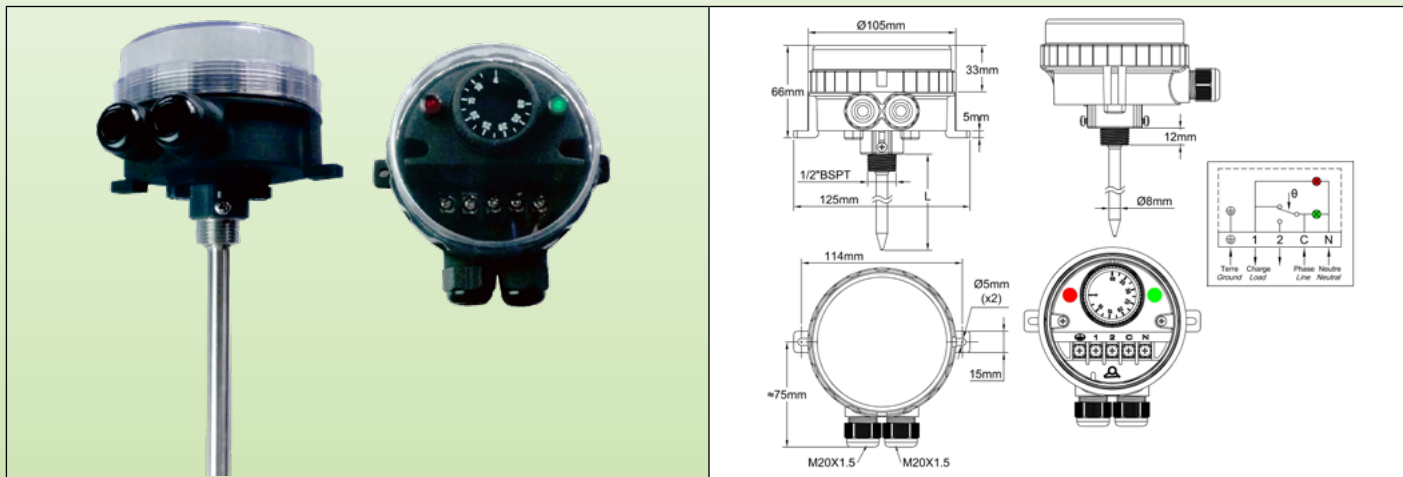

### Applications

- Equipment requesting a very strong resistance to water ingress. The transparent cover allows to visualize the set point and the 2 pilot lights

These liquid expansion rod thermostats can be installed inside pockets as immersion thermostats in pipelines and containers, and for monitoring temperature in air ducts, in usual industrial applications and environments. (Not suitable for hazardous areas).

**Housing:** Protection class IP 66 upon EN 60529 (waterproof spray water under high pressure and sea splashes, totally dust tight). Body in black PA66, fiber glass reinforced. The transparent polycarbonate cover can be unscrewed by hand, but it is also possible to use a hook spanner. Mechanical impact resistance: IK10. High UV resistance.

**Set point adjustment:** By °C printed knob. All types have an adjustable rotation limit system located inside the knob that allows reducing the set point adjustment span. °F printed knobs available as an option.

**Action:** Temperature control. On-Off action.

**Sensing element:** Liquid expansion bulb and capillary inside nickel plated brass pocket. Thread ½" BSPT. Tube outside diameter 10mm. Located at the bottom of the housing, 2 screws are used to secure standard pockets. (See the compatible stainless steel and brass pockets range in the accessories section)

**Pilot lights:** One pilot light visualizes the thermostat contact output position. The other visualizes the power supply input. Phase and line electrical supply is mandatory for these pilot lights.

**Set point adjustment ranges:** 4-40°C (40-105°F); 0-60°C (32-140°F); 0-90°C (32-195°F); 30-90°C (85-195°F); 30-110°C (85-230°F).

**Cable input and output:** Two M20 cable glands, built-in black PA66.

**Electrical connections:** Inside, on screw terminal connection block. It is possible to connect 2 wires 1.5mm<sup>2</sup> on each terminal.

**Earthing:** Internal screw terminal.

**Mounting:** By the pocket thread or by 2 legs with holes for screws dia. 4 to 5 mm, 114 mm distance.

**Identification:** Identification label on backside.

**Contact:** SPDT

**Electrical rating, resistive loads:**

- Open on temperature rise contact (C-1)

16A 250V, 50 ~60Hz: >100000 cycles,

20A 250V, 50 ~60Hz: ≥50000 cycles,

10A 400V, 50 ~60Hz: ≥50000 cycles.

- Close on temperature rise contact (C-2): 6A 250V 50 ~60Hz: >100000 cycles

**Electrical rating, inductive loads:**

- Open on temperature rise contact (C-1): 2.6A 250V, 50 ~60Hz: >100000 cycles

- Close on temperature rise contact (C-2): 0.6A 250V 50 ~60Hz: >100000 cycles.

**Minimum Storage temperature:** -35°C (-30°F)

**Maximum ambient temperature:** 60°C (140°F)

For more technical information ask 8G thermostat technical data sheet.





# Rod thermostats, temperature control

## Main references\*

Temperature range °C (°F)	References	Pocket length (L, mm)	Temperature sensing length (mm)	Differential °C (°F)	Max temperature on rod °C (°F)
4-40°C (40-105°F)	YF4GNC04040231ZJ	230	140	1±0.5°C (1.8±1°F)	70°C (158°F)
4-40°C (40-105°F)	YF4GNC04040301ZJ	300	140	1±0.5°C (1.8±1°F)	70°C (158°F)
4-40°C (40-105°F)	YF4GNC04040451ZJ	450	140	1±0.5°C (1.8±1°F)	70°C (158°F)
4-40°C (40-105°F)	YF4GNC04040601ZJ	600	140	1±0.5°C (1.8±1°F)	70°C (158°F)
0-60°C (32-140°F)	YF4GNC00060231ZJ	230	87	2.5±1°C (4.5±1.8°F)	80°C (176°F)
0-60°C (32-140°F)	YF4GNC00060301ZJ	300	87	2.5±1°C (4.5±1.8°F)	80°C (176°F)
0-60°C (32-140°F)	YF4GNC00060451ZJ	450	87	2.5±1°C (4.5±1.8°F)	80°C (176°F)
0-60°C (32-140°F)	YF4GNC00060601ZJ	600	87	2.5±1°C (4.5±1.8°F)	80°C (176°F)
0-90°C (32-195°F)	YF4GNC00090231ZJ	230	87	2.5±1°C (4.5±1.8°F)	120°C (250°F)
0-90°C (32-195°F)	YF4GNC00090301ZJ	300	87	2.5±1°C (4.5±1.8°F)	120°C (250°F)
0-90°C (32-195°F)	YF4GNC00090451ZJ	450	87	2.5±1°C (4.5±1.8°F)	120°C (250°F)
0-90°C (32-195°F)	YF4GNC00090601ZJ	600	87	2.5±1°C (4.5±1.8°F)	120°C (250°F)
30-90°C (85-195°F)	YF4GNC30090231ZJ	230	87	2.5±1°C (4.5±1.8°F)	120°C (250°F)
30-90°C (85-195°F)	YF4GNC30090301ZJ	300	87	2.5±1°C (4.5±1.8°F)	120°C (250°F)
30-90°C (85-195°F)	YF4GNC30090451ZJ	450	87	2.5±1°C (4.5±1.8°F)	120°C (250°F)
30-90°C (85-195°F)	YF4GNC30090601ZJ	600	87	2.5±1°C (4.5±1.8°F)	120°C (250°F)
30-110°C (85-230°F)	YF4GNC30110231ZJ	230	83	2.5±1°C (4.5±1.8°F)	140°C (284°F)
30-110°C (85-230°F)	YF4GNC30110301ZJ	300	83	2.5±1°C (4.5±1.8°F)	140°C (284°F)
30-110°C (85-230°F)	YF4GNC30110451ZJ	450	83	2.5±1°C (4.5±1.8°F)	140°C (284°F)
30-110°C (85-230°F)	YF4GNC30110601ZJ	600	83	2.5±1°C (4.5±1.8°F)	140°C (284°F)

\*F printing: replace last character (J) by K

## Knob printings

°C Printing				
4-40°C	0-60°C	0-90°C	30-90°C	30-110°C
°F Printing				
40-105°F	32-140°F	32-195°F	85-195°F	85-230°F

Because of permanent improvement of our products, drawings, descriptions, features used on these data sheets are for guidance only and can be modified without prior advice



**Adjustable set point rod thermostat, with high corrosion resistance housing, specifically designed for surface treatment baths, and highly basic or acid corrosive liquids or environments.**

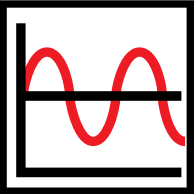
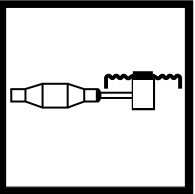
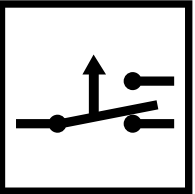
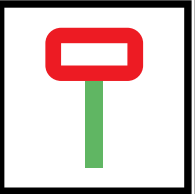
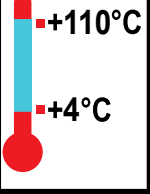

Because of permanent improvement of our products, drawings, descriptions, features used on these data sheets are for guidance only and can be modified without prior advice

Environnement	Type	Operation	Contact	Measurement	Ranges °C	Models
IP66 IK10	Control	Mechanical	SPDT	Rod	+110°C +4°C	<b>YF5GPP</b>
						

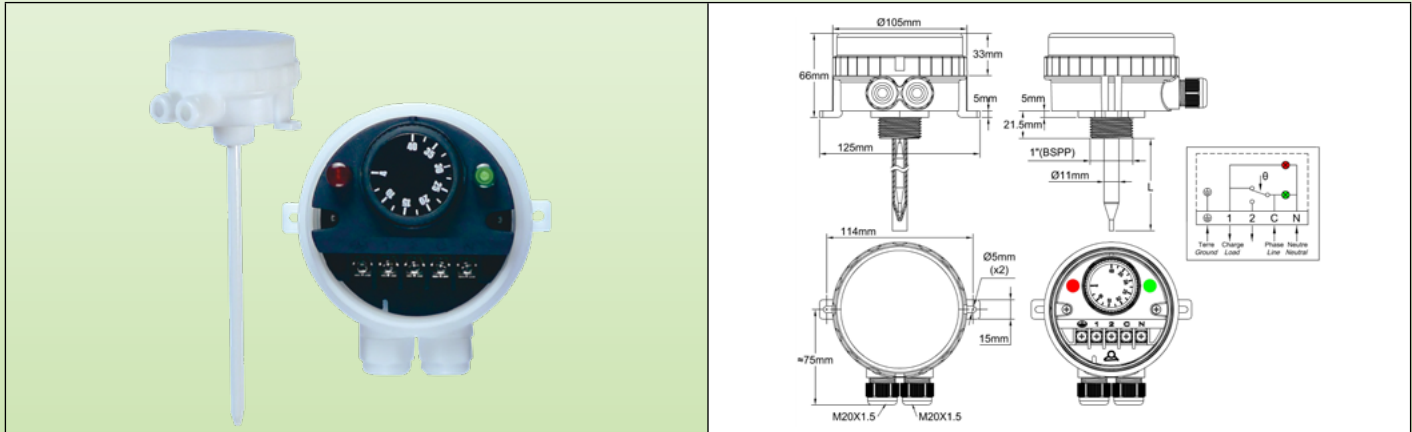

### Main applications

Temperature control for surface treatment or **corrosive** liquid baths, sea water environment, livestock premises.

**Housing:** Protection class IP 66 upon EN 60529 (waterproof spray water under high pressure and sea splashes, totally dust tight), dia. 105mm, height 66mm (excluding accessories and cable glands), made of plastic. Includes an adjustable thermostat that can be set after unscrewing the cover. To eliminate the enclosure risk of corrosion, there is no metallic part in contact with the external environment. Cover gasket and cable gland stuffing sets are made in EPDM. Rod seal is made of fluorocarbon elastomer FKM (Viton). The cover can be unscrewed by hand, but it is also possible to use a hook spanner.

**Electrical connections:** Cable input/output by two M20 cable glands. Electrical connection on screw terminals

**Temperature Adjustment:** Inside, with °C printed knob. (°F printed knobs available as an option). Knobs have an invisible device to reduce the temperature range span.

**Sensing element:** Liquid filled bulb,

**Adjustment ranges:** 4-40°C (32- 104°F); 0-60°C (32-140°F); 30-90°C (85-195°F); 30-110°C (90-230°F)

**Rod dimensions:** Outside diameter (D) before optional sleeving is 10mm. Length (L): 450mm, 600mm (300mm, 800mm and 1000mm on request )

**Rod material and sleeving:**

- SUS 316L without sleeving
- Titanium
- SUS 316L with shrunk PTFE sleeve, thickness 0.4 to 0.6mm

**Mounting:**

- By the 1" BSPT thread (Mounting through wall is watertight when used with the 1" nut and seal. See accessories)
- By a rotatable plastic bracket, enabling mounting on tank edge (See accessories)
- By the 2 legs on the side (2 holes dia 5 mm center distance 113 mm)

**Electrical contact:** SPDT

- Open on temperature rise contact (C-1) 16A (2.6) 250VAC
- Close on temperature rise contact (C-2) 6A (0.6) 250VAC
- Electrical life >100.000 cycles.

Power supply and power output pilot lights (Neutral is mandatory).

**Cover and housing material options:**

- Black PA66, glass filled body, and polycarbonate (PC) transparent cover, suitable for most applications in medium low to medium corrosive liquids, up to 90 °C. Allows viewing constantly input and output power supply and thermostat set point. Excellent mechanical strength of the housing (IK10). Very good UV resistance.
- Orange PP (polypropylene) body, with transparent polycarbonate (PC) cover: Very good resistance to strong bases, good resistance to acids. For use in liquids up to 90 °C. Allows to view constantly input and output power supply and thermostat set point. Reduced mechanical strength (IK8).
- Orange PP (polypropylene) body, with opaque orange PP (polypropylene) cover: Very good resistance to strong bases, good resistance to acids. For use in liquids up to 90 °C. Reduced mechanical strength (IK8).
- White PVDF body with opaque white PVDF cover: For use in liquid baths at temperatures above 90 °C and up to

**Adjustable set point rod thermostat, with high corrosion resistance housing, specifically designed for surface treatment baths, and highly basic or acid corrosive liquids or environments.**



110°C or strong oxidizing chemicals such as chrome electrolyte or nitric acid solution (HNO3). Reduced mechanical strength (IK8).

**Rod protection options (see also table below)**

- Stainless steel 316L-Ti without coating
- Stainless steel 316L, with FEP chemically deposited coating, thickness 0.2 to 0.4mm
- Stainless steel 316L, with PFA chemically deposited coating, thickness 0.2 to 0.4mm
- Stainless steel 316L, with PTFE chemically deposited coating, thickness 0.05 to 0.1mm
- Stainless steel 316L, with ETFE chemically deposited coating, thickness 0.2 to 0.4mm

**Main references with SS 316L rod, coated with shrunk PTFE\***

Temperature ranges °C (°F)	Rod length (L, mm)	Black PA66 housing, crystal clear PC cover	Orange PP housing, crystal clear PC cover	Orange PP housing, orange opaque PP cover	White PVDF housing, white opaque PVDF cover	Differential °C (°F)	Max temperature on rod °C (°F)
4-40°C (32-104°F)	450	YF5GNCS04040451P	YF5GPCS04040451P	YF5GPPS04040451P	YF5GVVS04040451P	2±1°C (3±1.5°F)	50°C (122°F)
0-60°C (32-140°F)	450	YF5GNCS00060451P	YF5GPCS00060451P	YF5GPPS00060451P	YF5GVVS00060451P	3.5±2.5°C (6±4.5°F)	90°C (195°F)
30-90°C (85-195°F)	450	YF5GNCS30090451P	YF5GPCS30090451P	YF5GPPS30090451P	YF5GVVS30090451P	4±3°C (7±5.5°F)	120°C (250°F)
30-110°C (90-230°F)	450	YF5GNCS30110451P	YF5GPCS30110451P	YF5GPPS30110451P	YF5GVVS30110451P	5±3°C (9±7°F)	150°C (300°F)
4-40°C (32-104°F)	600	YF5GNCS04040601P	YF5GPCS04040601P	YF5GPPS04040601P	YF5GVVS04040601P	2±1°C (3±1.5°F)	50°C (122°F)
0-60°C (32-140°F)	600	YF5GNCS00060601P	YF5GPCS00060601P	YF5GPPS00060601P	YF5GVVS00060601P	3.5±2.5°C (6±4.5°F)	90°C (195°F)
30-90°C (85-195°F)	600	YF5GNCS30090601P	YF5GPCS30090601P	YF5GPPS30090601P	YF5GVVS30090601P	4±3°C (7±5.5°F)	120°C (250°F)
30-110°C (90-230°F)	600	YF5GNCS30110601P	YF5GPCS30110601P	YF5GPPS30110601P	YF5GVVS30110601P	5±3°C (9±7°F)	120°C (250°F)

**Reference modifications vs options**

Rod length			Rod protection coating						
300mm	800mm	1000mm	316L without coating	316L-Ti without coating	Titanium	316L+ FEP 0.2~0.4mm*	316L+ PFA 0.2~0.4mm*	316L+ PTFE 0.05~0.1mm*	316L+ ETFE 0.2~0.4mm*
XXXXXXXXXXXX30xx	XXXXXXXXXXXX80xx	XXXXXXXXXXXXA0xx	XXXXXXXXXXXXU	XXXXXXXXXXXXV	XXXXXXXXXXXXW	XXXXXXXXXXXXQ	XXXXXXXXXXXXR	XXXXXXXXXXXXS	XXXXXXXXXXXXT

\* MOQ 100 pieces.

Versions with °F printed knobs: replace S by T in the reference (7th character)

**Accessories**

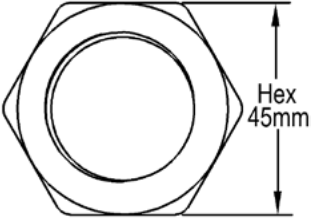
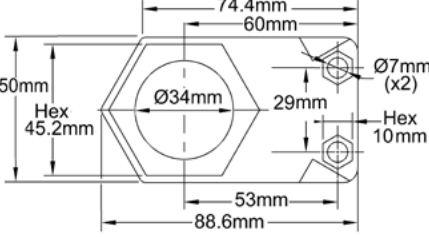
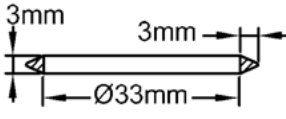
1" BSPP Nut, 5mm thickness	Bracket for tank side mounting, thickness 10mm (Assembly made with 1" nut)	1" gasket for through wall waterproof mounting with 1" nut
		
Reference in PA66: 66YFHN1N	Reference in PA66: 66YFMB1N	Reference in FKM (Viton): 66YGA1F
Reference in PP: 66YFHN1P	Reference in PP: 66YFMB1P	
Reference in PVDF: 66YFHN1V	Reference in PVDF: 66YFMB1V	

Because of permanent improvement of our products, drawings, descriptions, features used on these data sheets are for guidance only and can be modified without prior advice



Because of permanent improvement of our products, drawings, descriptions, features used on these data sheets are for guidance only and can be modified without prior advice

# Pipe mounting mechanical thermostats



Because of permanent improvement of our products, drawings, descriptions, features used on these data sheets are for guidance only and can be modified without prior advice



# Dia. 30 to 70mm pipe-mounting thermostats, with 2 built-in pilot lights

Because of permanent improvement of our products, drawings, descriptions, features used on these data sheets are for guidance only and can be modified without prior advice

Enclosure	Type	Operation	Contact	Measurement	Ranges °C	Models
IP55	Control	Mechanical	SPNC	Pipe		<h2 style="margin: 0;">Y2H Y2P</h2>
Material						
PC- ABS						

<p>Y2H: External adjustment</p>		<p>Y2P: Internal adjustment</p>	
---------------------------------	--	---------------------------------	--

**This thermostat is designed with a V shaped temperature sensitive nickel plated brass backside to improve thermal contact with the pipe, and two lugs for spring mounting. Suitable for pipes of 30 to 70mm diameter.**

**Housing:** PC-ABS, fiberglass reinforced, UL94V0. High impact and UV resistance, with waterproof gasket on thermostat shaft for external adjustment types. Internal adjustment types have a PC transparent cover, to visualize the pilot lights and the set point adjustment.

**Cable input:** ISO M20 cable gland, Black PA66, IP67, for cables from 6 to 12mm dia.

**Set point adjustment:** By °C printed knob for external adjustment models, by screw driver and printed dial on internal adjustment models. External adjustment types have an adjustable rotation limit system located inside the knob that allows reducing the set point adjustment span. °F values are available in option.

**Sensing element:** Liquid filled capillary, inside the nickel plated brass part in contact with the pipe.

**Adjustment ranges:** 30-90°C (85-195°F), 30-110°C (85-230°F)

**Pilot lights:** Allow to visualize the power supply and thermostat contact position (Phase and Neutral power supply is mandatory for pilot lights).

**Electrical connections:** On screw terminals. (It is possible to connect 2 wires 1.5mm<sup>2</sup> on each terminal). In option, an auxiliary connection block can be added, providing 3 neutral terminals.

**Mounting:** By spring on pipe.

**Contact:** SPNC (open on temperature rise).

**Electrical rating, resistive loads:**

16A 250V, 50 ~60Hz: >100000 cycles,

20A 250V, 50 ~60Hz: ≥50000 cycles,

10A 400V, 50 ~60Hz: ≥50000 cycles.

**Electrical rating, inductive loads:**

6A 250V, 50 ~60Hz: >100000 cycles

**Minimum Storage temperature:** -35°C (-30°F)

**Maximum ambient temperature:** 60°C (140°F)

For more technical information ask 8G thermostat technical data sheet.

### Main references

Temperature adjustment range °C (°F)	References with external adjustment	References with internal adjustment	Differential °C (°F)
30-90°C (85-195°F)	Y2H8GD030090AA8J	Y2P8GD030090AA8J	2.5±1°C (4.5±1.8°F)
30-110°C (85-230°F)	Y2H8GD030110AA8J	Y2P8GD030110AA8J	2.5±1°C (4.5±1.8°F)

Version with auxiliary 3 way neutral terminal: replace D0 by D1 in the reference

°F printing: replace last character (J) by K

### Knob printings

°C Printing		°F Printing	
30-90°C	30-110°C	85-195°F	90-230°F

# Pipe mounting thermostats



Enclosure	Type	Operation	Contact	Measurement	Ranges °C	Models
IP65 IK10	Control	Mechanical	SPDT	Pipe		<b>Y118G</b> <b>Y108G</b>
Material						
Aluminum						

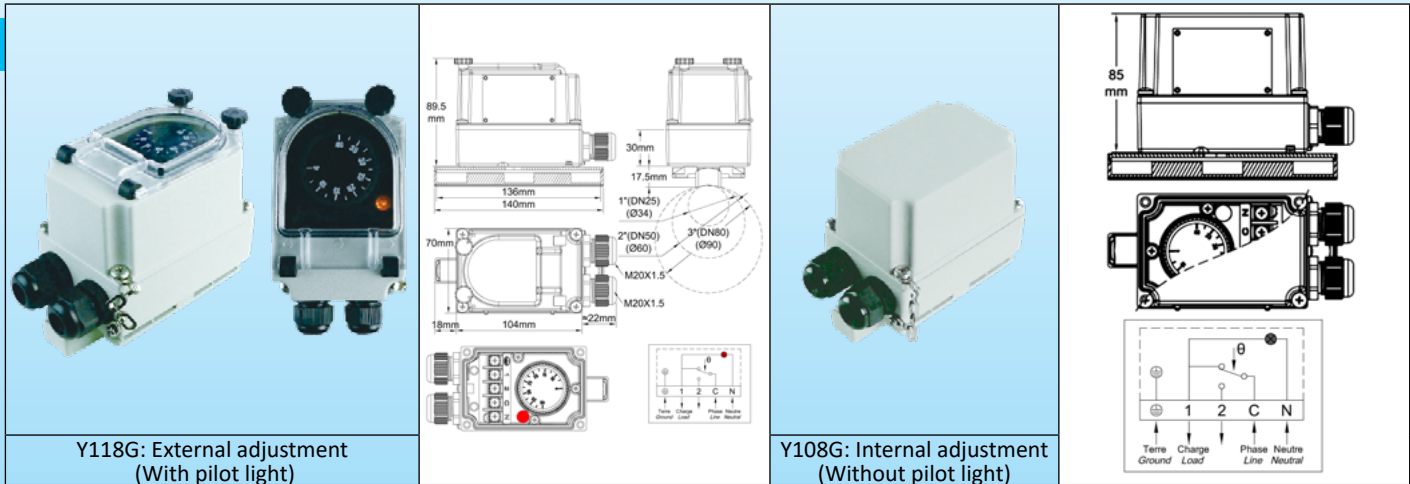

Because of permanent improvement of our products, drawings, descriptions, features used on these data sheets are for guidance only and can be modified without prior advice

## Applications:

Pipes surface temperature control in usual industrial applications and environments, (No suitable for hazardous areas)  
Internal adjustment is convenient for products that must not be frequently adjusted.

**Housing:** Aluminum, IP65, IK10. Grey RAL7032 epoxy painting. Stainless steel captive cover screws. Captive aluminum lid.

**Set point adjustment ranges:** 0-60°C (32-140°F); 0-90°C (32-195°F); 30-90°C (85-195°F); 30-110°C (85-230°F);

**Set point adjustment:** By °C printed knob. All types have an adjustable rotation limit system located inside the knob that allows reducing the set point adjustment span. Types with external adjustment have a transparent window. This device allows seeing the pilot light and the knob position. °F values are available as an option.

**Action:** Temperature control, On-Off action

**Sensing element:** Liquid expansion bulb inside aluminum bracket in contact with the pipe surface.

The bracket design provides optimized thermal contact with 34mm (1", DN25), 60mm (2", DN50) and 90mm (3", DN80) outside diameter tubes. For intermediate sizes, we recommend the use of thermal grease.

**Electrical connections:** Inside, on screw terminal connection block.

**Earthing:** Internal and external screw terminal.

**Pilot light:** Allows to visualize thermostat contact output position. Standard for all models with transparent window. Non Standard and on special request only for models with plain aluminum cover.

**Cable input and output:** Two M20 cable glands, Black PA66.

**Mounting:** The thermostat housing can be fixed on the pipe by worm drive hose clamps (DIN3017), nylon cable ties (Tie wraps upon EN50146, for applications at permanent temperature lower than 85°C), or specific stainless steel punched band (see accessories at the end of this catalog)

**Identification:** Metallic identification label, riveted.

**Contact:** SPDT

**Electrical rating, resistive loads:**

- Open on temperature rise contact (C-1)  
16A 250V, 50 ~60Hz: >100000 cycles,  
20A 250V, 50 ~60Hz: ≥50000 cycles,  
10A 400V, 50 ~60Hz: ≥50000 cycles.

- Close on temperature rise contact (C-2)  
(C-2): 6A 250V 50 ~60Hz: >100000 cycles

**Electrical rating, inductive loads:**

- Open on temperature rise contact (C-1): 6A 250V, 50 ~60Hz: >100000 cycles
- Close on temperature rise contact (C-2): 0.6A 250V 50 ~60Hz: >100000 cycles

**Minimum storage temperature:** -35°C (-30°F)

**Maximum ambient temperature:** 60°C (140°F)

For more technical information ask 8G thermostat technical data sheet



# Pipe mounting thermostats



Because of permanent improvement of our products, drawings, descriptions, features used on these data sheets are for guidance only and can be modified without prior advice

## Main references

Temperature adjustment ranges °C (°F)	Reference with external adjustment	Reference with internal adjustment	Differential °C (°F)	Max. temperature on tube °C (°F)
0-60°C (32-140°F)	Y118G000060AA80J	Y108G000060AA80J	2.5±1°C (4.5±1.8°F)	80°C (176°F)
0-90°C (32-195°F)	Y118G000090AA80J	Y108G000090AA80J	4±3°C (7±5.5°F)	120°C (250°F)
30-90°C (85-195°F)	Y118G030090AA80J	Y108G030090AA80J	4±3°C (7±5.5°F)	120°C (250°F)
30-110°C (85-230°F)	Y118G030110AA80J	Y108G030110AA80J	5±3°C (9±5.5°F)	150°C (300°F)

\*F printing: replace last character (J) by K.

## Knobs printing.

°C Printing			
0-60°C	0-90°C	30-90°C	30-110°C
°F Printing			
32-140°F	32-195°F	85-195°F	90-230°F

# Pipe mounting 3 pole thermostats



Enclosure	Type	Operation	Contact	Measurement	Ranges °C	Models
IP65 IK10	Control	Mechanical	3PST	Pipe		<b>Y118C</b> <b>Y108C</b>
Material						
Aluminum						
Y118C: External adjustment				Y108C: Internal adjustment		

## Applications:

Pipes surface temperature control in usual industrial applications and environments, to control 3 pole heating circuits (No suitable for hazardous areas)

Internal adjustment is convenient for products that must not be frequently adjusted.

**Housing:** Aluminum, IP65, IK10. Grey RAL7032 epoxy painting. Stainless steel captive cover screws. Captive aluminum lid.

**Set point adjustment ranges:** 0-60°C (32-140°F); 0-90°C (32-195°F); 30-90°C (85-195°F); 30-110°C (85-230°F);

**Set point adjustment:** By °C printed knob. All types have an adjustable rotation limit system located inside the knob that allows reducing the set point adjustment span. Types with external adjustment have a transparent window. This device allows seeing the pilot light and the knob position. °F values are available as an option.

**Action:** Temperature control, On-Off action

**Sensing element:** Liquid expansion bulb inside aluminum bracket in contact with the pipe surface.

The bracket design provides optimized thermal contact with 34mm (1", DN25), 60mm (2", DN50) and 90mm (3", DN80) outside diameter tubes. For intermediate sizes, we recommend the use of thermal grease

**Electrical connections:** Inside, on screw terminal connection block

**Earthing:** External screw terminal.

**Cable input and output:** Two M20 cable glands, Black PA66.

**Mounting:** The thermostat housing can be fixed on the pipe by worm drive hose clamps (DIN3017), nylon cable ties (Tie wraps upon EN50146, for applications at permanent temperature lower than 85°C), or specific stainless steel punched band.

**Identification:** Metallic identification label, riveted.

**Contact:** 3PST, open on temperature rise

**Electrical rating, resistive loads:**

16A 250V, 50 ~60Hz: >100000 cycles,

20A 250V, 50 ~60Hz: ≥50000 cycles,

10A 400V, 50 ~60Hz: ≥50000 cycles.

**Minimum storage temperature:** -35°C (-30°F)

**Maximum ambient temperature:** 60°C (140°F)

For more technical information see 8C thermostat technical data sheet.

## Main references

Temperature adjustment ranges °C (°F)	Reference with external adjustment	Reference with internal adjustment	Differential °C (°F)	Max. temperature on tube °C (°F)
0-60°C (32-140°F)	Y118C000060AA80J	Y108C000060AA80J	2.5±1°C (4.5±1.8°F)	80°C (176°F)
0-90°C (32-195°F)	Y118C000090AA80J	Y108C000090AA80J	4±3°C (7±5.5°F)	120°C (250°F)
30-90°C (85-195°F)	Y118C030090AA80J	Y108C030090AA80J	4±3°C (7±5.5°F)	120°C (250°F)
30-110°C (85-230°F)	Y118C030110AA80J	Y108C030110AA80J	5±3°C (9±5.5°F)	150°C (300°F)

\*F printing: replace last character (J) by K

# Pipe mounting 3 pole thermostats



Because of permanent improvement of our products, drawings, descriptions, features used on these data sheets are for guidance only and can be modified without prior advice

## Knobs printing

### °C Printing

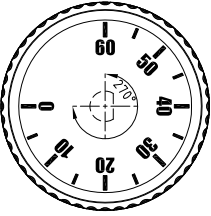
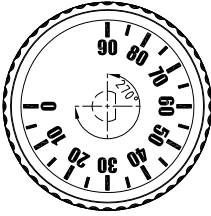
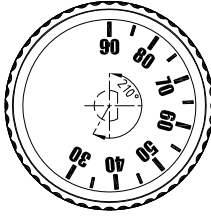
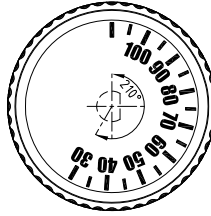
0-60°C	0-90°C	30-90°C	30-110°C
			

### °F Printing

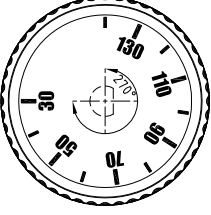
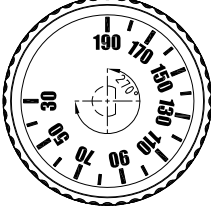
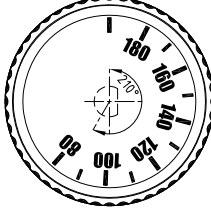
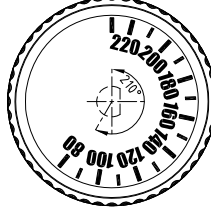
30-140°F	30-195°F	85-195°F	85-230°F
			

# Fixed setting manual reset bulb and capillary limiter



Enclosure	Type	Operation	Contact	Measurement	Ranges °C	Models
IP65 IK10	Manual reset	Mechanical	SPNC	Bulb and Capillary		<b>Y1I8L</b> <b>Y1G8L</b>
Material						
Aluminum						

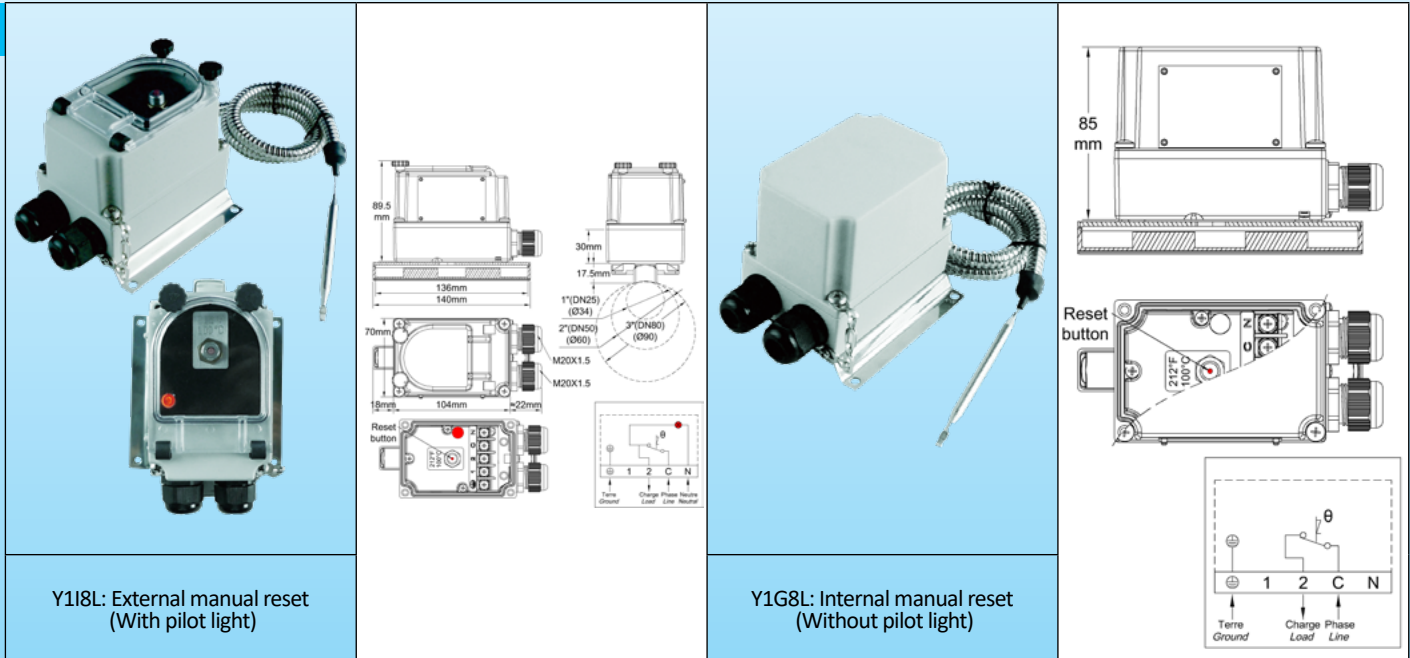

Y1I8L: External manual reset  
(With pilot light)

Y1G8L: Internal manual reset  
(Without pilot light)

## Applications:

- Remote control in usual industrial applications and environments, not hazardous areas, for use as **high limit safety**.
- **Sealed temperature set point**
- Internal reset is convenient for products that must not be frequently reset.

**Housing:** Aluminum, IP65, IK10. Mounted on a SUS304 stainless steel wall mounting plate which keeps the temperature sensing element away from the wall. Grey RAL7032 epoxy painting. Stainless steel captive cover screws. Captive aluminum lid

**Action:** **Fail safe** manual reset high temperature limit.

**Set point calibration value:** 80±8°C (176±15°F), 90±8°C (194±15°F), 110±8°C (230±15°F), 130±8°C (266±15°F), 150±8°C (302±15°F), 175±8°C (347±15°F), 220±11°C (428±20°F), 270±13°C (518±23°F), 300±15°C (572±27°F). Other calibration temperature on request, between 30°C and 320°C (85°F and 610°F)

**Temperature adjustment:** Fixed setting, sealed, no access to user.

**Sensing element:** Liquid expansion bulb and capillary. The capillary is protected by a stainless steel corrugated pipe terminated by a silicone tip. A plastic cap plug provided as standard accessory allows locking the flexible metal conduit inside a pocket. (See pockets in the accessories section)

**Electrical connections:** Inside, on screw terminal connection block. Possibility to connect two wires 1.5mm<sup>2</sup> on each terminal.

**Pilot light:** Allows to visualize limiter contact output position. Standard for all models with transparent window. Non-standard and on special request only for models with plain aluminum cover. (230V, 2 phase power supply, is mandatory for the pilot light)

**Cable input and output:** Two M20 cable glands, Black PA66.

**Earthing:** Internal and external screw terminal.

**Cable output:** M16 cable gland, PA66, for cables up to 10mm dia.

**Mounting:** Wall mounting, by 4 holes for screws dia. 4 to 5mm, 94 × 92mm distance.

**Identification:** Metallic identification label, riveted. Set point calibration is printed in °C and °F beside the manual reset button.

**Contact:** Single pole, open on temperature rise (SPNC)

**Electrical rating:** 16A res. 250/400VAC

- Electrical life **>6,000 cycles**.

**Minimum storage temperature:** -35°C (-30°F)

**Maximum ambient temperature:** 60°C (140°F)

For more technical information ask 8L limiter technical data sheet (catalog 1)

Because of permanent improvement of our products, drawings, descriptions, features used on these data sheets are for guidance only and can be modified without prior advice

# Fixed setting manual reset bulb and capillary limiter



## Main references

Calibration temperature °C (°F)	References with external adjustment	References with internal adjustment	Minimum resettable temperature °C (°F)	Capillary length (C, mm)	Bulb diameter (D, mm)	Bulb length (L, mm)	Max temperature on bulb °C (°F)
80±8°C (176±15°F)	Y1I8L0080105AO6D	Y1G8L0080105AO6D	52°C (126°F)	1500	6	77	105°C (221°F)
90±8°C (194±15°F)	Y1I8L0090115AO6D	Y1G8L0090115AO6D	60°C (140°F)	1500	6	77	115°C (239°F)
110±8°C (230±15°F)	Y1I8L0110135AO6D	Y1G8L0110135AO6D	75°C (167°F)	1500	6	77	135°C (275°F)
130±8°C (266±15°F)	Y1I8L0130155AO6D	Y1G8L0130155AO6D	80°C (176°F)	1500	6	74	155°C (311°F)
150±8°C (302±15°F)	Y1I8L0150175AO6D	Y1G8L0150175AO6D	95°C (203°F)	1500	6	74	175°C (347°F)
175±8°C (347±15°F)	Y1I8L0175200AO4D	Y1G8L0175200AO4D	115°C (239°F)	1500	4	95	200°C (392°F)
220±11°C (428±20°F)	Y1I8L0220245AO4D	Y1G8L0220245AO4D	140°C (284°F)	1500	4	90	245°C (473°F)
270±13°C (518±23°F)	Y1I8L0270295AO4D	Y1G8L0270295AO4D	160°C (320°F)	1500	4	85	295°C (563°F)
300±15°C (572±27°F)	Y1I8L0300325AO4D	Y1G8L0300325AO4D	160°C (320°F)	1500	4	82	325°C (617°F)

Because of permanent improvement of our products, drawings, descriptions, features used on these data sheets are for guidance only and can be modified without prior advice

# Fixed setting manual reset limiter, bulb and capillary



Enclosure	Type	Operation	Contact	Measurement	Ranges °C	Model
IP66 IK10	Manual reset	Mechanical	SPNC	Remote		<b>YF9LNC</b>
Material						
PA66 + PC						

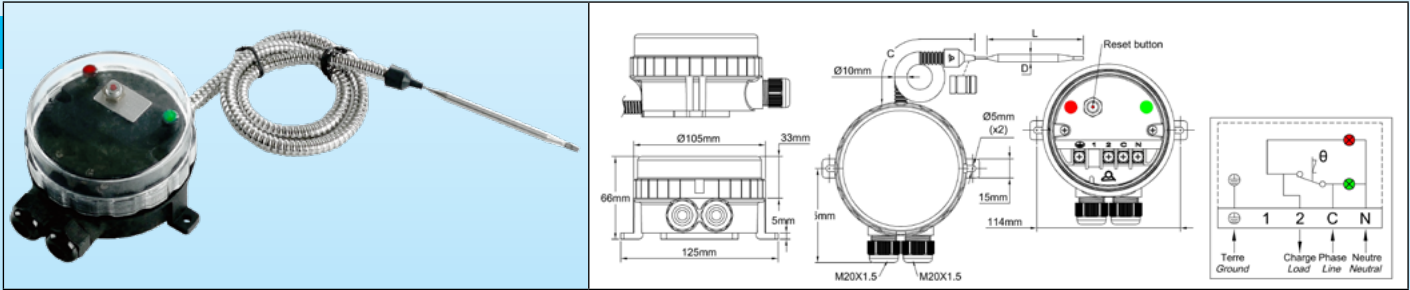

## Applications:

- Equipment requesting a very strong resistance to water ingress. The transparent cover allows to visualize the set point and the 2 pilot lights

Remote control in usual industrial applications and environments, not hazardous areas, for use as high limit safety.

- Sealed temperature set point

**Housing:** Protection class IP 66 upon EN 60529 (waterproof spray water under high pressure and sea splashes, totally dust tight). Body in black PA66, fiber glass reinforced. The transparent polycarbonate cover can be unscrewed by hand, but it is also possible to use a hook spanner. Mechanical impact resistance: IK10. High UV resistance.

**Action:** Fail safe, manual reset high temperature limit.

**Set point calibration value:** 80±8°C (176±15°F), 90±8°C (194±15°F), 110±8°C (230±15°F), 130±8°C (266±15°F), 150±8°C (302±15°F), 175±8°C (347±15°F), 220±11°C (428±20°F), 270±13°C (518±23°F), 300±15°C (572±27°F). Other calibration temperature on request, between 30°C and 320°C (85°F and 610°F).

**Temperature adjustment:** Fixed setting, sealed, no access to user.

**Sensing element:** Liquid expansion bulb and capillary. The capillary is protected by a stainless steel corrugated pipe terminated by a silicone tip. A plastic cap plug provided as standard accessory allows locking the flexible metal conduit inside a pocket (See pockets in the accessories section).

**Pilot lights:** One pilot light visualizes the thermostat contact output position. The other visualizes the power supply input. Phase and neutral electrical supply are mandatory for these pilot lights.

**Cable input and output:** Two M20 cable glands, built-in black PA66.

**Electrical connections:** Inside, on screw terminal connection block. It is possible to connect 2 wires 1.5mm<sup>2</sup> on each terminal.

**Earthing:** Internal screw terminal.

**Mounting:** Wall mounting, by 2 legs with holes for screws dia. 4 to 5mm, 114mm distance

**Identification:** Identification label on backside. Set point calibration is printed in °C and °F beside the manual reset button.

**Contact:** Single pole, open on rise (SPNC)

**Electrical rating:** 16A res. 250/400VAC

-Electrical life >6,000 cycles.

**Minimum storage temperature:** -35°C (-30°F)

**Maximum ambient temperature:** 60°C (140°F)

For more technical information see 8L limiter technical data sheet (catalog 1).

## Main references

Calibration temperature °C (°F)	References	Minimum resettable temperature °C (°F)	Capillary length (C, mm)	Bulb diameter (D, mm)	Bulb length (E, mm)	Max temperature on bulb °C (°F)
80±8°C (176±15°F)	YF9LNC25080156ZD	52°C (126°F)	1500	6	77	105°C (221°F)
90±8°C (194±15°F)	YF9LNC25090156ZD	60°C (140°F)	1500	6	77	115°C (239°F)
110±8°C (230±15°F)	YF9LNC25110156ZD	75°C (167°F)	1500	6	77	135°C (275°F)
130±8°C (266±15°F)	YF9LNC25130156ZD	80°C (176°F)	1500	6	74	155°C (311°F)
150±8°C (302±15°F)	YF9LNC25150156ZD	95°C (203°F)	1500	6	74	175°C (347°F)
175±8°C (347±15°F)	YF9LNC25175156ZD	115°C (239°F)	1500	4	95	200°C (392°F)
220±11°C (428±20°F)	YF9LNC25220156ZD	140°C (284°F)	1500	4	90	245°C (473°F)
270±13°C (518±23°F)	YF9LNC25270156ZD	160°C (320°F)	1500	4	85	295°C (563°F)
300±15°C (572±27°F)	YF9LNC25300156ZD	160°C (320°F)	1500	4	82	325°C (617°F)





# Fixed setting, immersion heater limiter, fail safe

Because of permanent improvement of our products, drawings, descriptions, features used on these data sheets are for guidance only and can be modified without prior advice

Enclosure	Type	Operation	Contact	Measurement	Ranges °C	Model
IP66 IK10	Manual reset	Mechanical	SPNC	Immersion heater		<b>YF8LNC</b>
Material						
PA66 + PC						

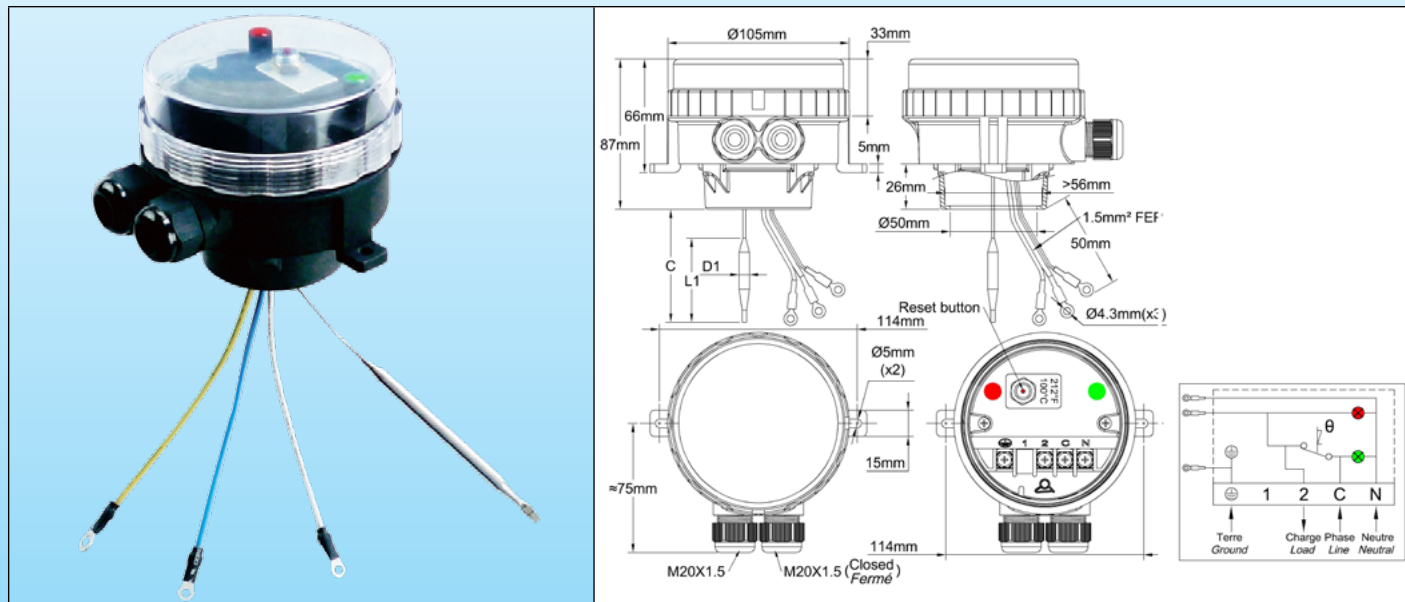

## Applications:

- **Equipment requesting a very strong resistance to water ingress. The transparent cover allows to visualize the set point and the 2 pilot lights.**

Fully wired sub assembly for use as **high limit** on immersion heater elements, 1"1/2 or M45x2 with double thread or rotation ring.

Applications in usual industrial applications and environments, non-hazardous areas.

**Housing:** Protection class IP 66 upon EN 60529 (waterproof spray water under high pressure and sea splashes, totally dust tight). Body in black PA66, fiber glass reinforced. The transparent polycarbonate cover can be unscrewed by hand, but it is also possible to use a hook spanner. A removable adapter is screwed at the bottom of the enclosure. It fits the usual immersion heater fittings. Mechanical impact resistance: IK10. High UV resistance..

**Set point adjustment:** Factory set. Not adjustable by user

**Action:** Manual reset limiter, fail safe

**Sensing element:** Liquid expansion bulb and capillary. The bulb and the capillary go out by the bottom of the enclosure to fit in the heater pocket.

**Pilot lights:** One pilot light visualizes the thermostat contact output position. The other visualizes the power supply input. Phase and neutral electrical supply are mandatory for these pilot lights.

**Set point adjustment values:** 80±8°C (176±15°F), 90±8°C (194±15°F), 110±8°C (230±15°F). Other values can be set between 30°C and 110°C (85°F and 230°F)

**Cable input and output:** Two M20 cable glands, built-in black PA66. One of them is closed.

**Electrical connections:** Inside, on screw terminal connection block. It is possible to connect 2 wires 1.5mm<sup>2</sup> on each terminal.

**Earthing:** Internal screw terminal and wire with round hole terminal for the immersion heater.

**Mounting:** By the immersion heater thread or by 2 legs with holes for screws dia. 4 to 5mm, 114mm distance.

**Identification:** Identification label on backside. Set point calibration is printed in °C and °F beside the manual reset button.

**Contact:** Single pole, open on rise (SPNC)

**Electrical rating:** 16A res. 250/400VAC

- Electrical life >6.000 cycles.

**Minimum storage temperature:** -35°C (-30°F)

**Maximum ambient temperature:** 60°C (140°F)

For more technical information see 8L limiter technical data sheet



## Main references

Calibration temperature °C (°F)	References	Capillary length (C, mm)	Bulb diameter (D1, mm)	Bulb length (L1, mm)	Minimum resettable temperature °C (°F)	Max temperature on bulb °C (°F)
80±8°C (176±15°F)	YF8LNC25080026ZJ	200	6	86±5	52°C (126°F)	105°C (220°F)
80±8°C (176±15°F)	YF8LNC25080036ZJ	300	6	86±5	52°C (126°F)	105°C (220°F)
80±8°C (176±15°F)	YF8LNC25080046ZJ	400	6	86±5	52°C (126°F)	105°C (220°F)
80±8°C (176±15°F)	YF8LNC25080056ZJ	500	6	86±5	52°C (126°F)	105°C (220°F)
90±8°C (194±15°F)	YF8LNC25090026ZJ	200	6	98±5	60°C (140°F)	115°C (240°F)
90±8°C (194±15°F)	YF8LNC25090036ZJ	300	6	98±5	60°C (140°F)	115°C (240°F)
90±8°C (194±15°F)	YF8LNC25090046ZJ	400	6	98±5	60°C (140°F)	115°C (240°F)
90±8°C (194±15°F)	YF8LNC25090056ZJ	500	6	98±5	60°C (140°F)	115°C (240°F)
110±8°C (230±15°F)	YF8LNC25110026ZJ	200	6	98±5	75°C (167°F)	135°C (275°F)
110±8°C (230±15°F)	YF8GNC251100036ZJ	300	6	98±5	75°C (167°F)	135°C (275°F)
110±8°C (230±15°F)	YF8GNC25110046ZJ	400	6	98±5	75°C (167°F)	135°C (275°F)
110±8°C (230±15°F)	YF8GNC25110056ZJ	500	6	98±5	75°C (167°F)	135°C (275°F)

Because of permanent improvement of our products, drawings, descriptions, features used on these data sheets are for guidance only and can be modified without prior advice



# Mechanical thermostats for surfaces measurement



Because of permanent improvement of our products, drawings, descriptions, features used on these data sheets are for guidance only and can be modified without prior advice



Because of permanent improvement of our products, drawings, descriptions, features used on these data sheets are for guidance only and can be modified without prior advice

# Thermostat with external knob adjustment, IP65, with two pilot lights, for industrial jacket and blanket heaters.

## Type Y2U

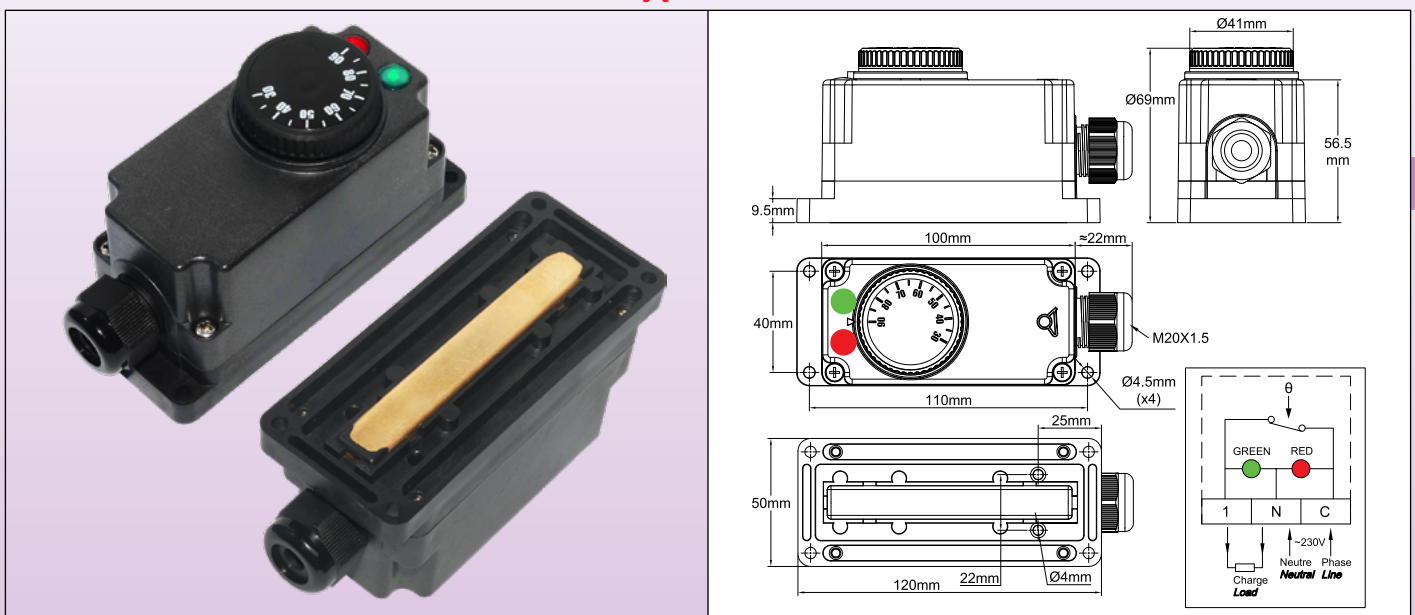

### Applications

Developed for industrial applications in electric blankets, heating belts, jacket heaters, this thermostat is equipped with a flat sensitive part allowing to put it in contact with a surface, 4 holes allowing to mount it on this surface, and a direct passage between the connection terminal block and the back of the housing, for the passage of wires to the heating element.

### Main Features

- Housing:** IP65, 120 × 50 × 69 mm, fiberglass reinforced PA66, UL94V0. High impact and UV resistance, with silicone waterproof gasket on thermostat shaft.
- Electrical input:** ISO M20 cable gland, Black PA66, IP67, for cables from 6 to 12 mm dia.
- Electrical output:** 2 dia.4 mm holes, located on the backside face, allow to introduce the heating element wires directly inside the housing. If IP65 ingress protection is requested on the backside, these 2 holes must be sealed around the wires with RTV silicone.
- Temperature adjustment:** By temperature printed knob.
- Sensing element:** Liquid filled bulb, located inside the brass cap.
- Adjustment ranges:** 30-90°C (85-195°F), 30-110°C (85-230°F).
- Pilot lights:** Allow to visualize the power supply and thermostat contact position.
- Electrical connections:** Inside, on 2.5mm<sup>2</sup> screw terminals connection block.
- Mounting:** By 4 holes for screws dia. 4mm, 40 × 110 mm distance.
- Electrical rating:** Open on temperature rise contact (C-1), 16A (2.6) 250VAC, >100.000 cycles.
- Minimum Storage temperature:** -35°C (-30°F)
- Maximum ambient temperature:** 110°C (230°F)

### Main part numbers

Part numbers with knobs printed in °C	Part numbers with knobs printed in °F	Temperature adjustment range °C (°F)	Differential °C (°F)
Y2U8GB030090AA66	Y2U8GB030090AA67	30-90°C (85-195°F)	4±3°C (7±5.5 °F)
Y2U8GB030110AA66	Y2U8GB030110AZ67	30-110°C (85-230°F)	5±3°C (9±5.5 °F)



Because of permanent improvement of our products, drawings, descriptions, features used on these data sheets are for guidance only and can be modified without prior advice

# Thermostat with internal adjustment, IP65, with two pilot lights, for surface mounting on industrial jacket heaters, blanket heaters and silicone heaters

Enclosure	Type	Operation	Contact	Measurement	Ranges °C	Type
IP65	Control	Mechanical	SPNC	Surface mounting		Y2W
Material						
PA66						

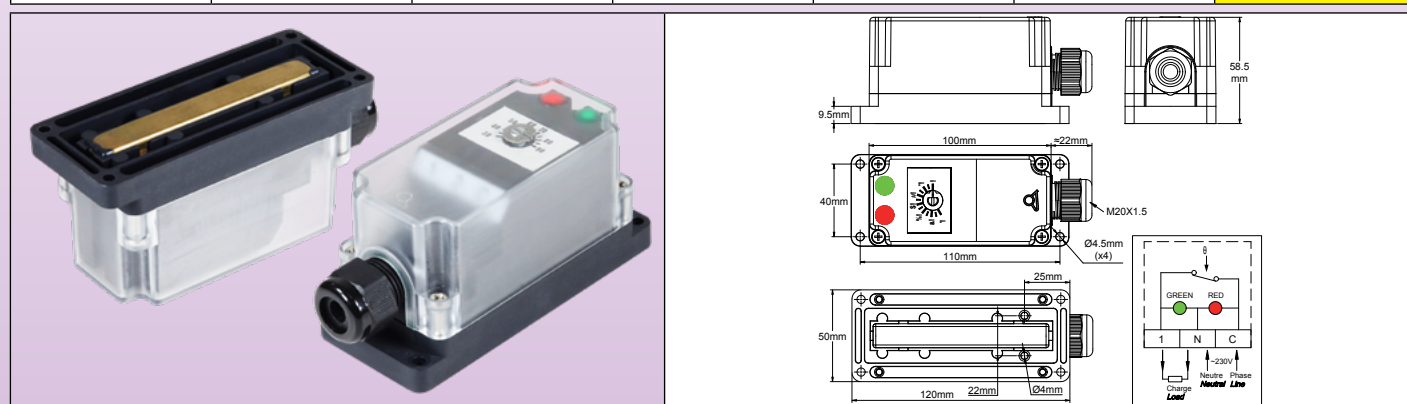

## Applications

Developed for industrial applications in electric blankets, heating belts, jacket heaters, silicone heaters this thermostat is equipped with a flat sensitive part allowing to put it in contact with a surface, 4 holes allowing to mount it on this surface, and a direct passage between the connection terminal block and the back of the housing, for the passage of wires to the heating element.

## Main Features

**Housing:** IP65, 120 × 50 × 58.5 mm, fiberglass reinforced PA66, UL94V0. High impact and UV resistance, with transparent cover in polycarbonate

**Electrical input:** ISO M20 cable gland, Black PA66, IP67, for cables from 6 to 12 mm dia.

**Electrical output:** 2 dia.4 mm holes, located on the backside face, allow to introduce the heating element wires directly inside the housing. If IP65 ingress protection is requested on the backside, these 2 holes must be sealed around the wires with RTV silicone.

**Temperature adjustment:** By temperature printed dial.

**Sensing element:** Liquid filled bulb, located inside the brass cap.

**Adjustment ranges:** 30-90°C (85-195°F), 30-110°C (85-230°F).

**Pilot lights:** Allow to visualize the power supply and thermostat contact position.

**Electrical connections:** Inside, on 2.5mm<sup>2</sup> screw terminals connection block.

**Mounting:** By 4 holes for screws dia. 4mm, 40 × 110 mm distance.

**Electrical rating:** Open on temperature rise contact (C-1), 16A (2.6) 250VAC, >100.000 cycles.

**Minimum Storage temperature:** -35°C (-30°F)

**Maximum ambient temperature:** 110°C (230°F)

## Main part numbers

Part numbers with dial printed in °C	Part numbers with dial printed in °F	Temperature adjustment range °C (°F)	Differential °C (°F)
Y2W8GB030090AA66	Y2W8GB030090AA67	30-90°C (85-195°F)	4±3°C(7±5.5 °F)
Y2W8GB030110AA66	Y2W8GB030110AZ67	30-110°C (85-230°F)	5±3°C (9±5.5 °F)





# Mechanical temperature limiters, with rod or pipe mounting



Because of permanent improvement of our products, drawings, descriptions, features used on these data sheets are for guidance only and can be modified without prior advice

# Fixed setting manual reset limiter, rod



Because of permanent improvement of our products, drawings, descriptions, features used on these data sheets are for guidance only and can be modified without prior advice

Enclosure	Type	Operation	Contact	Measurement	Ranges °C	Models
IP65 IK10	Manual reset	Mechanical	SPNC	Rod		<b>Y1S8L</b> <b>Y1R8L</b>
Material						
Aluminum						

<p><b>Y1S8L: External manual reset (With pilot light)</b></p>		<p><b>Y1R8L: Internal manual reset (Without pilot light)</b></p>	
---	--	--	--

## Applications:

These **liquid expansion** rod manual reset limiters can be installed inside pockets as immersion thermostats in pipelines and containers, and as **high limit safety** in air ducts, in usual industrial applications and environments. (Not suitable for hazardous areas).

- Internal reset is convenient for products that must not be frequently reset.
- Insensibility to strong vibrations
- **Sealed calibration point, not adjustable.**

**Housing:** Aluminum, IP65, IK10. Grey RAL7032 epoxy painting. Stainless steel captive cover screws. Captive aluminum lid

**Action:** **fail safe** manual reset high temperature limit.

**Set point calibration value:** 80±8°C (176±15°F), 90±8°C (194±15°F), 110±8°C (230±15°F), 130±8°C (266±15°F), 150±8°C (302±15°F), 175±8°C (347±15°F), 220±11°C (428±20°F), 270±13°C (518±23°F), 300±15°C (572±27°F). Other calibration temperature on request, between 30°C and 320°C (85°F and 610°F)

**Temperature adjustment:** fixed setting, sealed, no access to user.

**Sensing element:** Liquid expansion bulb and capillary. The capillary is protected by a stainless steel corrugated pipe terminated by a silicone tip. A plastic cap plug provided as standard accessory allows locking the flexible metal conduit inside a pocket (See pockets in the accessories section)

**Sensing element:** Liquid expansion rod. This rod has a non-temperature sensing zone named dead zone which allows thermal insulation crossing. An increased diameter under the thermostat head allows mounting pockets, coolers or brackets (See pockets in the accessories section)

**Electrical connections:** Inside, on screw terminal connection block. Possibility to connect two wires 1.5mm<sup>2</sup> on each terminal.

**Pilot light:** Allows to visualize limiter contact output position. Standard for all models with transparent window.

Non-standard and on special request only for models with plain aluminum cover. (230V, 2 phases power supply, is mandatory for the pilot light)

**Cable input and output:** Two M20 cable glands, Black PA66.

**Earthing:** Internal and external screw terminal.

**Cable output:** M16 cable gland, PA66, for cables up to 10mm dia.

**Identification:** Metallic identification label, riveted. Set point calibration is printed in °C and °F beside the manual reset button.

**Contact:** Single pole, open on temperature rise (SPNC)

**Electrical rating:** 16A res. 250/400VAC

- Electrical life > **6,000 cycles.**

**Minimum storage temperature:** -35°C (-30°F)

**Maximum ambient temperature:** 60°C (140°F)

For more technical information see 8L limiter technical data sheet

# Fixed setting manual reset limiter, rod



## Main references

Calibration temperature °C (°F)	References with external adjustment	References with internal adjustment	Minimum resettable temperature °C (°F)	Rod length* (L, mm)	Rod diameter (D, mm)	Temperature sensing length (mm)	Max temperature on bulb °C (°F)
80±8°C (176±15°F)	Y1S8L0080105117D	Y1R8L0080105117D	52°C (126°F)	170	10	87	105°C (221°F)
80±8°C (176±15°F)	Y1S8L0080105123D	Y1R8L0080105123D	52°C (126°F)	230	10	87	105°C (221°F)
80±8°C (176±15°F)	Y1S8L0080105130D	Y1R8L0080105130D	52°C (126°F)	300	10	87	105°C (221°F)
80±8°C (176±15°F)	Y1S8L0080105145D	Y1R8L0080105145D	52°C (126°F)	450	10	87	105°C (221°F)
80±8°C (176±15°F)	Y1S8L0080105160D	Y1R8L0080105160D	52°C (126°F)	600	10	87	105°C (221°F)
80±8°C (176±15°F)	Y1S8L0080105180D	Y1R8L0080105180D	52°C (126°F)	800	10	87	105°C (221°F)
90±8°C (194±15°F)	Y1S8L0090115117D	Y1R8L0090115117D	60°C (140°F)	170	10	87	115°C (239°F)
90±8°C (194±15°F)	Y1S8L0090115123D	Y1R8L0090115123D	60°C (140°F)	230	10	87	115°C (239°F)
90±8°C (194±15°F)	Y1S8L0090115130D	Y1R8L0090115130D	60°C (140°F)	300	10	87	115°C (239°F)
90±8°C (194±15°F)	Y1S8L0090115145D	Y1R8L0090115145D	60°C (140°F)	450	10	87	115°C (239°F)
90±8°C (194±15°F)	Y1S8L0090115160D	Y1R8L0090115160D	60°C (140°F)	600	10	87	115°C (239°F)
90±8°C (194±15°F)	Y1S8L0090115180D	Y1R8L0090115180D	60°C (140°F)	800	10	87	115°C (239°F)
110±8°C (230±15°F)	Y1S8L0110135117D	Y1R8L0110135117D	75°C (167°F)	170	10	87	135°C (275°F)
110±8°C (230±15°F)	Y1S8L0110135123D	Y1R8L0110135123D	75°C (167°F)	230	10	87	135°C (275°F)
110±8°C (230±15°F)	Y1S8L0110135130D	Y1R8L0110135130D	75°C (167°F)	300	10	87	135°C (275°F)
110±8°C (230±15°F)	Y1S8L0110135145D	Y1R8L0110135145D	75°C (167°F)	450	10	87	135°C (275°F)
110±8°C (230±15°F)	Y1S8L0110135160D	Y1R8L0110135160D	75°C (167°F)	600	10	87	135°C (275°F)
110±8°C (230±15°F)	Y1S8L0110135180D	Y1R8L0110135180D	75°C (167°F)	800	10	87	135°C (275°F)
130±8°C (266±15°F)	Y1S8L0130155117D	Y1R8L0130155117D	80°C (176°F)	170	10	87	155°C (311°F)
130±8°C (266±15°F)	Y1S8L0130155123D	Y1R8L0130155123D	80°C (176°F)	230	10	87	155°C (311°F)
130±8°C (266±15°F)	Y1S8L0130155130D	Y1R8L0130155130D	80°C (176°F)	300	10	87	155°C (311°F)
130±8°C (266±15°F)	Y1S8L0130155145D	Y1R8L0130155145D	80°C (176°F)	450	10	87	155°C (311°F)
130±8°C (266±15°F)	Y1S8L0130155160D	Y1R8L0130155160D	80°C (176°F)	600	10	87	155°C (311°F)
130±8°C (266±15°F)	Y1S8L0130155180D	Y1R8L0130155180D	80°C (176°F)	800	10	87	155°C (311°F)
150±8°C (302±15°F)	Y1S8L0150175123D	Y1R8L0150175123D	95°C (203°F)	230	10	87	175°C (347°F)
150±8°C (302±15°F)	Y1S8L0150175130D	Y1R8L0150175130D	95°C (203°F)	300	10	87	175°C (347°F)
150±8°C (302±15°F)	Y1S8L0150175145D	Y1R8L0150175145D	95°C (203°F)	450	10	87	175°C (347°F)
150±8°C (302±15°F)	Y1S8L0150175160D	Y1R8L0150175160D	95°C (203°F)	600	10	87	175°C (347°F)
150±8°C (302±15°F)	Y1S8L0150175180D	Y1R8L0150175180D	95°C (203°F)	800	10	87	175°C (347°F)
175±8°C (347±15°F)	Y1S8L0175200123D	Y1R8L0175200123D	115°C (239°F)	230	10	59	200°C (392°F)
175±8°C (347±15°F)	Y1S8L0175200130D	Y1R8L0175200130D	115°C (239°F)	300	10	59	200°C (392°F)
175±8°C (347±15°F)	Y1S8L0175200145D	Y1R8L0175200145D	115°C (239°F)	450	10	59	200°C (392°F)
175±8°C (347±15°F)	Y1S8L0175200160D	Y1R8L0175200160D	115°C (239°F)	600	10	59	200°C (392°F)
175±8°C (347±15°F)	Y1S8L0175200180D	Y1R8L0175200180D	115°C (239°F)	800	10	59	200°C (392°F)
*220±11°C (428±20°F)	Y1S8L0220245830D	Y1R8L0220245830D	140°C (284°F)	300	8	59	245°C (473°F)
*220±11°C (428±20°F)	Y1S8L0220245845D	Y1R8L0220245845D	140°C (284°F)	450	8	59	245°C (473°F)
*220±11°C (428±20°F)	Y1S8L0220245860D	Y1R8L0220245860D	140°C (284°F)	600	8	59	245°C (473°F)
*220±11°C (428±20°F)	Y1S8L0220245880D	Y1R8L0220245880D	140°C (284°F)	800	8	59	245°C (473°F)
*270±13°C (518±23°F)	Y1S8L0270295830D	Y1R8L0270295830D	160°C (320°F)	300	8	165	295°C (563°F)
*270±13°C (518±23°F)	Y1S8L0270295845D	Y1R8L0270295845D	160°C (320°F)	450	8	165	295°C (563°F)
*270±13°C (518±23°F)	Y1S8L0270295860D	Y1R8L0270295860D	160°C (320°F)	600	8	165	295°C (563°F)
*270±13°C (518±23°F)	Y1S8L0270295880D	Y1R8L0270295880D	160°C (320°F)	800	8	165	295°C (563°F)
*300±15°C (572±27°F)	Y1S8L0300325830D	Y1R8L0300325830D	160°C (320°F)	300	8	165	325°C (617°F)
*300±15°C (572±27°F)	Y1S8L0300325845D	Y1R8L0300325845D	160°C (320°F)	450	8	165	325°C (617°F)
*300±15°C (572±27°F)	Y1S8L0300325860D	Y1R8L0300325860D	160°C (320°F)	600	8	165	325°C (617°F)
*300±15°C (572±27°F)	Y1S8L0300325880D	Y1R8L0300325880D	160°C (320°F)	800	8	165	325°C (617°F)

\* Above 200°C we recommend to use a rod cooler reference 66RF07015 or 66RF0701F12 between the rod and the enclosure (see accessories).  
Caution: This cooler reduces the usable rod length by 70mm

Because of permanent improvement of our products, drawings, descriptions, features used on these data sheets are for guidance only and can be modified without prior advice



# The Y1 range of thermostats with IP65 enclosures

Because of permanent improvement of our products, drawings, descriptions, features used on these data sheets are for guidance only and can be modified without prior advice

Type	Set point adjustment	Manual reset access	Contact	Measurement	Ranges °C	Model
<b>Manual reset</b> 	<b>Interne</b> 	<b>Screwed cap</b> 	<b>Single pole</b> 	<b>Rod</b> 		<b>Y1Y</b> <b>Adjustable limiter</b> <b>1X</b>

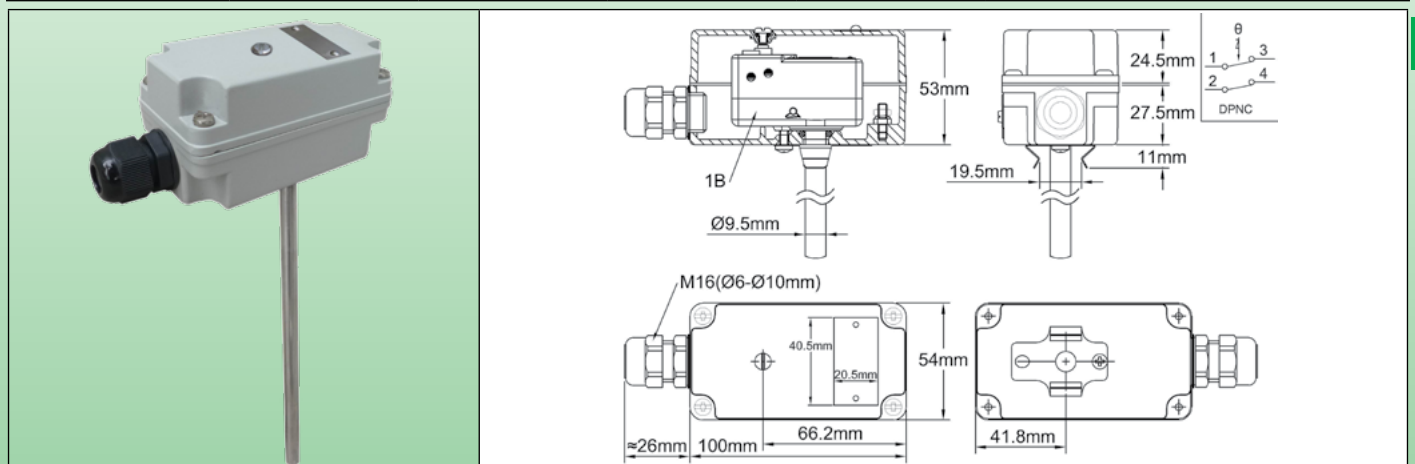

## Applications:

- **Changeover contact for switch off remote signaling**
  - **Small footprint enclosure**
  - **Internal adjustment is convenient for products that must not be frequently adjusted.**
  - **Manual reset with internal access under M4 screwed cap allows to reset without need to open the enclosure.**
  - **Short response time**
  - **Low sensibility to strong vibrations**
- Long electrical and mechanical life model*
- Housing:** Aluminum, IP65, IK10, 100 × 53 × 54mm. Grey RAL7032 epoxy painting
- Set point adjustment ranges:** -10+130°C (+14+264°F), +15+95 °C (+59+203°F), +25+165°C (+77+329°F).
- Temperature adjustment:** Set point adjustable by **arrow style knob, on °C printed dial**. Consult us for °F versions
- Action:** High limit with manual reset and adjustable set point
- Sensing element:** Bimetal rod, stainless steel-Invar. A clip under the thermostat head allows mounting pockets or brackets (See pockets in the accessories section)
- Electrical connections:** on thermostat screw terminals
- Earthing:** on internal screw terminal
- Cable output:** M16 cable gland, PA66, for cables up to 10mm dia.
- Mounting:** on pockets for liquid immersion or flange for air ducts
- Identification:** 20 × 40mm stainless steel identification label, riveted.
- Contact:** SPDT
- Electrical rating:** 15A (4)A 250V/400VAC. Res.  
Electrical life >**100,000 cycles**.
- Storage minimum temperature:** -50°C (-60°F)

## Main references

Temperature range °C (°F)	Rod length (mm)	Reference with standard differential	Min reset differential value °C (°F)	Max. temperature on rod °C (°F)
-10+130°C (+14+264°F)	200	Y1Y1XA-10130B20L	20°C (36°F)	180°C (356°F)
+15+95°C (+59+203°F)	200	Y1Y1XA015095B20L	20°C (36°F)	145°C (293°F)
+15+95°C (+59+203°F)	300	Y1Y1XA015095B30L	15°C (27°F)	145°C (293°F)
+25+165°C (+77+329°F)	200	Y1X1XA025165B20L	20°C (36°F)	215°C (419°F)

# The Y1 range of thermostats with IP65 enclosures



Type	Set point adjustment	Manual reset access	Contact	Measurement	Ranges °C	Model
Manual reset 	Interne 	Screwed cap 	Double pole 	Rod 		<b>Y1Y</b> <b>Adjustable limiter</b> <b>1D</b>

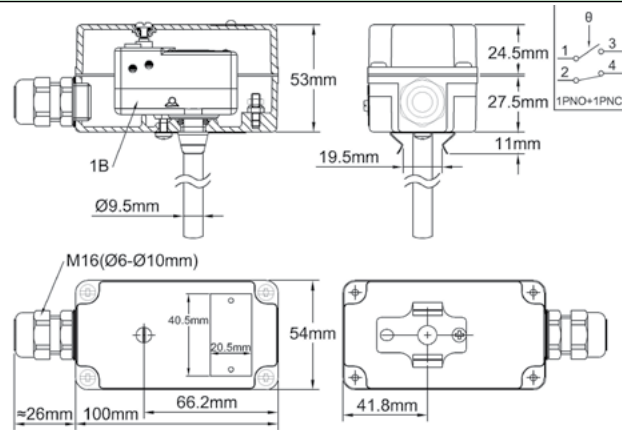
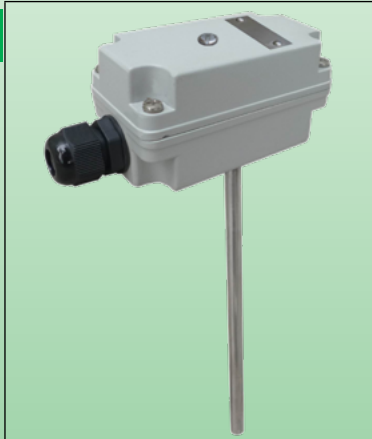

## Applications:

### - Double pole contact for 2 phases switch off

These **bimetal** rod thermostats can be installed inside pockets as immersion thermostats in pipelines and containers, and for use as **high limit safety**, in air ducts, in usual industrial application and environment. (Not suitable for hazardous areas).

### - Small footprint enclosure

### - Internal adjustment is convenient for products that must not be frequently adjusted.

### - Manual reset with internal access under M4 screwed cap allows to reset without need to open the enclosure.

### - Short response time

### - Low sensibility to strong vibrations

*Long electrical and mechanical life model*

**Housing:** Aluminum, IP65, IK10, 100 × 53 × 54mm. Grey RAL7032 epoxy painting

**Set point adjustment ranges:** **-10+130°C (+14+264°F), +15+95 °C (+59+203°F), +25+165°C (+77+329°F).**

**Temperature adjustment:** Set point adjustable by **arrow style knob, on °C printed dial**. Consult us for °F versions

**Action:** High limit with manual reset and adjustable set point

**Sensing element:** Bimetal rod, stainless steel-Invar. A clips under the thermostat head allows mounting pockets or brackets (See pockets in the accessories section)

**Electrical connections:** on thermostat screw terminals

**Earthing:** on internal screw terminal

**Cable output:** M16 cable gland, PA66, for cables up to 10mm dia.

**Mounting:** on pockets for liquid immersion or flange for air ducts

**Identification:** 20 × 40mm stainless steel identification label, riveted.

**Contact:** DPST, open on temperature rise

**Electrical rating:** 15A (4)A 250V/400VAC. Res.

Electrical life > **100,000 cycles.**

**Storage minimum temperature:** -50°C (-60°F)

## Main references

Temperature range °C (°F)	Rod length (mm)	Reference with standard differential	Min reset differential value °C (°F)	Max. temperature on rod °C (°F)
-10+130°C (+14+264°F)	200	Y1Y1DA-10130B20L	20°C (36°F)	180°C (356°F)
+15+95°C (+59+203°F)	200	Y1Y1DA015095B20L	20°C (36°F)	145°C (293°F)
+15+95°C (+59+203°F)	300	Y1Y1DA015095B30L	15°C (27°F)	145°C (293°F)
+25+165°C (+77+329°F)	200	Y1Y1DA025165B20L	20°C (36°F)	215°C (419°F)





# Fixed setting manual reset limiter, pipe mounting

Enclosure	Type	Operation	Contact	Measurement	Ranges °C	Models
IP65 IK10	Control	Mechanical	SPNC	Pipe		<b>Y118L</b> <b>Y108L</b>
Material						
Aluminum						

<p><b>Y118L: External manual reset (With pilot light)</b></p>		<p><b>Y108L: Internal manual reset (Without pilot light)</b></p>	
---	--	--	--

## Applications:

These **liquid expansion** pipe surface manual reset limiters can be installed inside pockets as immersion thermostats in pipelines and containers, and as **high limit safety** in air ducts, in usual industrial applications and environments. (Not suitable for hazardous areas).

- **Internal adjustment is convenient for products that must not be frequently adjusted.**
- **Insensibility to strong vibrations**
- **Sealed calibration point, not adjustable**

**Housing:** Aluminum, IP65, IK10. Grey RAL7032 epoxy painting. Stainless steel captive cover screws. Captive aluminum lid.

**Action:** **fail safe** manual reset high temperature limit.

**Set point calibration value:** 80±8°C (176±15°F), 90±8°C (194±15°F), 110±8°C (230±15°F). Other calibration temperature on request, between 30°C and 110°C (85°F and 230°F).

**Temperature adjustment:** fixed setting, sealed, no access to user.

**Sensing element:** Liquid expansion bulb inside aluminum bracket in contact with the pipe surface.

The bracket design provides optimized thermal contact with 34mm (1", DN25), 60mm (2", DN50) and 90mm (3", DN80) outside diameter tubes. For intermediate sizes, we recommend the use of thermal grease.

**Electrical connections:** Inside, on screw terminal connection block

**Earthing:** Internal and external screw terminal. (Possibility to connect 2 wires 1.5mm<sup>2</sup> on each terminal)

**Pilot light:** Allow to visualize thermostat contact output position. Standard for all models with transparent window. Non Standard and on special request only for models with plain aluminum cover.

**Cable input and output:** Two M20 cable glands, Black PA66.

**Mounting:** The thermostat housing can be fixed on the pipe by worm drive hose clamps (DIN3017), nylon cable ties (Tie wraps upon EN50146, for applications at permanent temperature lower than 85°C), or specific stainless steel punched band.

**Identification:** Metallic identification label, riveted. Set point calibration is printed in °C and °F beside the manual reset button.

**Contact:** Single pole, open on rise (SPNC)

**Electrical rating:** 16A res. 250/400VAC

- Electrical life **>6,000 cycles.**

**Minimum storage temperature:** -35°C (-30°F)

**Maximum ambient temperature:** 60°C (140°F)

For more technical information see 8L limiter technical data sheet.

## Main references

Calibration temperature °C (°F)	References with external adjustment	References with internal adjustment	Minimum resettable temperature °C (°F)	Max temperature on pipe °C (°F)
80±8°C (176±15°F)	Y118L080105AA80D	Y108L080105A80D	52°C (126°F)	105°C (221°F)
90±8°C (194±15°F)	Y118L090115AA80D	Y108L090115A80D	60°C (140°F)	115°C (239°F)
110±8°C (230±15°F)	Y118L110135AA80D	Y108L110135A80D	75°C (167°F)	135°C (275°F)

# Fixed setting manual reset limiter, rod



Enclosure	Type	Operation	Contact	Measurement	Ranges °C	Model
IP66 IK10	Manual reset	Mechanical	SPNC	Rod		<b>YF4LNC</b>
Material						
PA66 & PC						

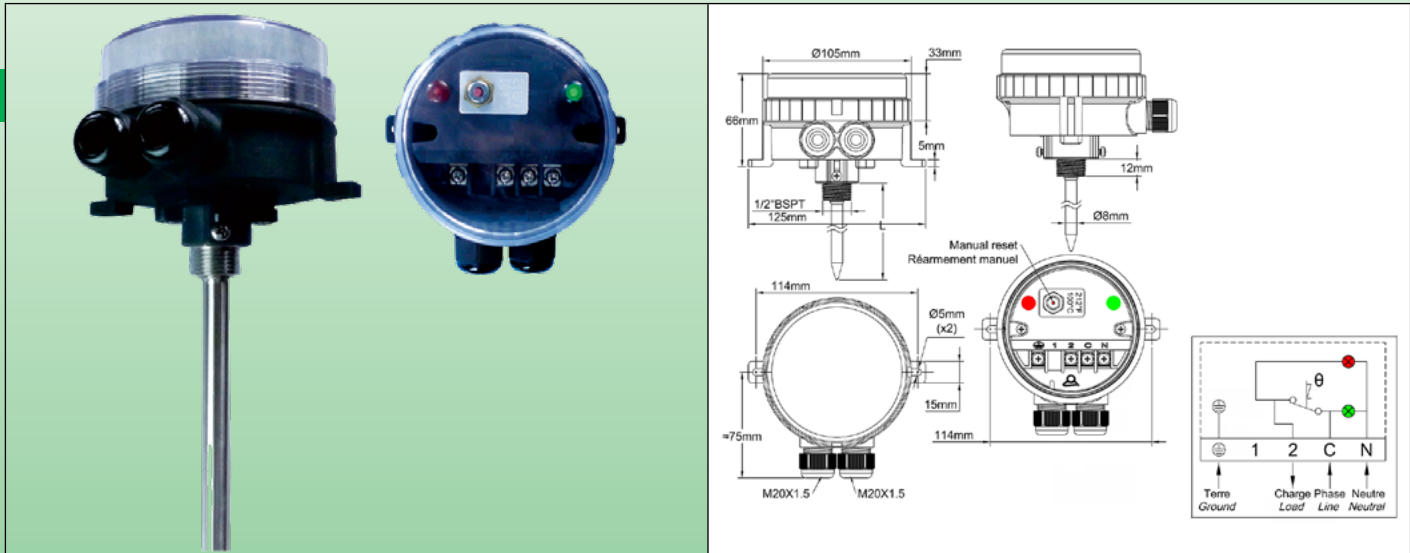

## Applications:

- Equipment requesting a very strong resistance to water ingress. The transparent cover allows to visualize the set point and the 2 pilot lights

These liquid expansion rod manual reset limiter can be installed inside pockets as immersion thermostats in pipelines and containers, and as high limit safety in air ducts, in usual industrial applications and environments. (Not suitable for hazardous areas).

- Sealed temperature set point.

**Housing:** Protection class IP 66 upon EN 60529 (waterproof spray water under high pressure and sea splashes, totally dust tight). Body in black PA66, fiber glass reinforced. The transparent polycarbonate cover can be unscrewed by hand, but it is also possible to use a hook spanner. Mechanical impact resistance: IK10. High UV resistance.

**Action:** Fail safe manual reset high temperature limit.

**Set point calibration value:** 80±8°C (176±15°F), 90±8°C (194±15°F), 110±8°C (230±15°F). Other calibration temperature on request, between 30°C and 320°C (85°F and 230°F).

**Temperature adjustment:** Fixed setting, sealed, no access to user.

**Sensing element:** Liquid expansion bulb and capillary inside nickel plated brass pocket. Thread ½" BSPT. Tube outside diameter 6mm. Located at the bottom of the housing, 2 screws are used to secure standard pockets.

**Pilot lights:** One pilot light visualizes the thermostat contact output position. The other visualizes the power supply input. Phase and line electrical supply is mandatory for these pilot lights.

**Cable input and output:** Two M20 cable glands, built-in black PA66.

**Electrical connections:** Inside, on screw terminal connection block. It is possible to connect 2 wires 1.5mm<sup>2</sup> on each terminal.

**Earthing:** Internal screw terminal.

**Mounting:** By the pocket thread or by 2 legs with holes for screws dia. 4 to 5mm, 114mm distance.

**Identification:** Identification label on backside. Set point calibration is printed in °C and °F beside the manual reset button.

**Contact:** Single pole, open on rise (SPNC)

**Electrical rating:** 16A res. 250/400VAC

- Electrical life >6,000 cycles.

**Minimum storage temperature:** -35°C (-30°F)

**Maximum ambient temperature:** 60°C (140°F)

For more technical information see 8L limiter technical data sheet (catalog 1).

# Fixed setting manual reset limiter, rod



## Main references

Calibration temperature °C (°F)	References	Minimum resettable temperature °C (°F)	Pocket length (L, mm)	Temperature sensing length (mm)	Max temperature on rod °C (°F)
80±8°C (176±15°F)	YF4LNC25080823UD	52°C (126°F)	230	87	105°C (221°F)
80±8°C (176±15°F)	YF4LNC25080830UD	52°C (126°F)	300	87	105°C (221°F)
80±8°C (176±15°F)	YF4LNC25080845UD	52°C (126°F)	450	87	105°C (221°F)
80±8°C (176±15°F)	YF4LNC25080860UD	52°C (126°F)	600	87	105°C (221°F)
90±8°C (194±15°F)	YF4LNC25090823UD	60°C (140°F)	230	87	115°C (239°F)
90±8°C (194±15°F)	YF4LNC25090830UD	60°C (140°F)	300	87	115°C (239°F)
90±8°C (194±15°F)	YF4LNC25090845UD	60°C (140°F)	450	87	115°C (239°F)
90±8°C (194±15°F)	YF4LNC25090860UD	60°C (140°F)	600	87	115°C (239°F)
110±8°C (230±15°F)	YF4LNC25110823UD	75°C (167°F)	230	87	135°C (275°F)
110±8°C (230±15°F)	YF4LNC25110830UD	75°C (167°F)	300	87	135°C (275°F)
110±8°C (230±15°F)	YF4LNC25110845UD	75°C (167°F)	450	87	135°C (275°F)
110±8°C (230±15°F)	YF4LNC25110860UD	75°C (167°F)	600	87	135°C (275°F)

Because of permanent improvement of our products, drawings, descriptions, features used on these data sheets are for guidance only and can be modified without prior advice



Because of permanent improvement of our products, drawings, descriptions, features used on these data sheets are for guidance only and can be modified without prior advice



Because of permanent improvement of our products, drawings, descriptions, features used on these data sheets are for guidance only and can be modified without prior advice

# Electronic room thermostats



Because of permanent improvement of our products, drawings, descriptions, features used on these data sheets are for guidance only and can be modified without prior advice



# Electronic room thermostats for heat tracing, metal box



Because of permanent improvement of our products, drawings, descriptions, features used on these data sheets are for guidance only and can be modified without prior advice

Enclosure	Type	Operation	Contact	Measurement	Ranges °C	Models
IP65, IK10	Control	Electronic	SPNC	Ambient		<b>Y1A2P &amp; Y1B2P</b>
Material <b>Aluminum</b>						

**Y1B2P: External adjustment (With pilot light)**

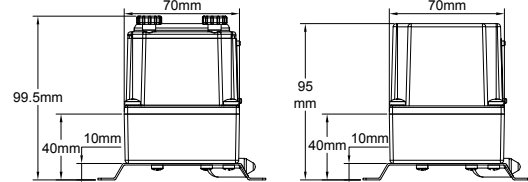
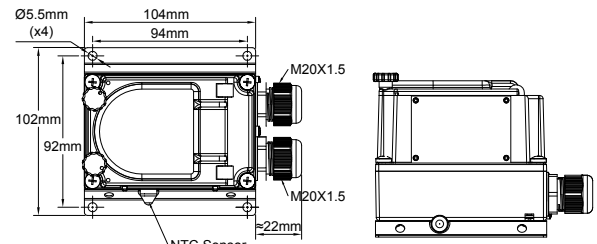

**Y1A2P: Internal adjustment (Without pilot light)**

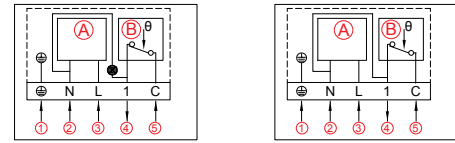
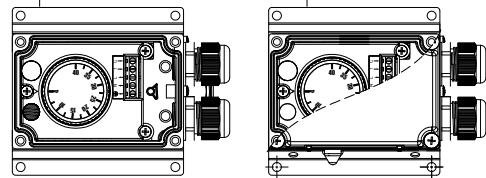
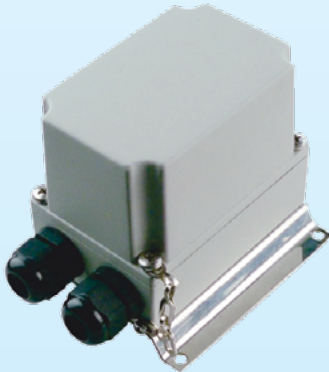

- (A) Electronic circuit      (B) Relay Max 16A 240V res.
- ① Ground      ② Power supply 90-240V Neutral      ③ Power supply 90-240V Line  
④ Relay contact output      ⑤ Relay contact Power supply

Example of assembly on two heat tracing cables of one Y1B2P, in combination with Y29 connection box

Example of assembly on two heat tracing cables, with Y26 connection box with stainless steel elevated bracket, for pipe antifreeze protection.

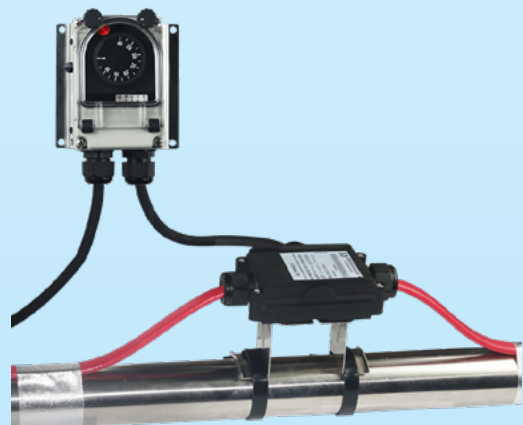



## Applications

- Heavy duty industrial environments
- Outdoor antifreeze temperature control of heaters and heat tracing cables.
- Wall mounting for indoor or outdoor temperature control of cold rooms.
- Temperature control of industrial or commercial premises.
- Green houses and livestock stables temperature control.

## Technical features

**Housing:** Aluminum, IP65, IK10. Mounted on a SUS304 stainless steel wall mounting plate which keeps the temperature sensing element away from the wall. Grey RAL7032 epoxy painting. Stainless steel captive cover screws. Captive aluminum lid.

**Operation:** Microprocessor electronic control thermostat.

Adjustment ranges -35-35°C (-30+95°F), 0-10°C (32-50°F), 4-40°C (40-105°F).

**Set point adjustment:** By °C printed knob. All types have an adjustable rotation limit system located inside the knob that allows reducing the set point adjustment span. Types with external adjustment have a transparent window. This device allows seeing the pilot light and the knob position. °F values are available as an option.

**Sensing element:** NTC probe, mounted on the side of plastic housing.

**Cable input and output:** Two M20 cable glands, Black PA66. Internal electrical connection on screw terminals. 2 phases power supply (Line+ Neutral, 220~250V, 50Hz~60Hz) are mandatory.

**Earthing:** Internal and external screw terminal.

**Pilot light:** Allow to visualize thermostat contact output position. Standard for all models with transparent window. Non-standard and on special request only for models with plain aluminum cover.

**Mounting:** Wall mounting, by 4 holes for screws dia. 4 to 5mm, 94 × 92mm distance.

**Identification:** Metallic identification label, riveted.

**Contact:** SPST. 16A (2.6), 250VAC. Open on temperature rise.

**Electrical life:** >100,000 cycles.

**Minimum storage temperature:** -35°C (-30°F)

**Maximum ambient temperature:** 60°C (140°F)

**Options:** Models with remote temperature sensor

For more technical information on the electronic part, see 2PE2N6 thermostat technical data sheet in catalog N°1

## Main references used in heat tracing



Temperature adjustment ranges °C (°F)	Differential °C (°F)	References with external adjustment	References with internal adjustment
-35-35°C (-30+95°F)	0.5~0.8°C (0.9~1.4°F)	Y1B2PN6F235035AJ	Y1A2PN6F235035AJ
4-40°C (40-105°F)	0.5~0.8°C (0.9~1.4°F)	Y1B2PN6F204040AJ	Y1A2PN6F204040AJ

°F printing: replace last character (J) by K

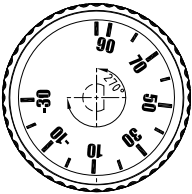
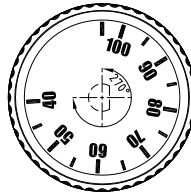
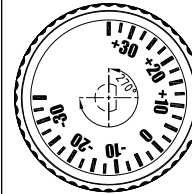
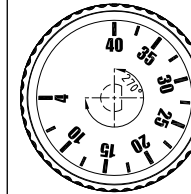
## Knob printings

°F Printing		°C Printing	
-30+95°F	40+105°F	-35+35°C	4-40°C
			

## Similar products

Y1G2P	Y1I2P
Electronic temperature control with distant sensor and internal adjustment	Electronic temperature control with distant sensor and adjustment under window
	

# Electronic room thermostats for heat tracing



Because of permanent improvement of our products, drawings, descriptions, features used on these data sheets are for guidance only and can be modified without prior advice

Enclosure	Type	Operation	Contact	Measurement	Ranges °C	Model
IP66, IK10	Control	Electronic	SPNC	Ambient		YF62NC
Material						
PA66 & PC						

- (A) Electronic circuit
- (B) Relay Max 16A 240V res.
- ① Ground
- ② Power supply 90-240V Neutral
- ③ Power supply 90-240V Line
- ④ Relay contact output
- ⑤ Relay contact Power supply

Example of assembly on two heat tracing cables, in combination with Y29 connection box

Example of assembly on one heat tracing cable, with Y24 connection box, for PVC pipe antifreeze protection

## Applications:

- **Equipment requesting a very strong resistance to water ingress. The transparent cover allows to visualize the set point and the 2 pilot lights.**
- **Outdoor antifreeze temperature control of heaters and heat tracing cables.**
- Wall mounting for indoor or outdoor temperature control of cold rooms.
- Temperature control of industrial or commercial premises.
- Green houses and livestock stables temperature control.

### - Very small differential

**Housing:** Protection class IP 66 upon EN 60529 (waterproof spray water under high pressure and sea splashes, totally dust tight). Body in black PA66, fiber glass reinforced. The transparent polycarbonate cover can be unscrewed by hand, but it is also possible to use a hook spanner. Mechanical impact resistance: IK10. High UV resistance.

**Set point adjustment:** By °C printed knob. All types have an adjustable rotation limit system located inside the knob that allows reducing the set point adjustment span. °F printed knobs available as an option.

# Electronic room thermostats for heat tracing



**Operation:** Microprocessor electronic thermostat,

**Sensing element:** NTC probe, mounted on the top of the plastic housing.

**Pilot lights:** One pilot light visualizes the thermostat contact output position. The other visualizes the power supply input. Phase and line 230V power supply is mandatory for these pilot lights.

**Set point adjustment ranges:** -35-35°C (-30+95°F), 0-10°C (32-50°F), 4-40°C (40-105°F).

**Differential:** Differential is preset at the minimum value, but can be increased with a potentiometer located under the set point adjustment knob.

**Cable input and output:** Two M20 cable glands, built-in, black PA66.

**Electrical connections:** Inside, on screw terminal connection block. It is possible to connect 2 wires 1.5mm<sup>2</sup> on each terminal.

**Earthing:** Internal screw terminal.

**Mounting:** Wall mounting, by 2 legs with holes for screws dia. 4 to 5mm, 114mm distance.

**Identification:** Identification label on backside.

**Contact:** SPST. 16A (2.6), 250VAC. Open on temperature rise.

**Electrical life:** >100.000 cycles.

**Minimum storage temperature:** -35°C (-30°F)

**Maximum ambient temperature:** 60°C (140°F)

**Options:** Models with remote temperature sensor

For more technical information see 2PE2N6 thermostat technical data sheet in catalog N°1

## Main references used in heat tracing

References with open on temperature rise contact	Temperature adjustment ranges °C (°F)*	Minimum differential °C (°F)
YF62NC350350000J	-35+35°C (-30+95°F)	0.5~0.8°C (0.9~1.4°F)
YF62NC000100000J	0+10°C (32-50°F)	0.5~0.8°C (0.9~1.4°F)
YF62NC040400000J	+4+40°C (40-105°F)	0.5~0.8°C (0.9~1.4°F)

\* °F printing: replace last character (J) by K.

## Knob printings

°C Printing			°F Printing		
-35+35°C	0-10°C	4-40°C	-30+95°F	32-50°F	40+105°F

## Model with remote sensor



Because of permanent improvement of our products, drawings, descriptions, features used on these data sheets are for guidance only and can be modified without prior advice



Because of permanent improvement of our products, drawings, descriptions, features used on these data sheets are for guidance only and can be modified without prior advice

# Remote sensor electronic thermostats



Because of permanent improvement of our products, drawings, descriptions, features used on these data sheets are for guidance only and can be modified without prior advice



# Electronic temperature control, remote sensor



Because of permanent improvement of our products, drawings, descriptions, features used on these data sheets are for guidance only and can be modified without prior advice

Enclosure	Type	Operation	Contact	Measurement	Ranges °C	Models
IP65, IK10	Control	Electronic	SPNO or SPNC	Remote		<b>Y112P</b> <b>Y1G2P</b>
Material						
Aluminum						

<p><b>Y112P: External adjustment (With pilot light)</b></p>		<p><b>Y1G2P: Internal adjustment (Without pilot light)</b></p>	
---	--	--	--

## Applications:

Temperature control with reduced differential, on-off action, in usual industrial applications and environments, not hazardous areas.

Internal adjustment is convenient for products that must not be frequently adjusted.

Use of electronic sensor allows **measurement at a long distance**, which is not possible with bulb and capillary types.

**Housing:** Aluminum, IP65, IK10. Mounted on a SUS304 stainless steel wall mounting plate which keeps temperature sensing element away from the wall. Grey RAL7032 epoxy painting. Stainless steel captive cover screws. Captive aluminum lid.

**Operation:** Microprocessor electronic control thermostat.

**Adjustment ranges:** -35-35°C (-30+95°F); 0-10°C (32-50°F); 4-40°C (40-105°F); 30-90°C (85-195°F); 30-110°C (85-230°F); 50-200°C (120-390°F); 50-300°C (120-570°F); 100-400°C (210-750°F); 100-500°C (210-930°F).

**Differential:** Differential is preset at the minimum value, but can be increased with a potentiometer located under the set point adjustment knob.

**Set point adjustment:** By °C printed knob. All types have an adjustable rotation limit system located inside the knob that allows reducing the set point adjustment span. Types with external adjustment have a transparent window. This device allows seeing the pilot light and the knob position. °F values are available as an option.

**Sensing element:** NTC or Pt100 probe, mounted on the side of plastic housing. The sensor cable is protected by a stainless steel corrugated pipe terminated by a silicone tip. A plastic cap plug provided as standard accessory allows locking the flexible metal conduit inside a pocket (See pockets in the accessories section). Standard cable length 2m. Other lengths on request.

**Cable input and output:** Two M20 cable glands, Black PA66. Internal electrical connection on screw terminals. 2 phases power supply (Line+ Neutral, 220~250V, 50Hz~60Hz) are mandatory.

**Earthing:** Internal and external screw terminal.

**Pilot light:** Allow to visualize thermostat contact output position. Standard for all models with transparent window. Non Standard and on special request only for models with plain aluminum cover.

**Mounting:** Wall mounting, by 4 holes for screws dia. 4 to 5mm, 94 × 92mm distance.

**Identification:** Metallic identification label, riveted.

**Contact:** SPST. 16A (2.6), 250VAC. Open or close on temperature rise. (Contact action can be set on the circuit board.) Products are shipped in standard with contact open on temperature rise action, for use in heating applications.

**Electrical life:** >100,000 cycles.

**Minimum storage temperature:** -35°C (-30°F)

**Maximum ambient temperature:** 60°C (140°F)

For more technical information ask 2PE2N6 thermostat technical data sheet.



## Main references

Temperature adjustment ranges °C (°F)	Temperature sensor	References with external adjustment	References with internal adjustment	Differential °C (°F)
-35+35°C (-30+95°F)	NTC (10KOhms @25°C)	Y1I2PN6F2350352J	Y1G2PN6F2350352J	0.5~0.8°C (0.9~1.4°F)
0-10°C (32-50°F)	NTC (10KOhms @25°C)	Y1I2PN6F2000102J	Y1G2PN6F2000102J	0.5~0.8°C (0.9~1.4°F)
4-40°C (40-105°F)	NTC (10KOhms @25°C)	Y1I2PN6F2040402J	Y1G2PN6F2040402J	0.5~0.8°C (0.9~1.4°F)
30-90°C (85-195°F)	NTC (10KOhms @25°C)	Y1I2PN6F2300902J	Y1G2PN6F2300902J	0.5~0.8°C (0.9~1.4°F)
30-110°C (85-230°F)	NTC (10KOhms @25°C)	Y1I2PN6F2301102J	Y1G2PN6F2301102J	0.5~0.8°C (0.9~1.4°F)
50-200°C (120-390°F)	Pt100	Y1I2PP6F2502002J	Y1G2PP6F2502002J	0.5~0.8°C (0.9~1.4°F)
50-300°C (120-570°F)	Pt100	Y1I2PP6F2503002J	Y1G2PP6F2503002J	0.5~0.8°C (0.9~1.4°F)
100-400°C (210-750°F)	Pt100	Y1I2PP6F2A04002J	Y1G2PP6F2A04002J	0.5~0.8°C (0.9~1.4°F)
100-500°C (210-930°F)	Pt100	Y1I2PP6F2A05002J	Y1G2PP6F2A05002J	0.5~0.8°C (0.9~1.4°F)

°F printing: replace last character (J) by K.  
Character 15 gives the sensor cable length (2m).

## Knob printings

°C Printing				
-35+35°C	0-10°C	4-40°C	30-90°C	30-110°C
50-200°C	50-300°C	100-400°C	100-500°C	
°F Printing				
-30+95°F	32-50°F	40-105°F	85-195°F	85-230°F
120-390°F	120-570°F	210-750°F	210-930°F	

Because of permanent improvement of our products, drawings, descriptions, features used on these data sheets are for guidance only and can be modified without prior advice

# Electronic thermostats, remote sensor, IP66 enclosure in PA66 and PC



Because of permanent improvement of our products, drawings, descriptions, features used on these data sheets are for guidance only and can be modified without prior advice

Enclosure	Type	Operation	Contact	Measurement	Ranges °C	Models
IP66, IK10	Control	Electronic	SPNO or SPNC	Remote		<b>YF92NC</b> <b>YF94NC</b>
Material PA66 +PC						

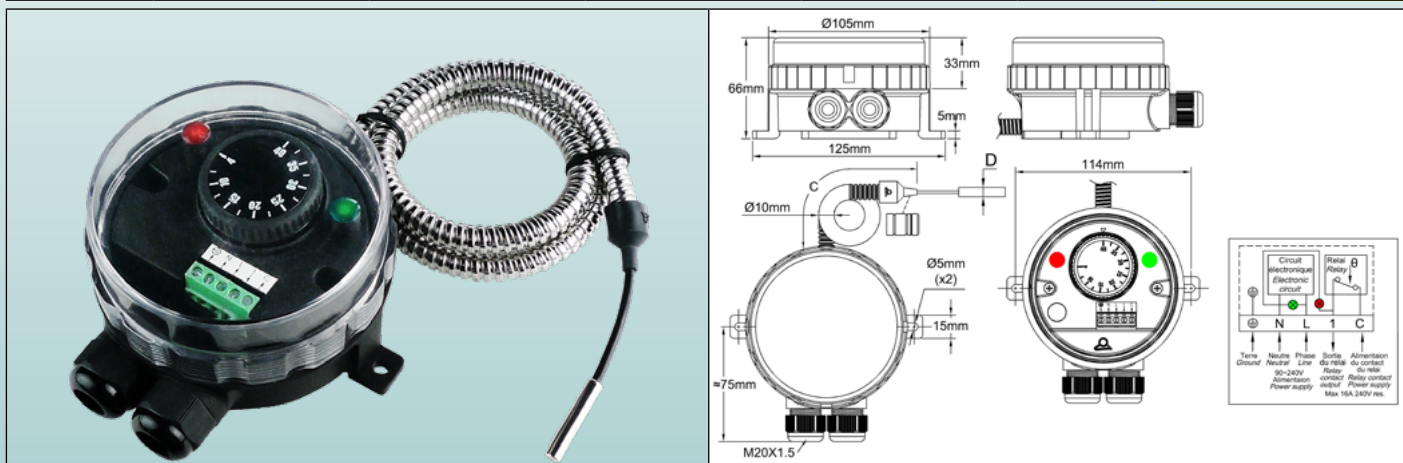

## Applications:

- **Equipment requesting a very strong resistance to water ingress. The transparent cover allows to visualize the set point and the 2 pilot lights.**

Temperature control with reduced differential, on-off action, in usual industrial applications and environments, not hazardous areas.

Use of electronic sensor allows **measurement at long distances**, which is not possible with bulb and capillary types.

- **Very small differential**

**Housing:** Protection class IP 66 upon EN 60529 (waterproof spray water under high pressure and sea splashes, totally dust tight). Body in black PA66, fiber glass reinforced. The transparent polycarbonate cover can be unscrewed by hand, but it is also possible to use a hook spanner. Mechanical impact resistance: IK10. High UV resistance.

**Set point adjustment:** By °C printed knob. All types have an adjustable rotation limit system located inside the knob that allows reducing the set point adjustment span. °F printed knobs available as an option.

**Operation:** Microprocessor electronic thermostat.

**Sensing element:** NTC or Pt100 sensor, diameter D= 5mm. The sensor cable is protected by a stainless steel corrugated pipe terminated by a silicone tip. A plastic cap plug provided as standard accessory allows locking the flexible metal conduit inside a pocket (See pockets in the accessories section). Standard cable length 2m. Other lengths on request.

**Pilot lights:** One pilot light visualizes the thermostat contact output position. The other visualizes the power supply input. Phase and line 230V power supply is mandatory for these pilot lights.

**Set point adjustment ranges:** -35-35°C (-30+95°F); 0-10°C (32-50°F); 4-40°C (40-105°F); 30-90°C (85-195°F); 30-110°C (85-230°F); 50-200°C (120-390°F); 50-300°C (120-570°F); 100-400°C (210-750°F); 100-500°C (210-930°F).

**Differential:** Differential is preset at the minimum value, but can be increased with a potentiometer located under the set point adjustment knob.

**Cable input and output:** Two M20 cable glands, built-in black PA66.

**Electrical connections:** Inside, on screw terminal connection block. It is possible to connect 2 wires 1.5mm<sup>2</sup> on each terminal.

**Earthing:** Internal screw terminal.

**Mounting:** Wall mounting, by 2 legs with holes for screws dia. 4 to 5mm, 114mm distance

**Identification:** Identification label on backside

**Contact:** SPST. 16A (2.6), 250VAC. Open or close on temperature rise. Model with contact closing on temperature rise is used for refrigeration. Version with contact opening on temperature rise is used for heating.

**Electrical life:** >100,000 cycles.

**Minimum storage temperature:** -35°C (-30°F)

**Maximum ambient temperature:** 60°C (140°F)

For more technical information see 2PE2N6 thermostat technical data sheet



## Main references

Temperature adjustment ranges °C (°F)	Temperature sensor	References with SPNC, open on temperature rise contact	References with SPNO, close on temperature rise contact	Differential °C (°F)
-35+35°C (-30+95°F)	NTC (10KOhms @25°C)	YF92NC350352051J	YF94NC350352051J	0.5~0.8°C (0.9~1.4°F)
0-10°C (32-50°F)	NTC (10KOhms @25°C)	YF92NC000102051J	YF94NC000102051J	0.5~0.8°C (0.9~1.4°F)
4-40°C (40-105°F)	NTC (10KOhms @25°C)	YF92NC040402051J	YF94NC040402051J	0.5~0.8°C (0.9~1.4°F)
30-90°C (85-195°F)	NTC (10KOhms @25°C)	YF92NC000902051J	YF94NC000902051J	0.5~0.8°C (0.9~1.4°F)
30-110°C (85-230°F)	NTC (10KOhms @25°C)	YF92NC301102051J	YF94NC301102051J	0.5~0.8°C (0.9~1.4°F)
50-200°C (120-390°F)	Pt100	YF92NC502002051J	YF94NC502002051J	0.5~0.8°C (0.9~1.4°F)
50-300°C (120-570°F)	Pt100	YF92NC503002051J	YF94NC503002051J	0.5~0.8°C (0.9~1.4°F)
100-400°C (210-750°F)	Pt100	YF92NCA04002051J	YF94NCA04002051J	0.5~0.8°C (0.9~1.4°F)
100-500°C (210-930°F)	Pt100	YF92NCA05002051J	YF94NCA05002051J	0.5~0.8°C (0.9~1.4°F)

\*F printing: replace last character (J) by K  
Character 12 gives the sensor cable length (2m)

## Knob printings

°C Printing				
-35+35°C	0-10°C	4-40°C	30-90°C	30-110°C
50-200°C	50-300°C	100-400°C	100-500°C	

°F Printing				
-30+95°F	32-50°F	40-105°F	85-195°F	85-230°F
120-390°F	120-570°F	210-750°F	210-930°F	

Because of permanent improvement of our products, drawings, descriptions, features used on these data sheets are for guidance only and can be modified without prior advice



# Electronic thermostats for immersion heaters



Because of permanent improvement of our products, drawings, descriptions, features used on these data sheets are for guidance only and can be modified without prior advice

Enclosure	Type	Operation	Contact	Measurement	Ranges °C	Model
IP66, IK10	Control	Electronic	SPNC	Immersion heater		<b>YF82NC</b>
Material						
PA66 +PC						

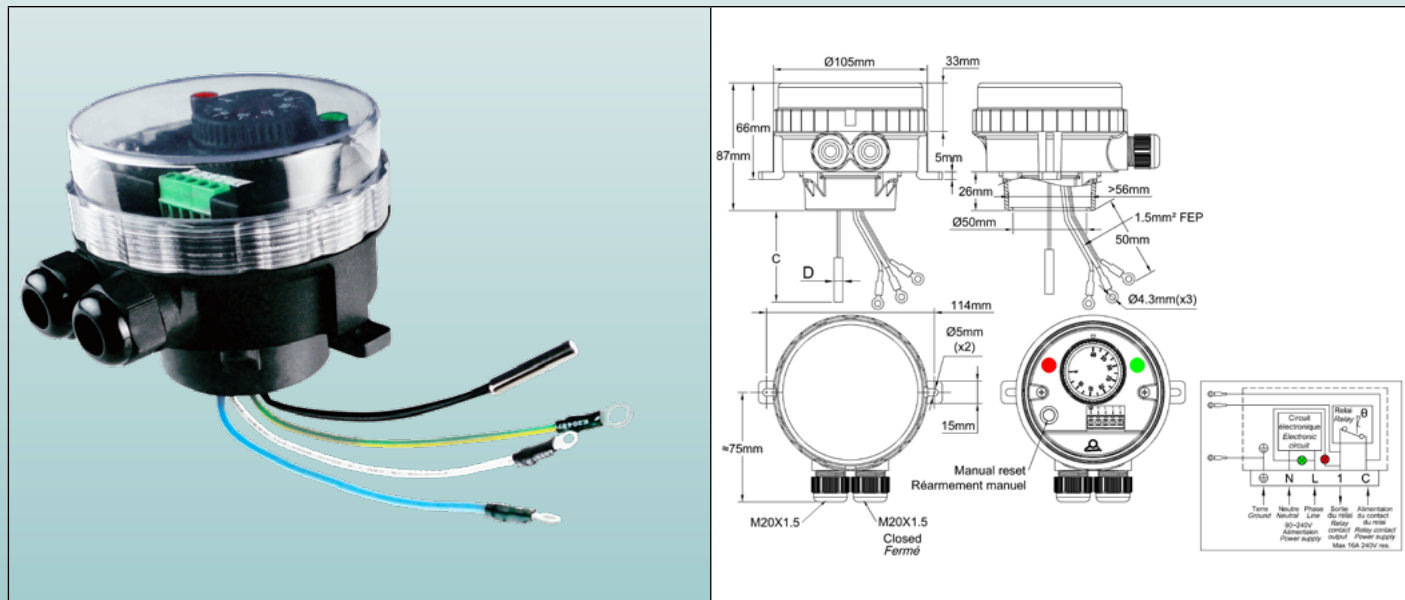

## Applications:

**- Equipment requesting a very strong resistance to water ingress. The transparent cover allows to visualize the set point and the 2 pilot lights**

Fully wired sub assembly for direct mounting on immersion heater elements, 1"1/2 or M45x2 with double thread or rotation ring.

Applications in usual industrial applications and environments, non-hazardous areas.

**- Very small differential**

**Housing:** Protection class IP 66 upon EN 60529 (waterproof spray water under high pressure and sea splashes, totally dust tight). Body in black PA66, fiber glass reinforced. The transparent polycarbonate cover can be unscrewed by hand, but it is also possible to use a hook spanner. A removable adapter is screwed at the bottom of the enclosure. It fits the usual immersion heater fittings. Mechanical impact resistance: IK10. High UV resistance.

**Set point adjustment:** By °C printed knob. All types have an adjustable rotation limit system located inside the knob that allows reducing the set point adjustment span. °F printed knobs available in option

**Operation:** Microprocessor electronic thermostat, on-off action.

**Set point adjustment ranges:** 4-40°C (40-105°F); 30-90°C (85-195°F); 30-110°C (85-230°F).

**Differential:** Differential is preset at the minimum value, but can be increased with a potentiometer located under the set point adjustment knob.

**Sensing element:** The 5 × 30mm NTC sensor (10KOhms @25°C) goes out by the bottom of the enclosure to fit in the immersion heater pocket.

**Pilot lights:** One pilot light visualizes the thermostat contact output position. The other visualizes the power supply input. Phase and line 230V power supply is mandatory for these pilot lights.

**Cable input and output:** Two M20 cable glands, built-in black PA66. One of them is closed.

**Electrical connections:** Inside, on screw terminal connection block.

**Earthing:** Internal screw terminal and 1.5mm² FEP insulated wire with round hole terminals for the immersion heater.

**Mounting:** By the immersion heater thread or by 2 legs with holes for screws dia. 4 to 5mm, 114mm distance

**Identification:** Identification label on backside.

**Contact:** SPNC. 16A (2.6), 250VAC. Contact open on temperature rise

**Electrical life:** >100,000 cycles.

**Minimum storage temperature:** -35°C (-30°F)

**Maximum ambient temperature:** 60°C (140°F)

For more technical information ask 2PE2N6 thermostat technical data sheet.



## Main references

Temperature adjustment ranges °C (°F)	References with SPNC contact, open on temperature rise	NTC sensor cable length (C, mm)	Minimum differential °C (°F)
4-40°C (40-105°F)	YF82NC04040118UJ	110	0.5~0.8°C (0.9~1.4°F)
4-40°C (40-105°F)	YF82NC04040178UJ	170	0.5~0.8°C (0.9~1.4°F)
4-40°C (40-105°F)	YF82NC04040238UJ	230	0.5~0.8°C (0.9~1.4°F)
4-40°C (40-105°F)	YF82NC04040308UJ	300	0.5~0.8°C (0.9~1.4°F)
4-40°C (40-105°F)	YF82NC04040458UJ	450	0.5~0.8°C (0.9~1.4°F)
4-40°C (40-105°F)	YF82NC04040608UJ	600	0.5~0.8°C (0.9~1.4°F)
30-90°C (85-195°F)	YF82NC30090118UJ	110	0.5~0.8°C (0.9~1.4°F)
30-90°C (85-195°F)	YF82NC30090178UJ	170	0.5~0.8°C (0.9~1.4°F)
30-90°C (85-195°F)	YF82NC30090238UJ	230	0.5~0.8°C (0.9~1.4°F)
30-90°C (85-195°F)	YF82NC30090308UJ	300	0.5~0.8°C (0.9~1.4°F)
30-90°C (85-195°F)	YF82NC30090458UJ	450	0.5~0.8°C (0.9~1.4°F)
30-90°C (85-195°F)	YF82NC30090608UJ	600	0.5~0.8°C (0.9~1.4°F)
30-110°C (85-230°F)	YF82NC30110118UJ	110	0.5~0.8°C (0.9~1.4°F)
30-110°C (85-230°F)	YF82NC30110178UJ	170	0.5~0.8°C (0.9~1.4°F)
30-110°C (85-230°F)	YF82NC30110238UJ	230	0.5~0.8°C (0.9~1.4°F)
30-110°C (85-230°F)	YF82NC30110308UJ	300	0.5~0.8°C (0.9~1.4°F)
30-110°C (85-230°F)	YF82NC30110458UJ	450	0.5~0.8°C (0.9~1.4°F)
30-110°C (85-230°F)	YF82NC30110608UJ	600	0.5~0.8°C (0.9~1.4°F)

°F printing: replace last character (J) by K

## Knob printings

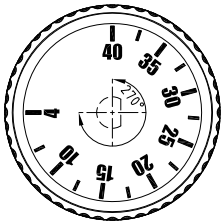
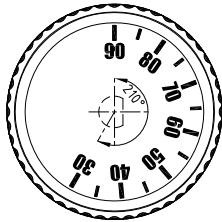
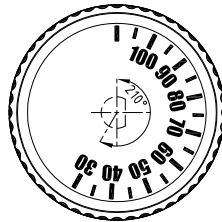
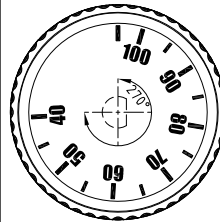
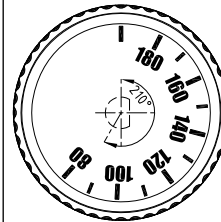
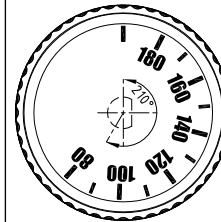
°C Printing			°F Printing		
4-40°C	30-90°C	30-110°C	40-105°F	85-195°F	85-230°F
					

Because of permanent improvement of our products, drawings, descriptions, features used on these data sheets are for guidance only and can be modified without prior advice





## Type: 2DPAP6F

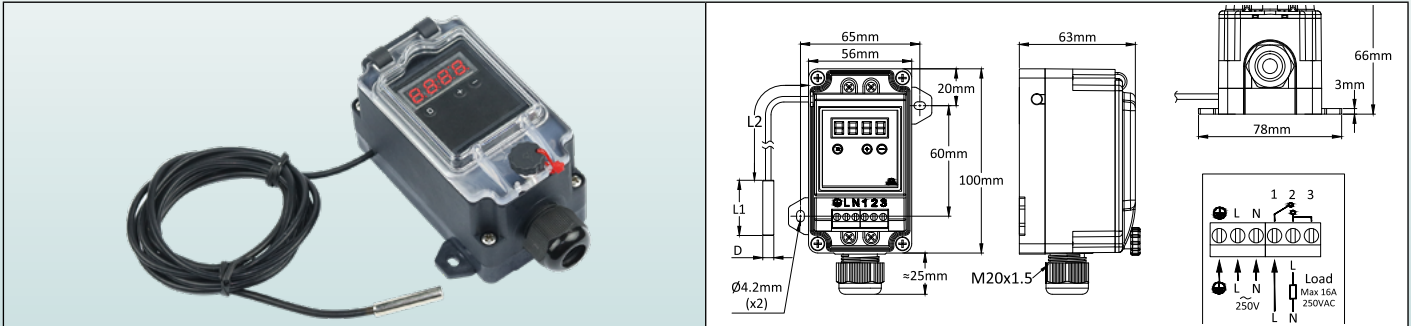

This **ultra-compact** electronic temperature controller was designed to provide the simplest and instinctive end user setting. It can be used by un-trained operators. It provides simple On Off action temperature control.

It is possible to set °C or °F display, heating or cooling relay output, decimal display, sensor type and temperature range by internal Dip switches (Without access by end user).

**End user has only access to set point and differential setting.**

Adjustment of maximum temperature setting allowed to the operator can be set without the need to open the control.

This control is designed to be wall mounted, in industrial or commercial buildings, or in livestock premises in indoor or outdoor applications.

### Main features

**Enclosure:** 100 × 56 × 66mm. In black PA66, impact resistant (IK10), UV resistant, and has the highest ingress protection level: IP69K (resistant to high pressure hot water washing). Transparent polycarbonate window, with gasket and knurled opening screw with possibility of sealing (5 seals supplied as standard).

Wall mounting by two removable legs, 60 × 65mm between axis.

**Display:** 3+1 digit LED. The fourth digit is used to display °C or °F, upon setting made.

**Set point setting:** In normal use, the display shows measured temperature. Push “+” or “-” keys will display the set point value, and at that time it can be adjusted with “+” and “-” keys. No action during 5 seconds will register the new set point value and bring back display to measured value.

**Temperature differential setting:** In normal use, when the display shows measured temperature, push “D” key will display the differential value, at that time it can be adjusted with “+” and “-” keys. Push “D” again or no action during 5 seconds will register the new differential value and bring back display to measured value.

**Action:** On-OFF.

**Temperature sensor:** Pt100 (3 wires) or NTC 10 kilo-ohms @25°C, B= 3380 (2 wires) Temperature sensor can be selected by a dip switch on circuit (No access to final user).

**Accuracy:** +/-1% of scale.

**Temperature adjustment ranges:**

- 30+120°C (-20+250°F), with 1° display
- 30.0 to +40.0°C (-20.0 + 99.9°F), with 1/10° display
- 30+400°C (-20+750°F), with 1° display

Temperature range and decimal digit can be selected by dip switches on circuit (No access to final user).

**Power supply:** 220 to 250V, 50Hz or 60Hz.

**Relay output:** Single pole, 16A250V res., 100.000 cycles. The digital display provides relay position.

**Relay action:** Heating or cooling, (relay contact open or close on temperature rise action) can be selected by a dip switch on circuit (No access to final user).

**°C or °F display:** Can be selected by a dip switch on circuit (No access to final user).

**Maximum possible set point adjustment by user:** Push “D” button more than 10 seconds, display shows the maximum temperature that can be set by user. Then it is possible to adjust this value with “+” and “-”, push again on “D” or do nothing during 5 seconds will register the maximum possible setting value and control will come back to measured valued.

**Ambiant:** -20+60°C, 10-90% RH.

**Power:** <4W.

**Safety:**

- If there is no power supply to the electronic board, relay output contact will open
- If Pt100 sensor or NTC is broken or not connected properly, relay output contact will open and display will show “EEE”
- If measured temperature is higher than allowed by the set range, display will show HHH
- If measured temperature is lower than -30.0°C or -20.0°F, display will show LLL

**Electrical connections:**

- Power input for electronic board: Neutral, phase, ground, with 2.5mm<sup>2</sup> terminals
- Relay input and output: 2.5mm<sup>2</sup> terminals.
- Temperature sensor: three 2.5mm<sup>2</sup> screw terminal. Access to these terminals is possible only after removing the internal cover.



**Internal parameters setting:** Process is given on request to approved distributors. This allows to store only one product and set parameters upon end user request.

**Connected temperature sensors:** These devices are usually supplied with a connected temperature sensor. If the standard sensor model does not suit you, there are many other models in our range. Consult our sales department. On request these boxes can also be delivered without sensor, for use of customer sensors. (Subject to compatibility of the connecting cable diameter).

**Compliance with Standards:** Comply with LVD, EMC (CE certificate by TÜV) and ROHS

## Main references

Heating control						
References	Temperature range	Sensor	Display digit point	Display Unit	Relay Output	Sensor connected
2DPAP6FEB2503F20	-30.0 to +40.0°C	Pt100	88.8	°C	Heating	TSR50030I2000BK6
2DPAP6FAN1503P20	-30+120°C	NTC	888	°C	Heating	TNR60030C20001F
2DPAP6FIB2503F20	-30+400°C	Pt100	888	°C	Heating	TSR50030I2000BK6*
2DPAP6FIB2610G20	-30+400°C	Pt100	888	°C	Heating	TSS40050I2000BK6**
2DPAP6FBN1503P20	-20+250°F	NTC	888	°F	Heating	TNR60030C20001F
2DPAP6FFB2503F20	-20.0 + 99.9°F	Pt100	88.8	°F	Heating	TSR50030I2000BK6
2DPAP6FJB2503F20	-20+750°F	Pt100	888	°F	Heating	TSR50030I2000BK6*
2DPAP6FJB2610G20	-20+750°F	Pt100	888	°F	Heating	TSS40050I2000BK6**
Cooling or fan control						
References	Temperature range	Sensor	Display digit point	Display Unit	Relay Output	Sensor connected
2DPAP6FGB2503F20	-30.0 to +40.0°C	Pt100	88.8	°C	Cooling	TSR50030I2000BK6
2DPAP6FCN1503P20	-30+120°C	NTC	888	°C	Cooling	TNR60030C20001F
2DPAP6FKB2503F20	-30+400°C	Pt100	888	°C	Cooling	TSR50030I2000BK6*
2DPAP6FHB2503F20	-20.0 + 99.9°F	Pt100	88.8	°F	Cooling	TSR50030I2000BK6
2DPAP6FDN1503P20	-20+250°F	NTC	888	°F	Cooling	TNR60030C20001F
2DPAP6FLB2503F20	-20+750°F	Pt100	888	°F	Cooling	TSR50030I2000BK6*
<b>No internal setting made, sold only to approved distributors.</b>						
2DPAP6FO						Without

\*: This sensor can be used only up to 200°C (390°F)

\*\* : This sensor can be used up to 400°C (750°F).

## Standard temperature sensors

NTC Thermistor	Pt100, 3 wires, 200°C	Pt100, 3 wires, 400°C
<p><b>Value:</b> 10Kohms @25°C, B= 3380  <b>Accuracy:</b> +/-1% on R25 e+/-1% on B  <b>Temperature range:</b> -20°C+120°C  <b>Probe:</b> Nickel plated copper, 6 x 30mm  <b>Cable:</b> AWG24, FEP + silicone insulation, dia 3.3mm, length 2m</p>	<p><b>Accuracy and tolerances:</b>                      Class B, ±0.3°C @ 0°C. (±0.12 Ω @ 0°C).  <b>Temperature range:</b> -50°C, +200°C  <b>Probe:</b> Stainless Steel 304, dia. 5mm x 30mm  <b>Cable:</b> 3 x AWG24, FEP insulation, + metal braid + FEP, T 200°C, dia. 3mm, length 2m</p>	<p><b>Accuracy and tolerances:</b>                      Class B, ±0.3°C @ 0°C. (±0.12 Ω @ 0°C).  <b>Probe temperature range:</b> -50°C, +400°C  <b>Probe:</b> Stainless Steel 304, dia. 4mm x 500mm  <b>Cable:</b> 3 x AWG24, FEP insulation, + metal braid + FEP, T 200°C, dia. 2.7mm, length 2m</p>
Reference: TNR60030C20001F6	Reference: TSR50030I2000BK6	Reference: TSS40050I2000BK6

Because of permanent improvement of our products, drawings, descriptions, features used on these data sheets are for guidance only and can be modified without prior advice



Because of permanent improvement of our products, drawings, descriptions, features used on these data sheets are for guidance only and can be modified without prior advice

# Electronic thermostats, with rod sensor or pipe mounting



Because of permanent improvement of our products, drawings, descriptions, features used on these data sheets are for guidance only and can be modified without prior advice

# Electronic temperature control, rod



Because of permanent improvement of our products, drawings, descriptions, features used on these data sheets are for guidance only and can be modified without prior advice

Enclosure	Type	Operation	Contact	Measurement	Ranges °C	Models
IP65, IK10	Control	Electronic	SPNO or SPNC	Rod		<b>Y1S2P</b> <b>Y1R2P</b>
Material						
Aluminum						

<p>Y1S2P: External adjustment (With pilot light)</p>		<p>Y1R2P: Internal adjustment (Without pilot light)</p>	
--	--	---	--

## Applications:

These rod thermostats with **electronic sensor** can be installed inside pockets as immersion thermostats in pipelines and containers, and for monitoring temperature in air ducts, in usual industrial applications and environments. (Not suitable for hazardous areas).

**Very low differential. On-Off action**

**Internal adjustment is convenient for products that must not be frequently adjusted.**

**Housing:** Aluminum, IP65, IK10. Grey RAL7032 epoxy painting. Stainless steel captive cover screws. Captive aluminum lid.

**Operation:** Microprocessor electronic control thermostat.

**Adjustment ranges:** -35-35°C (-30+95°F); 0-10°C (32-50°F); 4-40°C (40-105°F); 30-90°C (85-195°F); 30-110°C (85-230°F); 50-200°C (120-390°F); 50-300°C (120-570°F); 100-400°C (210-750°F); 100-500°C (210-930°F).

**Set point adjustment:** By °C printed knob. All types have an adjustable rotation limit system located inside the knob that allows reducing the set point adjustment span. Types with external adjustment have a transparent window. This device allows seeing the pilot light and the knob position. °F values are available as an option.

**Sensing element:** NTC or Pt100 sensor located at the end of a dia.8mm stainless steel rod. An increased diameter under the thermostat head allows mounting pockets, coolers or brackets (See pockets in the accessories section)

**Cable input and output:** Two M20 cable glands, Black PA66. Internal electrical connection on screw terminals. 2 phases power supply (Line+ Neutral, 220~250V, 50Hz~60Hz) are mandatory.

**Earthing:** Internal and external screw terminal.

**Pilot light:** Allow to visualize thermostat contact output position. Standard for all models with transparent window. Non Standard and on special request only for models with plain aluminum cover.

**Identification:** Metallic identification label, riveted.

**Contact:** SPST. 16A (2.6), 250VAC. Open or close on temperature rise. (Contact action can be set on the circuit board.) Products are shipped in standard with contact open on temperature rise action, for use in heating applications.

**Electrical life:** >100,000 cycles.

**Minimum storage temperature:** -35°C (-30°F)

**Maximum ambient temperature:** 60°C (140°F)

For more technical information see 2PE2N6 thermostat technical data sheet

## Main references (Rod dia. 8mm)

Temperature adjustment ranges °C (°F)	References with external adjustment	References with internal adjustment	Temperature sensor	Rod length* (L, mm)	Differential °C (°F)
-35-35°C (-30+95°F)	Y1S2PN6F235035BJ	Y1R2PN6F235035BJ	NTC (10KOhms @25°C)	90	0.5~0.8°C (0.9~1.4°F)
-35-35°C (-30+95°F)	Y1S2PN6F235035CJ	Y1R2PN6F235035CJ	NTC (10KOhms @25°C)	110	0.5~0.8°C (0.9~1.4°F)
-35-35°C (-30+95°F)	Y1S2PN6F235035DJ	Y1R2PN6F235035DJ	NTC (10KOhms @25°C)	170	0.5~0.8°C (0.9~1.4°F)
-35-35°C (-30+95°F)	Y1S2PN6F235035EJ	Y1R2PN6F235035EJ	NTC (10KOhms @25°C)	230	0.5~0.8°C (0.9~1.4°F)
-35-35°C (-30+95°F)	Y1S2PN6F235035FJ	Y1R2PN6F235035FJ	NTC (10KOhms @25°C)	300	0.5~0.8°C (0.9~1.4°F)

# Electronic temperature control, rod



Temperature adjustment ranges °C (°F)	References with external adjustment	References with internal adjustment	Temperature sensor	Rod length* (L, mm)	Differential °C (°F)
-35-35°C (-30+95°F)	Y1S2PN6F235035GJ	Y1R2PN6F235035GJ	NTC (10KOhms @25°C)	450	0.5~0.8°C (0.9~1.4°F)
0-10°C (32-50°F)	Y1G2PN6F2000102J	Y1R2PN6F200010CJ	NTC (10KOhms @25°C)	110	0.5~0.8°C (0.9~1.4°F)
0-10°C (32-50°F)	Y1S2PN6F200010CJ	Y1R2PN6F200010EJ	NTC (10KOhms @25°C)	230	0.5~0.8°C (0.9~1.4°F)
0-10°C (32-50°F)	Y1S2PN6F200010EJ	Y1R2PN6F200010FJ	NTC (10KOhms @25°C)	300	0.5~0.8°C (0.9~1.4°F)
0-10°C (32-50°F)	Y1S2PN6F200010FJ	Y1R2PN6F200010GJ	NTC (10KOhms @25°C)	450	0.5~0.8°C (0.9~1.4°F)
4-40°C (40-105°F)	Y1S2PN6F204040BJ	Y1R2PN6F204040BJ	NTC (10KOhms @25°C)	90	0.5~0.8°C (0.9~1.4°F)
4-40°C (40-105°F)	Y1S2PN6F204040CJ	Y1R2PN6F204040CJ	NTC (10KOhms @25°C)	110	0.5~0.8°C (0.9~1.4°F)
4-40°C (40-105°F)	Y1S2PN6F204040DJ	Y1R2PN6F204040DJ	NTC (10KOhms @25°C)	170	0.5~0.8°C (0.9~1.4°F)
4-40°C (40-105°F)	Y1S2PN6F204040EJ	Y1R2PN6F204040EJ	NTC (10KOhms @25°C)	230	0.5~0.8°C (0.9~1.4°F)
4-40°C (40-105°F)	Y1S2PN6F204040FJ	Y1R2PN6F204040FJ	NTC (10KOhms @25°C)	300	0.5~0.8°C (0.9~1.4°F)
4-40°C (40-105°F)	Y1S2PN6F204040GJ	Y1R2PN6F204040GJ	NTC (10KOhms @25°C)	450	0.5~0.8°C (0.9~1.4°F)
30-90°C (85-195°F)	Y1S2PN6F230090BJ	Y1R2PN6F230090BJ	NTC (10KOhms @25°C)	90	0.5~0.8°C (0.9~1.4°F)
30-90°C (85-195°F)	Y1S2PN6F230090CJ	Y1R2PN6F230090CJ	NTC (10KOhms @25°C)	110	0.5~0.8°C (0.9~1.4°F)
30-90°C (85-195°F)	Y1S2PN6F230090DJ	Y1R2PN6F230090DJ	NTC (10KOhms @25°C)	170	0.5~0.8°C (0.9~1.4°F)
30-90°C (85-195°F)	Y1S2PN6F230090EJ	Y1R2PN6F230090EJ	NTC (10KOhms @25°C)	230	0.5~0.8°C (0.9~1.4°F)
30-90°C (85-195°F)	Y1S2PN6F230090FJ	Y1R2PN6F230090FJ	NTC (10KOhms @25°C)	300	0.5~0.8°C (0.9~1.4°F)
30-90°C (85-195°F)	Y1S2PN6F230090GJ	Y1R2PN6F230090GJ	NTC (10KOhms @25°C)	450	0.5~0.8°C (0.9~1.4°F)
30-90°C (85-195°F)	Y1S2PN6F230090HJ	Y1R2PN6F230090HJ	NTC (10KOhms @25°C)	600	0.5~0.8°C (0.9~1.4°F)
30-90°C (85-195°F)	Y1S2PN6F230090JJ	Y1R2PN6F230090JJ	NTC (10KOhms @25°C)	800	0.5~0.8°C (0.9~1.4°F)
30-110°C (85-230°F)	Y1S2PN6F230110BJ	Y1R2PN6F230110BJ	NTC (10KOhms @25°C)	90	0.5~0.8°C (0.9~1.4°F)
30-110°C (85-230°F)	Y1S2PN6F230110CJ	Y1R2PN6F230110CJ	NTC (10KOhms @25°C)	110	0.5~0.8°C (0.9~1.4°F)
30-110°C (85-230°F)	Y1S2PN6F230110DJ	Y1R2PN6F230110DJ	NTC (10KOhms @25°C)	170	0.5~0.8°C (0.9~1.4°F)
30-110°C (85-230°F)	Y1S2PN6F230110EJ	Y1R2PN6F230110EJ	NTC (10KOhms @25°C)	230	0.5~0.8°C (0.9~1.4°F)
30-110°C (85-230°F)	Y1S2PN6F230110FJ	Y1R2PN6F230110FJ	NTC (10KOhms @25°C)	300	0.5~0.8°C (0.9~1.4°F)
30-110°C (85-230°F)	Y1S2PN6F230110GJ	Y1R2PN6F230110GJ	NTC (10KOhms @25°C)	450	0.5~0.8°C (0.9~1.4°F)
30-110°C (85-230°F)	Y1S2PN6F230110HJ	Y1R2PN6F230110HJ	NTC (10KOhms @25°C)	600	0.5~0.8°C (0.9~1.4°F)
30-110°C (85-230°F)	Y1S2PN6F230110JJ	Y1R2PN6F230110JJ	NTC (10KOhms @25°C)	800	0.5~0.8°C (0.9~1.4°F)
30-110°C (85-230°F)	Y1S2PN6F230110KJ	Y1R2PN6F230110KJ	NTC (10KOhms @25°C)	1000	0.5~0.8°C (0.9~1.4°F)
50-200°C (120-390°F)	Y1S2PP6F250200EJ	Y1R2PP6F250200EJ	Pt100	230	0.5~0.8°C (0.9~1.4°F)
50-200°C (120-390°F)	Y1S2PP6F250200FJ	Y1R2PP6F250200FJ	Pt100	300	0.5~0.8°C (0.9~1.4°F)
50-200°C (120-390°F)	Y1S2PP6F250200GJ	Y1R2PP6F250200GJ	Pt100	450	0.5~0.8°C (0.9~1.4°F)
50-200°C (120-390°F)	Y1S2PP6F250200HJ	Y1R2PP6F250200HJ	Pt100	600	0.5~0.8°C (0.9~1.4°F)
50-200°C (120-390°F)	Y1S2PP6F250200JJ	Y1R2PP6F250200JJ	Pt100	800	0.5~0.8°C (0.9~1.4°F)
50-300°C (120-570°F)	Y1S2PP6F250300FJ	Y1R2PP6F250300FJ	Pt100	300	0.5~0.8°C (0.9~1.4°F)
50-300°C (120-570°F)	Y1S2PP6F250300GJ	Y1R2PP6F250300GJ	Pt100	450	0.5~0.8°C (0.9~1.4°F)
50-300°C (120-570°F)	Y1S2PP6F250300HJ	Y1R2PP6F250300HJ	Pt100	600	0.5~0.8°C (0.9~1.4°F)
100-400°C (210-750°F)	Y1S2PP6F2A0400FJ	Y1R2PP6F2A0400FJ	Pt100	300	0.5~0.8°C (0.9~1.4°F)
100-400°C (210-750°F)	Y1S2PP6F2A0400GJ	Y1R2PP6F2A0400GJ	Pt100	450	0.5~0.8°C (0.9~1.4°F)
100-400°C (210-750°F)	Y1S2PP6F2A0400HJ	Y1R2PP6F2A0400HJ	Pt100	600	0.5~0.8°C (0.9~1.4°F)
100-500°C (210-930°F)	Y1S2PP6F2A0500FJ	Y1R2PP6F2A0500FJ	Pt100	300	0.5~0.8°C (0.9~1.4°F)
100-500°C (210-930°F)	Y1S2PP6F2A0500GJ	Y1R2PP6F2A0500GJ	Pt100	450	0.5~0.8°C (0.9~1.4°F)
100-500°C (210-930°F)	Y1S2PP6F2A0500HJ	Y1R2PP6F2A0500HJ	Pt100	600	0.5~0.8°C (0.9~1.4°F)

\*F printing: replace last character (J) by K

\* Above 200°C we recommend to use a rod cooler reference 66RF07015 or 66RF0701F12 between the rod and the enclosure (see accessories).  
Caution: This cooler reduces the usable rod length by 70mm.

## Knob printings

°C Printing							
-35+35°C	4-40°C	30-90°C	30-110°C	50-200°C	50-300°C	100-400°C	100-500°C
°F Printing							
-30+95°F	40-105°F	85-195°F	85-230°F	120-390°F	120-570°F	210-750°F	210-930°F



# Pipe mounting electronic temperature control



Because of permanent improvement of our products, drawings, descriptions, features used on these data sheets are for guidance only and can be modified without prior advice

Enclosure	Type	Operation	Contact	Measurement	Ranges °C	Models
IP65, IK10	Control	Electronic	SPNO or SPNC	Pipe		<b>Y112P</b> <b>Y102P</b>
Material						
Aluminum						

<p>Y112P: External adjustment (With pilot light)</p>		<p>Y102P: Internal adjustment (Without pilot light)</p>	
--	--	---	--

## Applications:

Pipes surface temperature control in usual industrial applications and environments, **when a low differential is requested** (No suitable for hazardous areas)

Internal adjustment is convenient for products that must not be frequently adjusted.

**Housing:** Aluminum, IP65, IK10. Mounted on a SUS304 stainless steel wall mounting plate which keeps the temperature sensing element away from the wall. Grey RAL7032 epoxy painting. Stainless steel captive cover screws. Captive aluminum lid.

**Set point adjustment ranges:** 4-40°C (40-105°F); 30-90°C (85-195°F).

**Set point adjustment:** By °C printed knob. All types have an adjustable rotation limit system located inside the knob that allows reducing the set point adjustment span. Types with external adjustment have a transparent window. This device allows seeing the pilot light and the knob position. °F values are available as an option.

**Action:** Temperature control, On-Off action

**Sensing element:** NTC sensor inside aluminum bracket in contact with the pipe surface.

The bracket design provides optimized thermal contact with 34mm (1", DN25), 60mm (2", DN50) and 90mm (3", DN80) outside diameter tubes. For intermediate sizes, we recommend the use of thermal grease.

**Electrical connections:** Inside, on screw terminal connection block

**Earthing:** Internal and external screw terminal.

**Pilot light:** Allows to visualize thermostat contact output position. Standard for all models with transparent window. Non Standard and on special request only for models with plain aluminum cover

**Cable input and output:** Two M20 cable glands, Black PA66.

**Mounting:** The thermostat housing can be fixed on the pipe by worm drive hose clamps (DIN3017), nylon cable ties (Tie wraps upon EN50146, for applications at permanent temperature lower than 85°C), or specific stainless steel punched band (see accessories at the end of this catalog).

**Identification:** Metallic identification labels, riveted.

**Contact:** SPST. 16A (2.6), 250VAC. Open or close on temperature rise. The version with contact closing on temperature rise is used to switch on an alarm or a cooling device. The version with contact opening on temperature rise is used to switch off heating.

**Electrical life:** >100,000 cycles.

**Minimum storage temperature:** -35°C (-30°F)

**Maximum ambient temperature:** 60°C (140°F)

For more technical information ask 2PE2N6 thermostat technical data sheet.



## Main references

Temperature adjustment ranges °C (°F)	Open on temperature rise contact		Close on temperature rise contact		Differential °C (°F)	Max. temperature on tube °C (°F)
	Reference with external adjustment	Reference with internal adjustment	Reference with external adjustment	Reference with internal adjustment		
4-40°C (40-105°F)	Y112PN6F204040AJ	Y102PN6F204040AJ	Y112PN6G204040AJ	Y102PN6G204040AJ	0.5~0.8°C (0.9~1.4°F)	100°C (212°F)
30-90°C (85-195°F)	Y112PN6F230090AJ	Y102PN6F230090AJ	Y112PN6G230090AJ	Y102PN6G230090AJ	0.5~0.8°C (0.9~1.4°F)	100°C (212°F)

°F printing: replace last character (J) by K.

## Knobs printing

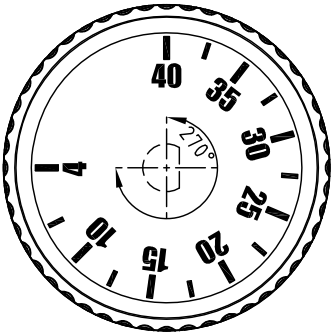
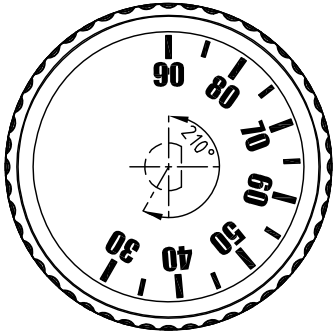
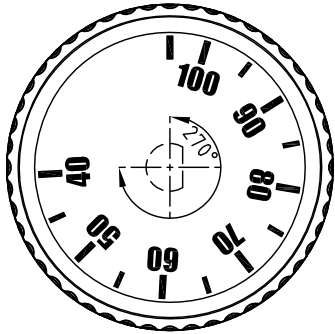
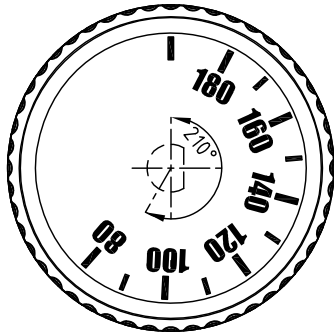
°C Printing		°F Printing	
4-40°C	30-90°C	40-105°F	85-195°F
			

Because of permanent improvement of our products, drawings, descriptions, features used on these data sheets are for guidance only and can be modified without prior advice

# Electronic thermostats, rod sensor



Enclosure	Type	Operation	Contact	Measurement	Ranges °C	Models
IP66, IK10	Control	Electronic	SPNO or SPNC	Probe		<b>YF42NC</b> <b>YF44NC</b>
Material PA66 & PC						

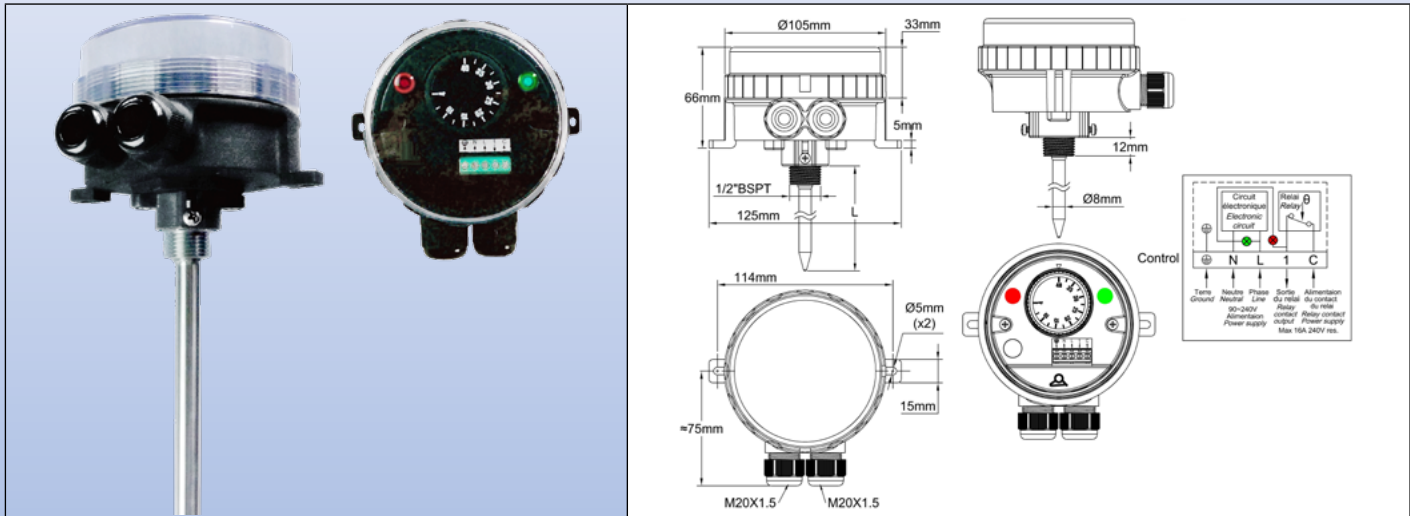

## Applications:

- **Equipment requesting a very strong resistance to water ingress. The transparent cover allows to visualize the set point and the 2 pilot lights**

Temperature control with reduced differential, on-off action, in usual industrial applications and environments, not hazardous areas.

These **electronic** rod thermostats are installed inside pockets as immersion thermostats in pipelines and containers, and for monitoring temperature in air ducts. (Not suitable for hazardous areas).

- **Very small differential**

**Housing:** Protection class IP 66 upon EN 60529 (waterproof spray water under high pressure and sea splashes, totally dust tight). Body in black PA66, fiber glass reinforced. The transparent polycarbonate cover can be unscrewed by hand, but it is also possible to use a hook spanner. Mechanical impact resistance: IK10. High UV resistance.

**Set point adjustment:** By °C printed knob. All types have an adjustable rotation limit system located inside the knob that allows reducing the set point adjustment span. °F printed knobs available as an option

**Operation:** Microprocessor electronic thermostat, on-off action

**Set point adjustment ranges:** -4-40°C (40-105°F); 30-90°C (85-195°F); 30-110°C (85-230°F).

**Differential:** Differential is preset at the minimum value, but can be increased with a potentiometer located under the set point adjustment knob.

**Sensing element:** Dia. 5mm NTC sensor (10KOhms @25°C), inside nickel plated brass pocket. Thread ½" BSPT. Tube outside diameter 8mm. Maximum temperature on the probe: 120°C (250°F). Located at the bottom of the housing, 2 screws are used to secure standard pockets. (See the compatible brass pockets range in the accessories section).

**Pilot lights:** One pilot light visualizes the thermostat contact output position. The other visualizes the power supply input. Phase and line 230V power supply is mandatory for these pilot lights.

**Cable input and output:** Two M20 cable glands, built-in black PA66.

**Electrical connections:** Inside, on screw terminal connection block. It is possible to connect 2 wires 1.5mm<sup>2</sup> on each terminal.

**Earthing:** Internal screw terminal.

**Mounting:** By the pocket thread or by 2 legs with holes for screws dia. 4 to 5mm, 114mm distance.

**Identification:** Identification label on backside.

**Contact:** SPST. 16A (2.6), 250VAC. Open or close on temperature rise. Model with contact closing on temperature rise is used for refrigeration. Version with contact opening on temperature rise is used for heating.

**Electrical life:** >100,000 cycles.

**Minimum storage temperature:** -35°C (-30°F)

**Maximum ambient temperature:** 60°C (140°F)

For more technical information see 2PE2N6 thermostat technical data sheet



## Main references

Temperature adjustment ranges °C (°F)	References with SPNC contact, open on temperature rise	References with SPNO contact, close on temperature rise	Pocket length (L, mm)	Temperature sensing length (mm)	Differential °C (°F)
4-40°C (40-105°F)	YF42NC04040118UJ	YF44NC04040118UJ	110	50	0.5~0.8°C (0.9~1.4°F)
4-40°C (40-105°F)	YF42NC04040178UJ	YF44NC04040178UJ	170	50	0.5~0.8°C (0.9~1.4°F)
4-40°C (40-105°F)	YF42NC04040238UJ	YF44NC04040238UJ	230	50	0.5~0.8°C (0.9~1.4°F)
4-40°C (40-105°F)	YF42NC04040308UJ	YF44NC04040308UJ	300	50	0.5~0.8°C (0.9~1.4°F)
4-40°C (40-105°F)	YF42NC04040458UJ	YF44NC04040458UJ	450	50	0.5~0.8°C (0.9~1.4°F)
4-40°C (40-105°F)	YF42NC04040608UJ	YF44NC04040608UJ	600	50	0.5~0.8°C (0.9~1.4°F)
30-90°C (85-195°F)	YF42NC30090118UJ	YF44NC30090118UJ	110	50	0.5~0.8°C (0.9~1.4°F)
30-90°C (85-195°F)	YF42NC30090178UJ	YF44NC30090178UJ	170	50	0.5~0.8°C (0.9~1.4°F)
30-90°C (85-195°F)	YF42NC30090238UJ	YF44NC30090238UJ	230	50	0.5~0.8°C (0.9~1.4°F)
30-90°C (85-195°F)	YF42NC30090308UJ	YF44NC30090308UJ	300	50	0.5~0.8°C (0.9~1.4°F)
30-90°C (85-195°F)	YF42NC30090458UJ	YF44NC30090458UJ	450	50	0.5~0.8°C (0.9~1.4°F)
30-90°C (85-195°F)	YF42NC30090608UJ	YF44NC30090608UJ	600	50	0.5~0.8°C (0.9~1.4°F)
30-110°C (85-230°F)	YF42NC30110118UJ	YF44NC30110118UJ	110	50	0.5~0.8°C (0.9~1.4°F)
30-110°C (85-230°F)	YF42NC30110178UJ	YF44NC30110178UJ	170	50	0.5~0.8°C (0.9~1.4°F)
30-110°C (85-230°F)	YF42NC30110238UJ	YF44NC30110238UJ	230	50	0.5~0.8°C (0.9~1.4°F)
30-110°C (85-230°F)	YF42NC30110308UJ	YF44NC30110308UJ	300	50	0.5~0.8°C (0.9~1.4°F)
30-110°C (85-230°F)	YF42NC30110458UJ	YF44NC30110458UJ	450	50	0.5~0.8°C (0.9~1.4°F)
30-110°C (85-230°F)	YF42NC30110608UJ	YF44NC30110608UJ	600	50	0.5~0.8°C (0.9~1.4°F)

°F printing: replace last character (J) by K.

## Knobs printing



°C Printing			°F Printing		
4-40°C	30-90°C	30-110°C	40-105°F	85-195°F	85-230°F

Because of permanent improvement of our products, drawings, descriptions, features used on these data sheets are for guidance only and can be modified without prior advice

**Low differential electronic rod thermostat**, with high corrosion resistance housing, specifically designed for surface treatment baths, and highly basic or acid corrosive liquids or environments.

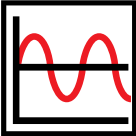
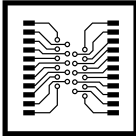
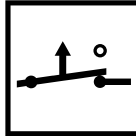

Because of permanent improvement of our products, drawings, descriptions, features used on these data sheets are for guidance only and can be modified without prior advice

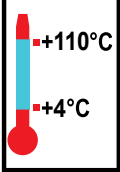
Environnement	Type	Operation	Contact	Measurement	Ranges °C	Model
IP66, IK10	Control	Electronic	SPNC	Rod	+110°C +4°C	<b>YF52</b>
						

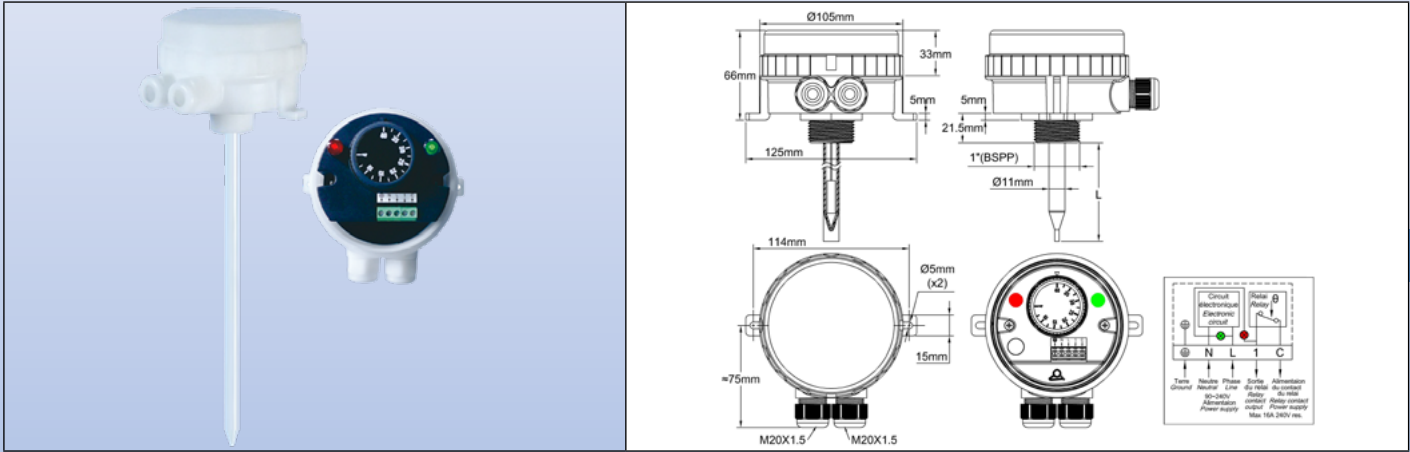

## Main applications

**Precise temperature control** for surface treatment or corrosive liquid baths, sea water environment, livestock premises.

**Housing:** Protection class IP 66 upon EN 60529 (waterproof spray water under high pressure and sea splashes, totally dust tight), dia. 105mm, height 66mm (excluding accessories and cable glands), made of plastic. Includes an adjustable thermostat that can be set after unscrewing the cover. To eliminate the enclosure risk of corrosion, there is no metallic part in contact with the external environment. Cover gasket and cable gland stuffing sets gaskets are made in EPDM. Rod seal is made of fluorocarbon elastomer FKM (Viton). The cover can be unscrewed by hand, but it is also possible to use a hook spanner.

**Electrical connections:** Cable input/output by two M20 cable glands. Electrical connection on screw terminals

**Temperature Adjustment:** Inside, with °C printed knob. (°F printed knobs available in option). Knobs have an invisible device to reduce the temperature range span.

**Sensing element:** NTC thermistor and microprocessor electronic circuit.

**Adjustment ranges:** 4-40°C (32- 104°F); 30-90°C (85-195°F); 30-110°C (90-230°F)

**Rod dimensions:** Outside diameter (D) before optional sleeving is 10mm. Length (L): 450mm, 600mm (300mm, 800mm and 1000mm on request )

**Rod material and sleeving:**

- SUS 316L without sleeving
- Titanium
- SUS 316L with shrunk PTFE sleeve, thickness 0.4 to 0.6mm

**Mounting:**

- By the 1" BSPT thread (Mounting through wall is watertight when used with the 1" nut and seal. See accessories)
- By a rotatable plastic bracket, enabling mounting on tank edge (See accessories)
- By the 2 legs on the side (2 holes dia 5mm center distance 113mm)

**Electrical contact:**

- SPNC, Open on temperature rise contact (C-1) 16A (2.6) 250VAC
- Electrical life >100,000 cycles.

Power supply and power output pilot lights (Neutral is mandatory).

**Cover and housing material options:**

- Black PA66, glass filled body, and polycarbonate (PC) transparent, suitable for most applications in low to medium corrosive liquids, up to 90 °C. Allows to view constantly input and output power supply and thermostat set point. Excellent mechanical strength of the housing (IK10). Very good UV resistance.

- Orange PP (polypropylene) body, with transparent polycarbonate (PC) cover: Very good resistance to strong bases, good resistance to acids. For use on liquids up to 90 °C. Allows viewing constantly input and output power supply and thermostat set point. Reduced mechanical strength (IK8).



**Low differential electronic rod thermostat, with high corrosion resistance housing, specifically designed for surface treatment baths, and highly basic or acid corrosive liquids or environments.**



- Orange PP (polypropylene) body, with opaque orange PP (polypropylene) cover: Very good resistance to strong bases, good resistance to acids. For use in liquids up to 90 °C. Reduced mechanical strength (IK8).
- White PVDF body with opaque white PVDF cover: For use in liquid baths at temperatures above 90 °C and up to 110°C or strong oxidizing chemicals such as chrome electrolyte or nitric acid solution (HNO3). Reduced mechanical strength (IK8).

**Rod protection options (see also table below)**

- Stainless steel 316L-Ti without coating
- Stainless steel 316L, with FEP chemically deposited coating, thickness 0.2 to 0.4mm
- Stainless steel 316L, with PFA chemically deposited coating, thickness 0.2 to 0.4mm
- Stainless steel 316L, with PTFE chemically deposited coating, thickness 0.05 to 0.1mm
- Stainless steel 316L, with ETFE chemically deposited coating, thickness 0.2 to 0.4mm

**Main references with SS 316L rod, coated with shrinked PTFE**

Temperature ranges °C (°F)	Rod length (mm)	Black PA66 housing, crystal clear PC cover	Orange PP housing, crystal clear PC cover	Orange PP housing, orange opaque PP cover	White PVDF housing, White opaque PVDF cover	Differential* °C (°F)	Max temperature on probe °C (°F)
4-40°C (32-104°F)	450	YF52NCS04040451P	YF52PCS04040451P	YF52PPS04040451P	YF52VVS04040451P	0.8±0.2°C (1.5±0.4°F)	120°C (250°F)
30-90°C (85-195°F)	450	YF52NCS30090451P	YF52PCS30090451P	YF52PPS30090451P	YF52VVS30090451P	1±0.3°C (1.8±0.5°F)	120°C (250°F)
30-110°C (90-230°F)	450	YF52NCS30110451P	YF52PCS30110451P	YF52PPS30110451P	YF52VVS30110451P	1±0.3°C (1.8±0.5°F)	120°C (250°F)
4-40°C (32-104°F)	600	YF52NCS04040601P	YF52PCS04040601P	YF52PPS04040601P	YF52VVS04040601P	0.8±0.2°C (1.5±0.4°F)	120°C (250°F)
30-90°C (85-195°F)	600	YF52NCS30090601P	YF52PCS30090601P	YF52PPS30090601P	YF52VVS30090601P	1±0.3°C (1.8±0.5°F)	120°C (250°F)
30-110°C (90-230°F)	600	YF52NCS30110601P	YF52PCS30110601P	YF52PPS30110601P	YF52VVS30110601P	1±0.3°C (1.8±0.5°F)	120°C (250°F)

\* Differentials measured in laboratory conditions, in agitated liquid baths, with temperature change rates below 0.5°C/min.

**Reference modifications vs options**

Rod length			Rod protection coating						
300mm	800mm	1000mm	316L without coating	316L-Ti without coating	Titanium	316L+ FEP 0.2~0.4mm*	316L+ PFA 0.2~0.4mm*	316L+ PTFE 0.05~0.1mm*	316L+ ETFE 0.2~0.4mm*
XXXXXXXXXXXX30xx	XXXXXXXXXXXX80xx	XXXXXXXXXXXXA0xx	XXXXXXXXXXXXU	XXXXXXXXXXXXV	XXXXXXXXXXXXW	XXXXXXXXXXXXQ	XXXXXXXXXXXXR	XXXXXXXXXXXXS	XXXXXXXXXXXXT

\* MOQ 100 pieces.

Versions with °F printed knobs: replace S by T in the reference (7th character)

**Accessories**

1" BSPP Nut, 5mm thickness	Bracket for tank side mounting, thickness 10mm (Assembly made with 1" nut)	1" gasket for through wall waterproof mounting with 1" nut
Reference in PA66: 66YFHN1N	Reference in PA66: 66YFMB1N	Reference in FKM (Viton): 66YGA1F
Reference in PP: 66YFHN1P	Reference in PP: 66YFMB1P	
Reference in PVDF: 66YFHN1V	Reference in PVDF: 66YFMB1V	

Because of permanent improvement of our products, drawings, descriptions, features used on these data sheets are for guidance only and can be modified without prior advice





# Electronic thermostats, remote sensor, IP69K enclosure in PA66 and PC

Because of permanent improvement of our products, drawings, descriptions, features used on these data sheets are for guidance only and can be modified without prior advice

Type	Operation	Contact	Measurement	Ranges °C	Models
<b>Control</b>	<b>Electronic</b>	<b>SPNO or SPNC</b>	<b>Remote</b>		<b>Y2T2</b> <b>Y2T3</b>

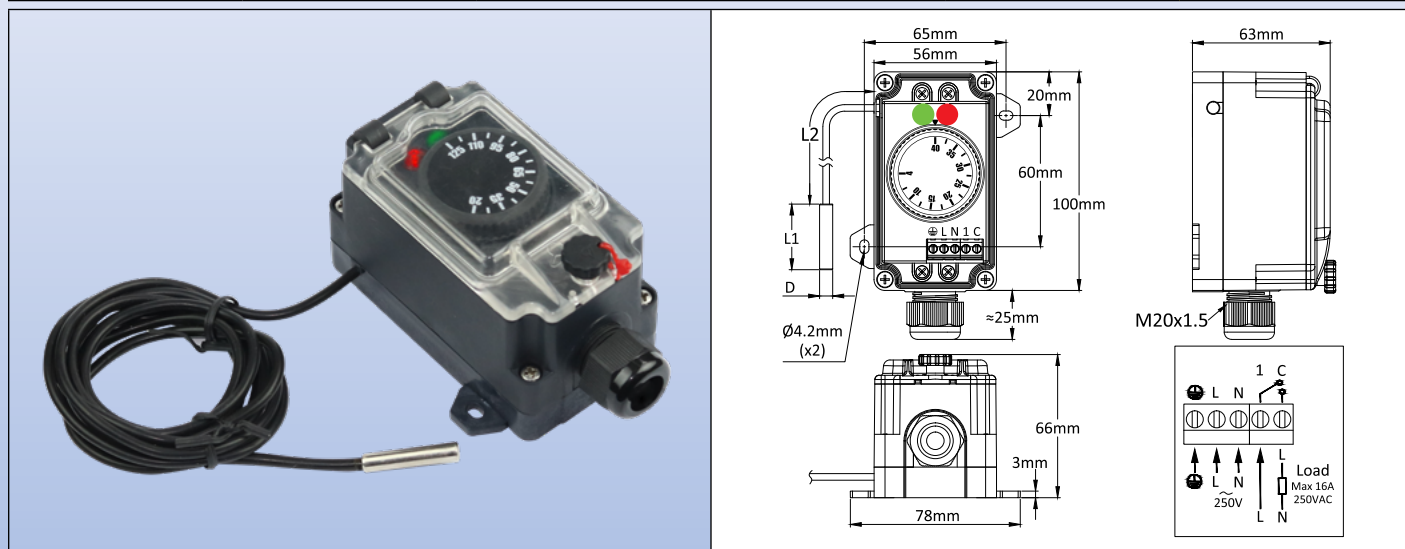

## Applications:

- Equipment requesting the highest resistance to water ingress.
- The transparent cover allows to visualize the set point and the 2 pilot lights.
- Very small differential.

### - Ultra compact enclosure

Temperature control with reduced differential, on-off action, in usual industrial applications and environments, not hazardous areas.

Use of electronic sensor allows **measurement at long distances**, which is not possible with bulb and capillary types.

**Housing:** Protection class IP69K upon EN60529 and DIN40050-9 (high pressure hot water, totally dust tight). Body in black PA66, fiber glass reinforced. Hinged transparent polycarbonate window, with gasket. It can be unscrewed by hand, and has holes for safety seals. IK10 shocks proof. UV resistant.

**Set point adjustment:** By °C printed knob. All types have an adjustable rotation limit system located inside the knob that allows reducing the set point adjustment span. °F printed knobs available as an option.

**Operation:** Microprocessor electronic thermostat.

**Sensing element:** NTC or Pt100 sensor, 2m standard cable length. Others lengths on request.

**Pilot lights:** One pilot light visualizes the thermostat contact output position. The second visualizes the power supply input.

**Set point adjustment ranges:** -35-35°C (-30+95°F); 0-10°C (32-50°F); 4-40°C (40-105°F); 30-90°C (85-195°F); 30-110°C (85-230°F); 20-125°C (68-260°F); 50-200°C (120-390°F); 50-300°C (120-570°F); 100-400°C (210-750°F); 100-500°C (210-930°F).

**Differential:** Differential is preset at the minimum value, but can be increased with a potentiometer located under the set point adjustment knob.

**Cable input and output:** one M20 cable glands, black PA66.

**Electrical connections:** Inside, on screw terminal. Electronic control power supply in 220-250V.

**Earthing:** Internal screw terminal.

**Mounting:** Wall mounting, by 2 legs with holes for screws dia. 4mm, 60 × 65mm distance.

**Identification:** Identification label on backside

**Contact:** SPST. 16A (2.6), 250VAC. Open or close on temperature rise. Model with contact closing on temperature rise is used for refrigeration. Version with contact opening on temperature rise is used for heating.

**Electrical life:** >100,000 cycles.

**Minimum storage temperature:** -35°C (-30°F)

**Maximum ambient temperature:** 60°C (140°F)

For more technical information see 2PE2N6 thermostat technical data sheet.



## Main references

References with SPNC, open on temperature rise contact, for heating control

Temperature adjustment ranges °C (°F)	Lowest differential °C (°F)	Temperature sensor type	Reference of the sensor connected in standard	References*
-35+35°C (-30+95°F)	0.5~0.8°C (0.9~1.4°F)	NTC (10Kohms @25°C)	TNR60030C20001F6	Y2T2GD035035NP2J
0-10°C (32-50°F)	0.25~0.33°C (0.4~0.6°F)	NTC (10Kohms @25°C)	TNR60030C20001F6	Y2T2GD000010NP2J
4-40°C (40-105°F)	0.25~0.33°C (0.4~0.6°F)	NTC (10Kohms @25°C)	TNR60030C20001F6	Y2T2GD004040NP2J
30-90°C (85-195°F)	0.5~0.8°C (0.9~1.4°F)	NTC (10Kohms @25°C)	TNR60030C20001F6	Y2T2GD030090NP2J
30-110°C (85-230°F)	0.5~0.8°C (0.9~1.4°F)	NTC (10Kohms @25°C)	TNR60030C20001F6	Y2T2GD030110NP2J
20-125°C (68-260°F)	0.5~0.8°C (0.9~1.4°F)	NTC (10Kohms @25°C)	TNR60030C20001F6	Y2T2GD020125NP2J
30-110°C (85-230°F)	0.5~0.8°C (0.9~1.4°F)	Pt100	TSR50030I2000BK6	Y2T3GD030110PP2J
50-200°C (120-390°F)	0.5~0.8°C (0.9~1.4°F)	Pt100	TSR50030I2000BK6	Y2T3GD050200PP2J
50-300°C (120-570°F)	1~1.3°C (1.8~2.3°F)	Pt100	TSS40050I2000BK6	Y2T3GD050300RF2J
100-400°C (210-750°F)	1~1.3°C (1.8~2.3°F)	Pt100	TSS40050I2000BK6	Y2T3GD0A0400RF2J
100-500°C (210-930°F)	1~1.3°C (1.8~2.3°F)	Pt100	TSS40050I2000BK6**	Y2T3GD0A0500RF2J**

References with SPNO, close on temperature rise contact, for cooling or fan control

Temperature adjustment ranges °C (°F)	Lowest differential °C (°F)	Temperature sensor type	Reference of the sensor connected in standard	Reference*
-35+35°C (-30+95°F)	0.5~0.8°C (0.9~1.4°F)	NTC (10Kohms @25°C)	TNR60030C20001F6	Y2T2GC035035NP2J
0-10°C (32-50°F)	0.25~0.33°C (0.4~0.6°F)	NTC (10Kohms @25°C)	TNR60030C20001F6	Y2T2GC000010NP2J
4-40°C (40-105°F)	0.25~0.33°C (0.4~0.6°F)	NTC (10Kohms @25°C)	TNR60030C20001F6	Y2T2GC004040NP2J
30-90°C (85-195°F)	0.5~0.8°C (0.9~1.4°F)	NTC (10Kohms @25°C)	TNR60030C20001F6	Y2T2GC030090NP2J
30-110°C (85-230°F)	0.5~0.8°C (0.9~1.4°F)	NTC (10Kohms @25°C)	TNR60030C20001F6	Y2T2GC030110NP2J
20-125°C (68-260°F)	0.5~0.8°C (0.9~1.4°F)	NTC (10Kohms @25°C)	TNR60030C20001F6	Y2T2GC020125NP2J
30-110°C (85-230°F)	0.5~0.8°C (0.9~1.4°F)	Pt100	TSR50030I2000BK6	Y2T3GC030110PP2J
50-200°C (120-390°F)	0.5~0.8°C (0.9~1.4°F)	Pt100	TSR50030I2000BK6	Y2T3GC050200PP2J
50-300°C (120-570°F)	1~1.3°C (1.8~2.3°F)	Pt100	TSS40050I2000BK6	Y2T3GC050300RF2J
100-400°C (210-750°F)	1~1.3°C (1.8~2.3°F)	Pt100	TSS40050I2000BK6	Y2T3GC0A0400RF2J
100-500°C (210-930°F)	1~1.3°C (1.8~2.3°F)	Pt100	TSS40050I2000BK6**	Y2T3GC0A0500RF2J**



\*F printing: replace last character (J) by K

\* Character 15 gives the sensor cable length (2=2m, 3=3m, 4= 4m)

\*\* Maximum temperature on sensor probe 450°C

## Standard temperature sensors incorporated inside controls

(References provided hereunder allow to purchase them separately)

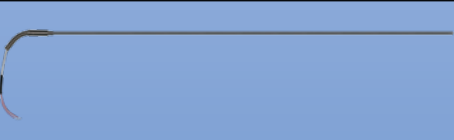
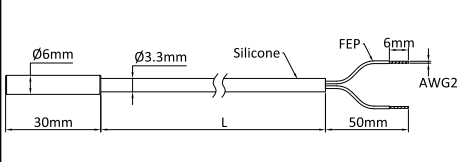
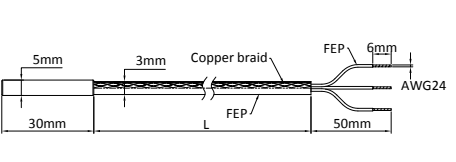
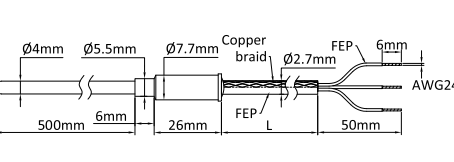
NTC Thermistor	Pt100, 3 wires, 200°C	Pt100, 3 wires, 400°C
		
		
<p><b>Value:</b> 10Kohms @25°C, B= 3380</p> <p><b>Accuracy:</b> +/-1% on R25 e/+/-1% on B</p> <p><b>Temperature range:</b> -20°C+120°C</p> <p><b>Probe:</b> Nickel plated copper, 6 x 30mm</p> <p><b>Cable:</b> AWG24, FEP + silicone insulation, dia. 3.3mm, standard length 2m. Character 10 in the reference provides sensor cable length in meters (2=2m, 3= 3m, 4=4m)</p>	<p><b>Accuracy and tolerances:</b> Class B, ±0.3°C @ 0°C. (±0.12 Ω @ 0°C).</p> <p><b>Temperature range:</b> -50°C, +200°C</p> <p><b>Probe:</b> Stainless Steel 304, dia. 5mm x 30mm</p> <p><b>Cable:</b> 3 x AWG24, FEP insulation, + metal braid + FEP, T 200°C, dia. 3mm, standard length 2m. Character 10 in the reference provides sensor cable length in meters (2=2m, 3= 3m, 4=4m)</p>	<p><b>Accuracy and tolerances:</b> Class B, ±0.3°C @ 0°C. (±0.12 Ω @ 0°C).</p> <p><b>Probe temperature range:</b> -50°C, +400°C</p> <p><b>Probe:</b> Stainless Steel 304, dia. 4mm x 500mm</p> <p><b>Cable:</b> 3 x AWG24, FEP insulation, + metal braid + FEP, T 200°C, dia. 2.7mm, standard length 2m. Character 10 in the reference provides sensor cable length in meters (2=2m, 3= 3m, 4=4m)</p>
<b>Reference:</b> TNR60030C20001F6	<b>Reference:</b> TSR50030I2000BK6	<b>Reference:</b> TSS40050I2000BK6



# Manual reset electronic thermostat, for room temperature control



Because of permanent improvement of our products, drawings, descriptions, features used on these data sheets are for guidance only and can be modified without prior advice

# Manual reset electronic room adjustable limiter



Because of permanent improvement of our products, drawings, descriptions, features used on these data sheets are for guidance only and can be modified without prior advice

Enclosure	Type	Operation	Contact	Measurement	Ranges °C	Models
IP65, IK10	Limiter	Electronic	SPNO or SPNC	Ambient		<b>Y1B2L</b> <b>Y1A2L</b>
Material						
Aluminum						

<p>Y1B2L: External adjustment and external reset (With pilot light)</p>		<p>Y1A2L: Internal adjustment and reset (Without pilot light)</p>	

## Applications:

- Wall mounting for indoor or outdoor **high temperature alarm** of cold rooms.
- **High temperature alarm** of industrial or commercial premises.
- Outdoor temperature control of antifreeze heaters.
- **High temperature alarm** of green houses and livestock stables.

**Housing:** Aluminum, IP65, IK10. Mounted on a SUS304 stainless steel wall mounting plate which keeps the temperature sensing element away from the wall. Grey RAL7032 epoxy painting. Stainless steel captive cover screws. Captive aluminum lid.

**Operation:** Microprocessor manual reset electronic limiter, with adjustable set point.

**Adjustment ranges:** -35-35°C (-30+95°F), 0-10°C (32-50°F), 4-40°C (40-105°F).

**Set point adjustment:** By °C printed knob. All types have an adjustable rotation limit system located inside the knob that allows reducing the set point adjustment span. Types with external adjustment have a transparent window. This device allows seeing the pilot light and the knob position. °F values are available as an option.

**Reset:** by push button switch beside the knob.

**Sensing element:** NTC probe, mounted on the side of plastic housing.

**Cable input and output:** Two M20 cable glands, Black PA66. Internal electrical connection on screw terminals. 2 phases power supply (Line+ Neutral, 220~250V, 50Hz~60Hz) are mandatory.

**Earthing:** Internal and external screw terminal.

**Pilot light:** Allow to visualize thermostat contact output position. Standard for all models with transparent window. Non Standard and on special request only for models with plain aluminum cover.

**Mounting:** Wall mounting, by 4 holes for screws dia. 4 to 5 mm, 94 x 92 mm distance.

**Identification:** Metallic identification label, riveted.

**Contact:** SPST. 16A (2.6), 250VAC. Open or close on temperature rise. The version with contact closing on temperature rise is used to switch on an alarm. The version with contact opening on temperature rise is used to switch-off heating.

**Electrical life:** >100,000 cycles.

**Minimum storage temperature:** -35°C (-30°F)

**Maximum ambient temperature:** 60°C (140°F)

For more technical information ask 2PE2N6 thermostat technical data sheet (catalog 1)

# Manual reset electronic room adjustable limiter



## Main references

Temperature adjustment ranges °C (°F)	Open on temperature rise contact		Close on temperature rise contact	
	References with external adjustment	References with internal adjustment	References with external adjustment	References with internal adjustment
-35-35°C (-30+95°F)	Y1B2LN6F235035AJ	Y1A2LN6F235035AJ	Y1B2LN6G235035AJ	Y1A2LN6G235035AJ
4-40°C (40-105°F)	Y1B2LN6F204040AJ	Y1A2LN6F204040AJ	Y1B2LN6G204040AJ	Y1A2LN6G204040AJ

°F printing: replace last character (J) by K

## Knob printings

°C Printing		°F Printing	
-35+35°C	4-40°C	-30+95°F	40-105°F

Because of permanent improvement of our products, drawings, descriptions, features used on these data sheets are for guidance only and can be modified without prior advice



# Adjustable manual reset electronic room limiters



Because of permanent improvement of our products, drawings, descriptions, features used on these data sheets are for guidance only and can be modified without prior advice

Enclosure	Type	Operation	Contact	Measurement	Ranges °C	Models
IP66, IK10	Limiter	Electronic	SPNO or SPNC	Ambient		<b>YF63NC</b> <b>YF65NC</b>
Material PA66 & PC						

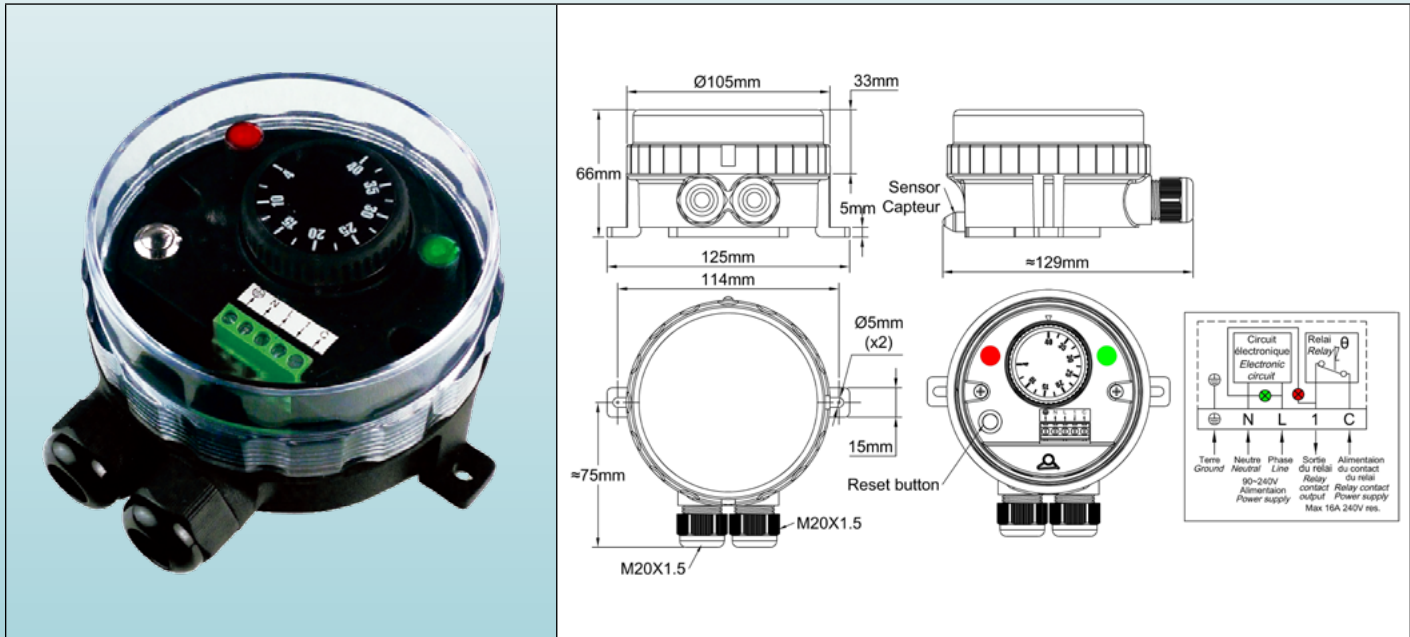

## Applications:

- **Equipment requesting a very strong resistance to water ingress. The transparent cover allows to visualize the set point and the 2 pilot lights.**
- Wall mounting for indoor or outdoor **high temperature alarm** of cold rooms.
- **High temperature alarm** of industrial or commercial premises.
- Outdoor temperature alarm of antifreeze heaters.
- **High temperature alarm** of green houses and livestock stables.

**Housing:** Protection class IP 66 upon EN 60529 (waterproof spray water under high pressure and sea splashes, totally dust tight). Body in black PA66, fiber glass reinforced. The transparent polycarbonate cover can be unscrewed by hand, but it is also possible to use a hook spanner. Mechanical impact resistance: IK10. High UV resistance.

**Set point adjustment:** By °C printed knob. All types have an adjustable rotation limit system located inside the knob that allows reducing the set point adjustment span. °F printed knobs available as an option.

**Operation:** Microprocessor electronic thermostat.

**Sensing element:** NTC probe, mounted on the top of the plastic housing.

**Pilot lights:** One pilot light visualizes the thermostat contact output position. The other visualizes the power supply input. Phase and line 230V power supply is mandatory for these pilot lights.

**Set point adjustment ranges:** -35-35°C (-30+95°F), 0-10°C (32-50°F), 4-40°C (40-105°F).

**Reset:** By push button switch beside the knob.

**Cable input and output:** Two M20 cable glands, built-in black PA66.

**Electrical connections:** Inside, on screw terminal connection block. It is possible to connect 2 wires 1.5mm<sup>2</sup> on each terminal.

**Earthing:** Internal screw terminal.

**Mounting:** Wall mounting, by 2 legs with holes for screws dia. 4 to 5 mm, 114 mm distance.

**Identification:** Identification label on backside

**Contact:** SPST. 16A (2.6), 250VAC. Open or close on temperature rise. Model with contact closing on temperature rise is used to switch on an alarm. Version with contact opening on temperature rise is used to switch off heating.

**Electrical life:** >100,000 cycles.

**Minimum storage temperature:** -35°C (-30°F)

**Maximum ambient temperature:** 60°C (140°F)

For more technical information ask 2PE2N6 thermostat technical data sheet.

# Adjustable manual reset electronic room limiters



## Main references

Temperature adjustment ranges °C (°F)	References with SPNC, open on temperature rise contact	References with SPNO, close on temperature rise contact
-35+35°C (-30+95°F)	YF63NC350350000J	YF65NC350350000J
0+10°C (32-50°F)	YF63NC000100000J	YF65NC000100000J
+4+40°C (40-105°F)	YF63NC040400000J	YF65NC040400000J

°F Printing: replace last character (J) by K

## Knob printings

°C Printing			°F Printing		
-35+35°C	0-10°C	4-40°C	-30+95°F	32-50°F	40-105°F

Because of permanent improvement of our products, drawings, descriptions, features used on these data sheets are for guidance only and can be modified without prior advice



# Manual reset electronic thermostat, with Remotel sensor, for temperature control



Because of permanent improvement of our products, drawings, descriptions, features used on these data sheets are for guidance only and can be modified without prior advice

# Manual reset electronic adjustable limiter, remotel sensor



Because of permanent improvement of our products, drawings, descriptions, features used on these data sheets are for guidance only and can be modified without prior advice

Enclosure	Type	Operation	Contact	Measurement	Ranges °C	Models
IP65, IK10	Limiter	Electronic	SPNO or SPNC	Remotel		<h2>Y1I2L Y1G2L</h2>
Material						
Aluminium						

<p>Y1I2L: External adjustment and external reset (With pilot light)</p>		<p>Y1G2L: Internal adjustment and reset (Without pilot light)</p>	

## Applications:

Temperature **high limit**, in usual industrial application and environment, non-hazardous areas.

Internal adjustment is convenient for products that must not be frequently adjusted.

Use of electronic sensor allows **measurement at long distances**, which is not possible with bulb and capillary types.

**Housing:** Aluminum, IP65, IK10. Mounted on a SUS304 stainless steel wall mounting plate which keeps temperature sensing element away from the wall. Grey RAL7032 epoxy painting. Stainless steel captive cover screws. Captive aluminum lid.

**Operation:** Microprocessor manual reset electronic limiter, with adjustable set point.

**Adjustment ranges:** -35-35°C (-30+95°F); 0-10°C (32-50°F); 4-40°C (40-105°F); 30-90°C (85-195°F); 30-110°C (85-230°F); 50-200°C (120-390°F); 50-300°C (120-570°F); 100-400°C (210-750°F); 100-500°C (210-930°F).

**Set point adjustment:** By °C printed knob. All types have an adjustable rotation limit system located inside the knob that allows reducing the set point adjustment span. Types with external adjustment have a transparent window. This device allows seeing the pilot light and the knob position. °F values are available in option.

**Reset:** by push button switch beside the knob

**Sensing element:** NTC or Pt100 sensor. The sensor cable is protected by a stainless steel corrugated pipe terminated by a silicone tip. A plastic cap plug provided as standard accessory allows locking the flexible metal conduit inside a pocket (See pockets in the accessories section). Standard cable length 2m. Other lengths on request.

**Cable input and output:** Two M20 cable gland, Black PA66. Internal electrical connection on screw terminals. 2 phases power supply (Line+ Neutral, 220~250V, 50Hz~60Hz) are mandatory.

**Earthing:** Internal and external screw terminal.

**Pilot light:** Allow to visualize thermostat contact output position. Standard for all models with transparent window.

Non Standard and on special request only for models with plain aluminum cover.

**Mounting:** Wall mounting, by 4 holes for screws dia. 4 to 5mm, 94 × 92mm distance

**Identification:** Metallic identification label, riveted.

**Contact:** SPST. 16A (2.6), 250VAC. Open or close on temperature rise. Contact close on temperature rise model is used to switch on alarm. Contact open on temperature rise version is used to switch off heating.

**Electrical life:** >100,000 cycles.

**Minimum Storage temperature:** -35°C (-30°F)

**Maximum ambient temperature:** 60°C (140°F)

For more technical information see 2PE2N6 thermostat technical data sheet



## Main references

Temperature adjustment ranges °C (°F)	Temperature sensor	Open on temperature rise contact		Close on temperature rise contact	
		References with external adjustment	References with internal adjustment	References with external adjustment	References with internal adjustment
-35+35°C (-30+95°F)	NTC (10KOhms @25°C)	Y1I2LN6F2350352J	Y1G2LN6F2350352J	Y1I2LN6G2350352J	Y1G2LN6G2350352J
0-10°C (32-50°F)	NTC (10KOhms @25°C)	Y1I2LN6F2000102J	Y1G2LN6F2000102J	Y1I2LN6G2000102J	Y1G2LN6G2000102J
4-40°C (40-105°F)	NTC (10KOhms @25°C)	Y1I2LN6F2040402J	Y1G2LN6F2040402J	Y1I2LN6G2040402J	Y1G2LN6G2040402J
30-90°C (85-195°F)	NTC (10KOhms @25°C)	Y1I2LN6F2300902J	Y1G2LN6F2300902J	Y1I2LN6G2300902J	Y1G2LN6G2300902J
30-110°C (85-230°F)	NTC (10KOhms @25°C)	Y1I2LN6F2301102J	Y1G2LN6F2301102J	Y1I2LN6G2301102J	Y1G2LN6G2301102J
50-200°C (120-390°F)	Pt100	Y1I2LP6F2502002J	Y1G2LP6F2502002J	Y1I2LP6F2502002J	Y1G2LP6F2502002J
50-300°C (120-570°F)	Pt100	Y1I2LP6F2503002J	Y1G2LP6F2503002J	Y1I2LP6F2503002J	Y1G2LP6F2503002J
100-400°C (210-750°F)	Pt100	Y1I2LP6F2A04002J	Y1G2LP6F2A04002J	Y1I2LP6F2A04002J	Y1G2LP6F2A04002J
100-500°C (210-930°F)	Pt100	Y1I2LP6F2A05002J	Y1G2LP6F2A05002J	Y1I2LP6F2A05002J	Y1G2LP6F2A05002J

°F printing: replace last character (J) by K  
Character 15 gives the sensor cable length (2m)

## Knob printings

°C Printing				
-35+35°C	0-10°C	4-40°C	30-90°C	30-110°C
50-200°C	50-300°C	100-400°C	100-500°C	
°F Printing				
-30+95°F	32-50°F	40-105°F	85-195°F	85-230°F
120-390°F	120-570°F	210-750°F	210-930°F	

Because of permanent improvement of our products, drawings, descriptions, features used on these data sheets are for guidance only and can be modified without prior advice



# Remote sensor adjustable manual reset electronic limiters



Because of permanent improvement of our products, drawings, descriptions, features used on these data sheets are for guidance only and can be modified without prior advice

Enclosure	Type	Operation	Contact	Measurement	Ranges °C	Models
IP66, IK10	Limiters	Electronic	SPNO or SPNC	Remotel		<b>YF93NC</b> <b>YF95NC</b>
Material PA66 & PC						

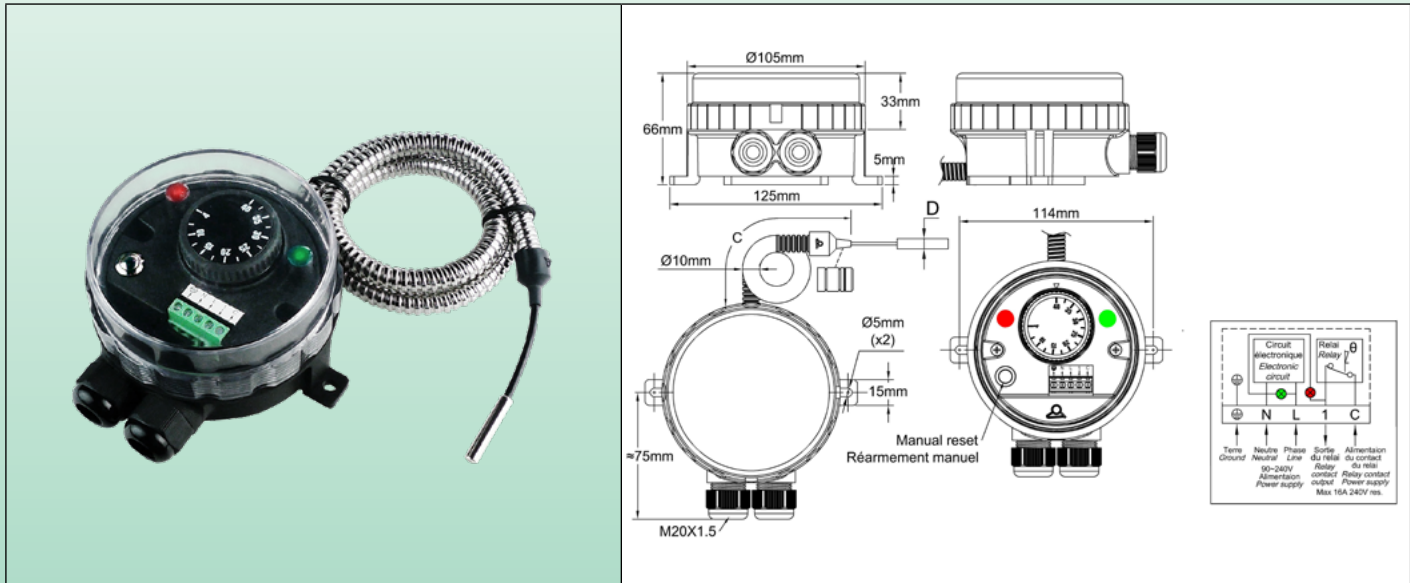

## Applications:

- **Equipment requesting a very strong resistance to water ingress. The transparent cover allows to visualize the set point and the 2 pilot lights.**

- Use of electronic sensor allows **measurement at long distances**, which is not possible with bulb and capillary types.
- Manual reset allows the use as **high temperature alarm**

**Housing:** Protection class IP 66 upon EN 60529 (waterproof spray water under high pressure and sea splashes, totally dust tight). Body in black PA66, fiber glass reinforced. The transparent polycarbonate cover can be unscrewed by hand, but it is also possible to use a hook spanner.

**Set point adjustment:** By °C printed knob. All types have an adjustable rotation limit system located inside the knob that allows reducing the set point adjustment span. °F printed knobs available as an option

**Operation:** Microprocessor electronic thermostat.

**Sensing element:** NTC or Pt100 sensor, diameter D = 5mm. The sensor cable is protected by a stainless steel corrugated pipe terminated by a silicone tip. A plastic cap plug provided as standard accessory allows locking the flexible metal conduit inside a pocket (See pockets in the accessories section). Standard cable length 2m. Other lengths on request.

**Pilot lights:** One pilot light visualizes the thermostat contact output position. The other visualizes the power supply input. Phase and line 230V power supply is mandatory for these pilot lights.

**Set point adjustment ranges:** -35-35°C (-30+95°F); 0-10°C (32-50°F); 4-40°C (40-105°F); 30-90°C (85-195°F); 30-110°C (85-230°F); 50-200°C (120-390°F); 50-300°C (120-570°F); 100-400°C (210-750°F); 100-500°C (210-930°F).

**Manual reset button:** located beside the knob

**Cable input and output:** Two M20 cable glands, built-in black PA66.

**Electrical connections:** Inside, on screw terminal connection block. It is possible to connect 2 wires 1.5mm<sup>2</sup> on each terminal.

**Earthing:** Internal screw terminal.

**Mounting:** Wall mounting, by 2 legs with holes for screws dia. 4 to 5mm, 114mm distance

**Identification:** Identification label on backside

**Contact:** SPST. 16A (2.6), 250VAC. Open or close on temperature rise.

Model with contact closing on temperature rise is used to switch on an alarm. Version with contact opening on temperature rise is used to switch off heating.

**Electrical life:** >100,000 cycles.

**Minimum storage temperature:** -35°C (-30°F)

**Maximum ambient temperature:** 60°C (140°F)

For more technical information see 2PE2N6 thermostat technical data sheet.

# Remote sensor adjustable manual reset electronic limiters



## Main references

Temperature adjustment ranges °C (°F)	Temperature sensor	References with SPNC, open on temperature rise contact	References with SPNO, close on temperature rise contact
-35+35°C (-30+95°F)	NTC (10KOhms @25°C)	YF93NC350352051J	YF95NC350352051J
0-10°C (32-50°F)	NTC (10KOhms @25°C)	YF93NC000102051J	YF95NC000102051J
4-40°C (40-105°F)	NTC (10KOhms @25°C)	YF93NC040402051J	YF95NC040402051J
30-90°C (85-195°F)	NTC (10KOhms @25°C)	YF93NC000902051J	YF95NC000902051J
30-110°C (85-230°F)	NTC (10KOhms @25°C)	YF93NC301102051J	YF95NC301102051J
50-200°C (120-390°F)	Pt100	YF93NC502002051J	YF95NC502002051J
50-300°C (120-570°F)	Pt100	YF93NC503002051J	YF95NC503002051J
100-400°C (210-750°F)	Pt100	YF93NCA04002051J	YF95NCA04002051J
100-500°C (210-930°F)	Pt100	YF93NCA05002051J	YF95NCA05002051J

\*F printing: replace last character (J) by K  
Character 12 gives the sensor cable length (2m)

## Knob printings

°C Printing				
-35+35°C	0-10°C	4-40°C	30-90°C	30-110°C
50-200°C	50-300°C	100-400°C	100-500°C	
°F Printing				
-30+95°F	32-50°F	40-105°F	85-195°F	85-230°F
120-390°F	120-570°F	210-750°F	210-930°F	

Because of permanent improvement of our products, drawings, descriptions, features used on these data sheets are for guidance only and can be modified without prior advice



# Adjustable electronic manual reset limiters for immersion heaters

Because of permanent improvement of our products, drawings, descriptions, features used on these data sheets are for guidance only and can be modified without prior advice

Enclosure	Type	Operation	Contact	Measurement	Ranges °C	Models
IP66, IK10	Manual reset	Electronic	SPNC	Immersion heater	+110°C +4°C	<b>YF83NC</b>
Material						
PA66 & PC						

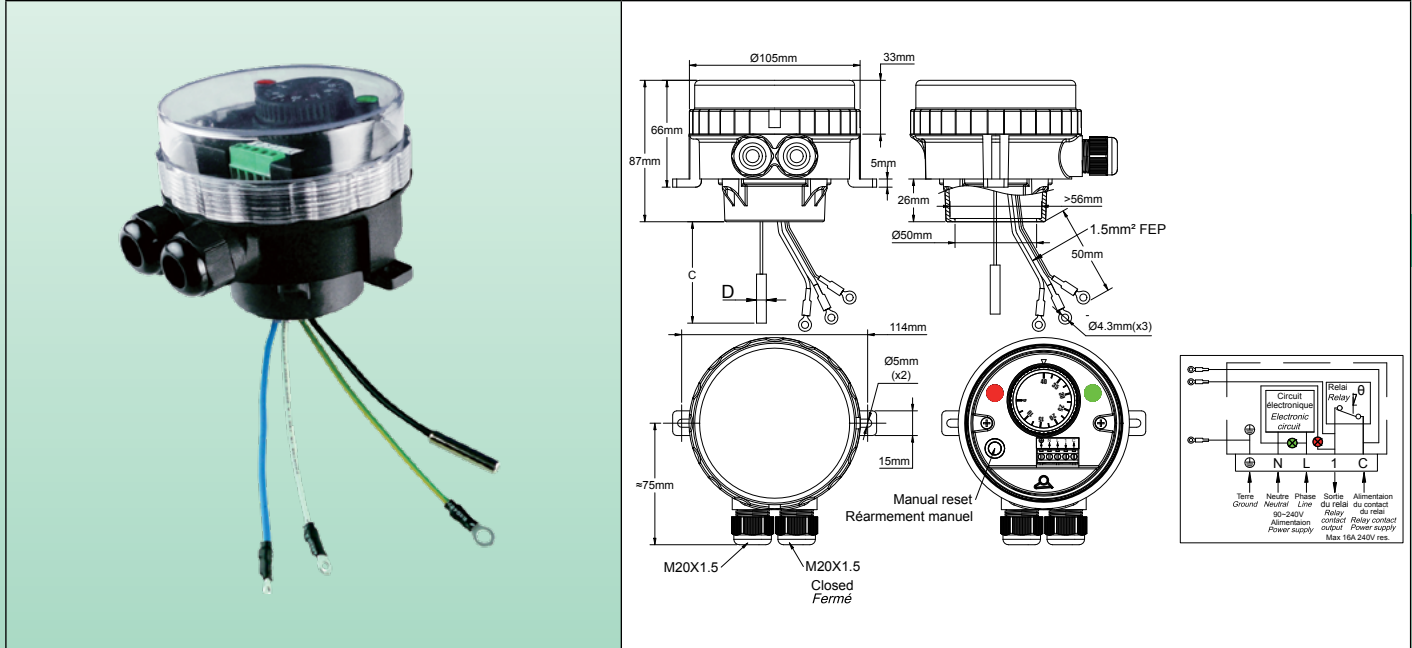

## Applications:

- Equipment requesting a very strong resistance to water ingress. The transparent cover allows to visualize the set point and the 2 pilot lights

Fully wired electronic temperature control sub assembly for direct mounting on immersion heater elements, 1"1/2 or M45x2 with double thread or rotation ring.

Applications in high temperature safety in usual industrial applications and environments, non-hazardous areas.

**Housing:** Protection class IP 66 upon EN 60529 (waterproof spray water under high pressure and sea splashes, totally dust tight). Body in black PA66, fiber glass reinforced. The transparent polycarbonate cover can be unscrewed by hand, but it is also possible to use a hook spanner. A removable adapter is screwed at the bottom of the enclosure. It fits the usual immersion heater fittings. Mechanical impact resistance: IK10. High UV resistance.

**Set point adjustment:** By °C printed knob. All types have an adjustable rotation limit system located inside the knob that allows reducing the set point adjustment span. °F printed knobs available as an option.

**Operation:** Microprocessor electronic thermostat, manual reset high temperature limiter

**Set point adjustment ranges:** 4-40°C (40-105°F); 30-90°C (85-195°F); 30-110°C (85-230°F).

**Differential:** Manual reset differential is preset at the minimum value, but can be increased with a potentiometer located under the set point adjustment knob.

**Sensing element:** The 5 × 30mm NTC sensor (10KOhms @25°C) goes out by the bottom of the enclosure to fit in the immersion heater pocket.

**Pilot lights:** One pilot light visualizes the thermostat contact output position. The other visualizes the power supply input. Phase and line 230V power supply is mandatory for these pilot lights.

**Cable input and output:** Two M20 cable glands, built-in black PA66. One of them is closed.

**Electrical connections:** Inside, on screw terminal connection block.

**Earthing:** Internal screw terminal and 1.5mm² FEP insulated wire with round hole terminals for the immersion heater.

**Mounting:** By the immersion heater thread or by 2 legs with holes for screws dia. 4 to 5mm, 114mm distance.

**Identification:** Identification label on backside.

**Contact:** SPNC. 16A (2.6), 250VAC. Contact open on temperature rise.

**Electrical life:** >100,000 cycles.

**Minimum storage temperature:** -35°C (-30°F)

**Maximum ambient temperature:** 60°C (140°F)

For more technical information ask 2PE2N6 thermostat technical data sheet.



## Main references

Temperature adjustment ranges °C (°F)	References with SPNC contact, open on temperature rise	NTC sensor cable length (C, mm)	Minimum differential °C (°F)
4-40°C (40-105°F)	YF83NC04040118UJ	110	0.5~0.8°C (0.9~1.4°F)
4-40°C (40-105°F)	YF83NC04040178UJ	170	0.5~0.8°C (0.9~1.4°F)
4-40°C (40-105°F)	YF83NC04040238UJ	230	0.5~0.8°C (0.9~1.4°F)
4-40°C (40-105°F)	YF83NC04040308UJ	300	0.5~0.8°C (0.9~1.4°F)
4-40°C (40-105°F)	YF83NC04040458UJ	450	0.5~0.8°C (0.9~1.4°F)
4-40°C (40-105°F)	YF83NC04040608UJ	600	0.5~0.8°C (0.9~1.4°F)
30-90°C (85-195°F)	YF83NC30090118UJ	110	0.5~0.8°C (0.9~1.4°F)
30-90°C (85-195°F)	YF83NC30090178UJ	170	0.5~0.8°C (0.9~1.4°F)
30-90°C (85-195°F)	YF83NC30090238UJ	230	0.5~0.8°C (0.9~1.4°F)
30-90°C (85-195°F)	YF83NC30090308UJ	300	0.5~0.8°C (0.9~1.4°F)
30-90°C (85-195°F)	YF83NC30090458UJ	450	0.5~0.8°C (0.9~1.4°F)
30-90°C (85-195°F)	YF83NC30090608UJ	600	0.5~0.8°C (0.9~1.4°F)
30-110°C (85-230°F)	YF83NC30110118UJ	110	0.5~0.8°C (0.9~1.4°F)
30-110°C (85-230°F)	YF83NC30110178UJ	170	0.5~0.8°C (0.9~1.4°F)
30-110°C (85-230°F)	YF83NC30110238UJ	230	0.5~0.8°C (0.9~1.4°F)
30-110°C (85-230°F)	YF83NC30110308UJ	300	0.5~0.8°C (0.9~1.4°F)
30-110°C (85-230°F)	YF83NC30110458UJ	450	0.5~0.8°C (0.9~1.4°F)
30-110°C (85-230°F)	YF83NC30110608UJ	600	0.5~0.8°C (0.9~1.4°F)

\*F printing: replace last character (J) by K

## Knob printings

°C Printing		
4-40°C	30-90°C	30-110°C
°F Printing		
40-105°F	85-195°F	85-230°F

Because of permanent improvement of our products, drawings, descriptions, features used on these data sheets are for guidance only and can be modified without prior advice



Because of permanent improvement of our products, drawings, descriptions, features used on these data sheets are for guidance only and can be modified without prior advice

# Manual reset electronic thermostat, rod or pipe mounting sensor, for temperature control



Because of permanent improvement of our products, drawings, descriptions, features used on these data sheets are for guidance only and can be modified without prior advice



# Manual reset electronic rod limiter



Because of permanent improvement of our products, drawings, descriptions, features used on these data sheets are for guidance only and can be modified without prior advice

Enclosure	Type	Operation	Contact	Measurement	Ranges °C	Models
IP65, IK10	Limiter	Electronic	SPNO or SPNC	Rod		<b>Y1S2L</b> <b>Y1R2L</b>
Material						
Aluminum						

<p>Y1S2L: External adjustment and external reset (With pilot light)</p>		<p>Y1R2L: Internal adjustment and reset (Without pilot light)</p>	

## Applications:

These rod limiters with **electronic sensor with adjustable set point** can be installed inside pockets as immersion high temperature limits on pipelines and containers, and for monitoring temperature in air ducts, in usual industrial applications and environments. (Not suitable for hazardous areas).  
Internal adjustment is convenient for products that must not be frequently adjusted.

**Housing:** Aluminum, IP65, IK10. Grey RAL7032 epoxy painting. Stainless steel captive cover screws. Captive aluminum lid.

**Operation:** Microprocessor manual reset electronic limiter, with adjustable set point.

**Adjustment ranges:** -35-35°C (-30+95°F); 0-10°C (32-50°F); 4-40°C (40-105°F); 30-90°C (85-195°F); 30-110°C (85-230°F); 50-200°C (120-390°F); 50-300°C (120-570°F); 100-400°C (210-750°F); 100-500°C (210-930°F).

**Set point adjustment:** By °C printed knob. All types have an adjustable rotation limit system located inside the knob that allows reducing the set point adjustment span. Types with external adjustment have a transparent window. This device allows seeing the pilot light and the knob position. °F values are available as an option.

**Reset:** by push button switch beside the knob

**Sensing element:** NTC or Pt100 sensor located at the end of a dia.8mm stainless steel rod. An increased diameter under the thermostat head allows mounting pockets, coolers or brackets (See pockets in the accessories section)

**Cable input and output:** Two M20 cable glands, Black PA66. Internal electrical connection on screw terminals. 2 phases power supply (Line+ Neutral, 220~250V, 50Hz~60Hz) are mandatory.

**Earthing:** Internal and external screw terminal.

**Pilot light:** Allow to visualize thermostat contact output position. Standard for all models with transparent window. Non Standard and on special request only for models with plain aluminum cover.

**Identification:** Metallic identification label, riveted.

**Contact:** SPST. 16A (2.6), 250VAC. Open or close on temperature rise.

The version with contact closing on temperature rise is used to switch on an alarm. The version with contact opening on temperature rise is used to switch-off heating.

**Electrical life:** >100,000 cycles.

**Minimum storage temperature:** -35°C (-30°F)

**Maximum ambient temperature:** 60°C (140°F)

For more technical information ask 2PE2N6 thermostat technical data sheet (catalog 1)



## Main references (Rod dia. 8mm, open on temperature rise contact)

Temperature adjustment ranges °C (°F)	References with external adjustment	References with internal adjustment	Temperature sensor	Rod length* (L, mm)	Differential °C (°F)
-35-35°C (-30+95°F)	Y1S2PN6F235035BJ	Y1R2PN6F235035BJ	NTC (10KOhms @25°C)	90	0.5~0.8°C (0.9~1.4°F)
-35-35°C (-30+95°F)	Y1S2PN6F235035CJ	Y1R2PN6F235035CJ	NTC (10KOhms @25°C)	110	0.5~0.8°C (0.9~1.4°F)
-35-35°C (-30+95°F)	Y1S2PN6F235035DJ	Y1R2PN6F235035DJ	NTC (10KOhms @25°C)	170	0.5~0.8°C (0.9~1.4°F)
-35-35°C (-30+95°F)	Y1S2PN6F235035EJ	Y1R2PN6F235035EJ	NTC (10KOhms @25°C)	230	0.5~0.8°C (0.9~1.4°F)
-35-35°C (-30+95°F)	Y1S2PN6F235035FJ	Y1R2PN6F235035FJ	NTC (10KOhms @25°C)	300	0.5~0.8°C (0.9~1.4°F)
-35-35°C (-30+95°F)	Y1S2PN6F235035GJ	Y1R2PN6F235035GJ	NTC (10KOhms @25°C)	450	0.5~0.8°C (0.9~1.4°F)
0-10°C (32-50°F)	Y1G2PN6F2000102J	Y1R2PN6F200010CJ	NTC (10KOhms @25°C)	110	0.5~0.8°C (0.9~1.4°F)
0-10°C (32-50°F)	Y1S2PN6F200010CJ	Y1R2PN6F200010EJ	NTC (10KOhms @25°C)	230	0.5~0.8°C (0.9~1.4°F)
0-10°C (32-50°F)	Y1S2PN6F200010EJ	Y1R2PN6F200010FJ	NTC (10KOhms @25°C)	300	0.5~0.8°C (0.9~1.4°F)
0-10°C (32-50°F)	Y1S2PN6F200010FJ	Y1R2PN6F200010GJ	NTC (10KOhms @25°C)	450	0.5~0.8°C (0.9~1.4°F)
4-40°C (40-105°F)	Y1S2PN6F204040BJ	Y1R2PN6F204040BJ	NTC (10KOhms @25°C)	90	0.5~0.8°C (0.9~1.4°F)
4-40°C (40-105°F)	Y1S2PN6F204040CJ	Y1R2PN6F204040CJ	NTC (10KOhms @25°C)	110	0.5~0.8°C (0.9~1.4°F)
4-40°C (40-105°F)	Y1S2PN6F204040DJ	Y1R2PN6F204040DJ	NTC (10KOhms @25°C)	170	0.5~0.8°C (0.9~1.4°F)
4-40°C (40-105°F)	Y1S2PN6F204040EJ	Y1R2PN6F204040EJ	NTC (10KOhms @25°C)	230	0.5~0.8°C (0.9~1.4°F)
4-40°C (40-105°F)	Y1S2PN6F204040FJ	Y1R2PN6F204040FJ	NTC (10KOhms @25°C)	300	0.5~0.8°C (0.9~1.4°F)
4-40°C (40-105°F)	Y1S2PN6F204040GJ	Y1R2PN6F204040GJ	NTC (10KOhms @25°C)	450	0.5~0.8°C (0.9~1.4°F)
30-90°C (85-195°F)	Y1S2PN6F230090BJ	Y1R2PN6F230090BJ	NTC (10KOhms @25°C)	90	0.5~0.8°C (0.9~1.4°F)
30-90°C (85-195°F)	Y1S2PN6F230090CJ	Y1R2PN6F230090CJ	NTC (10KOhms @25°C)	110	0.5~0.8°C (0.9~1.4°F)
30-90°C (85-195°F)	Y1S2PN6F230090DJ	Y1R2PN6F230090DJ	NTC (10KOhms @25°C)	170	0.5~0.8°C (0.9~1.4°F)
30-90°C (85-195°F)	Y1S2PN6F230090EJ	Y1R2PN6F230090EJ	NTC (10KOhms @25°C)	230	0.5~0.8°C (0.9~1.4°F)
30-90°C (85-195°F)	Y1S2PN6F230090FJ	Y1R2PN6F230090FJ	NTC (10KOhms @25°C)	300	0.5~0.8°C (0.9~1.4°F)
30-90°C (85-195°F)	Y1S2PN6F230090GJ	Y1R2PN6F230090GJ	NTC (10KOhms @25°C)	450	0.5~0.8°C (0.9~1.4°F)
30-90°C (85-195°F)	Y1S2PN6F230090HJ	Y1R2PN6F230090HJ	NTC (10KOhms @25°C)	600	0.5~0.8°C (0.9~1.4°F)
30-90°C (85-195°F)	Y1S2PN6F230090JJ	Y1R2PN6F230090JJ	NTC (10KOhms @25°C)	800	0.5~0.8°C (0.9~1.4°F)
30-110°C (85-230°F)	Y1S2PN6F230110BJ	Y1R2PN6F230110BJ	NTC (10KOhms @25°C)	90	0.5~0.8°C (0.9~1.4°F)
30-110°C (85-230°F)	Y1S2PN6F230110CJ	Y1R2PN6F230110CJ	NTC (10KOhms @25°C)	110	0.5~0.8°C (0.9~1.4°F)
30-110°C (85-230°F)	Y1S2PN6F230110DJ	Y1R2PN6F230110DJ	NTC (10KOhms @25°C)	170	0.5~0.8°C (0.9~1.4°F)
30-110°C (85-230°F)	Y1S2PN6F230110EJ	Y1R2PN6F230110EJ	NTC (10KOhms @25°C)	230	0.5~0.8°C (0.9~1.4°F)
30-110°C (85-230°F)	Y1S2PN6F230110FJ	Y1R2PN6F230110FJ	NTC (10KOhms @25°C)	300	0.5~0.8°C (0.9~1.4°F)
30-110°C (85-230°F)	Y1S2PN6F230110GJ	Y1R2PN6F230110GJ	NTC (10KOhms @25°C)	450	0.5~0.8°C (0.9~1.4°F)
30-110°C (85-230°F)	Y1S2PN6F230110HJ	Y1R2PN6F230110HJ	NTC (10KOhms @25°C)	600	0.5~0.8°C (0.9~1.4°F)
30-110°C (85-230°F)	Y1S2PN6F230110JJ	Y1R2PN6F230110JJ	NTC (10KOhms @25°C)	800	0.5~0.8°C (0.9~1.4°F)
30-110°C (85-230°F)	Y1S2PN6F230110KJ	Y1R2PN6F230110KJ	NTC (10KOhms @25°C)	1000	0.5~0.8°C (0.9~1.4°F)
50-200°C (120-390°F)	Y1S2PP6F250200EJ	Y1R2PP6F250200EJ	Pt100	230	0.5~0.8°C (0.9~1.4°F)
50-200°C (120-390°F)	Y1S2PP6F250200FJ	Y1R2PP6F250200FJ	Pt100	300	0.5~0.8°C (0.9~1.4°F)
50-200°C (120-390°F)	Y1S2PP6F250200GJ	Y1R2PP6F250200GJ	Pt100	450	0.5~0.8°C (0.9~1.4°F)
50-200°C (120-390°F)	Y1S2PP6F250200HJ	Y1R2PP6F250200HJ	Pt100	600	0.5~0.8°C (0.9~1.4°F)
50-200°C (120-390°F)	Y1S2PP6F250200JJ	Y1R2PP6F250200JJ	Pt100	800	0.5~0.8°C (0.9~1.4°F)
50-300°C (120-570°F)	Y1S2PP6F250300FJ	Y1R2PP6F250300FJ	Pt100	300	0.5~0.8°C (0.9~1.4°F)
50-300°C (120-570°F)	Y1S2PP6F250300GJ	Y1R2PP6F250300GJ	Pt100	450	0.5~0.8°C (0.9~1.4°F)
50-300°C (120-570°F)	Y1S2PP6F250300HJ	Y1R2PP6F250300HJ	Pt100	600	0.5~0.8°C (0.9~1.4°F)
100-400°C (210-750°F)	Y1S2PP6F2A0400FJ	Y1R2PP6F2A0400FJ	Pt100	300	0.5~0.8°C (0.9~1.4°F)
100-400°C (210-750°F)	Y1S2PP6F2A0400GJ	Y1R2PP6F2A0400GJ	Pt100	450	0.5~0.8°C (0.9~1.4°F)
100-400°C (210-750°F)	Y1S2PP6F2A0400HJ	Y1R2PP6F2A0400HJ	Pt100	600	0.5~0.8°C (0.9~1.4°F)
100-500°C (210-930°F)	Y1S2PP6F2A0500FJ	Y1R2PP6F2A0500FJ	Pt100	300	0.5~0.8°C (0.9~1.4°F)
100-500°C (210-930°F)	Y1S2PP6F2A0500GJ	Y1R2PP6F2A0500GJ	Pt100	450	0.5~0.8°C (0.9~1.4°F)
100-500°C (210-930°F)	Y1S2PP6F2A0500HJ	Y1R2PP6F2A0500HJ	Pt100	600	0.5~0.8°C (0.9~1.4°F)

\*F printing: replace last character (J) by K.

\* Above 200°C we recommend to use a rod cooler reference 66RF07015 or 66RF0701F12 between the rod and the enclosure (see accessories).  
Caution: This cooler reduces the usable rod length by 70mm.

Because of permanent improvement of our products, drawings, descriptions, features used on these data sheets are for guidance only and can be modified without prior advice

# Manual reset electronic rod limiter



## Knob printings

°C Printing			
-35+35°C	4-40°C	30-90°C	30-110°C
50-200°C	50-300°C	100-400°C	100-500°C
°F Printing			
-30+95°F	40-105°F	85-195°F	85-230°F
120-390°F	120-570°F	210-750°F	210-930°F

Because of permanent improvement of our products, drawings, descriptions, features used on these data sheets are for guidance only and can be modified without prior advice

# Manual reset electronic adjustable limiter, pipe mounting



Enclosure	Type	Operation	Contact	Measurement	Ranges °C	Models
IP65, IK10	Limiter	Electronic	SPNO or SPNC	Pipe		<b>Y112L</b> <b>Y102L</b>
Material						
Aluminum						

<p>Y112L: External adjustment and external reset (With pilot light)</p>		<p>Y102L: Internal adjustment and reset (Without pilot light)</p>	

## Applications:

Pipes surface **temperature alarm or high limit** in usual industrial applications and environments. (No suitable for hazardous areas)

Internal adjustment is convenient for products that must not be frequently adjusted.

**Housing:** Aluminum, IP65, IK10. Grey RAL7032 epoxy painting. Stainless steel captive cover screws. Captive aluminum lid.

**Operation:** Microprocessor manual reset electronic limiter, with adjustable set point.

**Adjustment ranges:** 4-40°C (40-105°F); 30-90°C (85-195°F).

**Set point adjustment:** By °C printed knob. All types have an adjustable rotation limit system located inside the knob that allows reducing the set point adjustment span. Types with external adjustment have a transparent window. This device allows seeing the pilot light and the knob position. °F values are available as an option.

**Reset:** by push button switch beside the knob.

**Sensing element:** NTC sensor inside aluminum bracket in contact with the pipe surface. The bracket design provides optimized thermal contact with 34mm (1", DN25), 60mm (2", DN50) and 90mm (3", DN80) outside diameter tubes. For intermediate sizes, we recommend the use of thermal grease.

**Cable input and output:** Two M20 cable glands, Black PA66. Internal electrical connection on screw terminals. 2 phases power supply (Line+ Neutral, 220~250V, 50Hz~60Hz) are mandatory.

**Earthing:** Internal and external screw terminal.

**Pilot light:** Allows to visualize thermostat contact output position. Standard for all models with transparent window. Non Standard and on special request only for models with plain aluminum cover.

**Mounting:** The thermostat housing can be fixed on the pipe by worm drive hose clamps (DIN3017), nylon cable ties (Tie wraps upon EN50146, for applications at permanent temperature lower than 85°C), or specific stainless steel punched band (see accessories at the end of this catalog).

**Identification:** Metallic identification label, riveted.

**Contact:** SPST. 16A (2.6), 250VAC. Open or close on temperature rise. **The version with contact closing on temperature rise is used to switch on an alarm. The version with contact opening on temperature rise is used to switch-off heating.**

**Electrical life:** >100,000 cycles.

**Minimum storage temperature:** -35°C (-30°F)

**Maximum ambient temperature:** 60°C (140°F)

For more technical information ask ZPE2N6 thermostat technical data sheet.

Because of permanent improvement of our products, drawings, descriptions, features used on these data sheets are for guidance only and can be modified without prior advice

# Manual reset electronic adjustable limiter, pipe mounting



## Main references

Temperature adjustment ranges °C (°F)	Open on temperature rise contact		Close on temperature rise contact		Max. temperature on tube °C (°F)
	Reference with external adjustment	Reference with internal adjustment	Reference with external adjustment	Reference with internal adjustment	
4-40°C (40-105°F)	Y112PN6F204040AJ	Y102PN6F204040AJ	Y112PN6G204040AJ	Y102PN6G204040AJ	100°C (212°F)
30-90°C (85-195°F)	Y112PN6F230090AJ	Y102PN6F230090AJ	Y112PN6G230090AJ	Y102PN6G230090AJ	100°C (212°F)

°F printing: replace last character (J) by K.

## Knob printings

°C Printing		°F Printing	
4-40°C	30-90°C	40-105°F	85-195°F

Because of permanent improvement of our products, drawings, descriptions, features used on these data sheets are for guidance only and can be modified without prior advice



# Probe sensor adjustable manual reset electronic limiters



Enclosure	Type	Operation	Contact	Measurement	Ranges °C	Models
IP66, IK10	Limiters	Electronic	SPNO or SPNC	Probe	+110°C +4°C	YF43NC YF45NC
Material PA66 & PC						

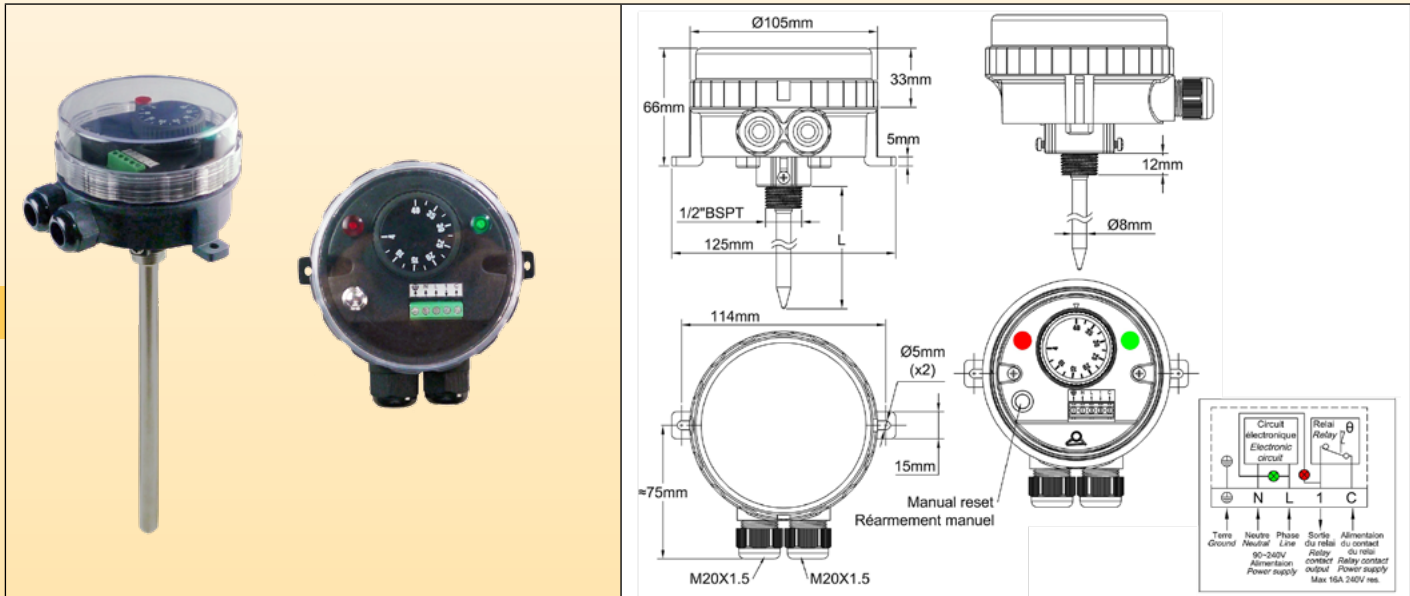

## Applications:

- Equipment requesting a very strong resistance to water ingress. The transparent cover allows to visualize the set point and the 2 pilot lights.

These **electronic** rod thermostats are installed inside pockets as immersion thermostats in pipelines and containers, and for monitoring temperature in air ducts.

- Manual reset allows the use as **high temperature alarm**

**Housing:** Protection class IP 66 upon EN 60529 (waterproof spray water under high pressure and sea splashes, totally dust tight). Body in black PA66, fiber glass reinforced. The transparent polycarbonate cover can be unscrewed by hand, but it is also possible to use a hook spanner.

**Set point adjustment:** By °C printed knob. All types have an adjustable rotation limit system located inside the knob that allows reducing the set point adjustment span. °F printed knobs available as an option

**Operation:** Microprocessor electronic thermostat.

**Set point adjustment ranges:** -4-40°C (40-105°F); 30-90°C (85-195°F); 30-110°C (85-230°F).

**Manual reset button:** located beside the knob

**Sensing element:** Dia. 5mm NTC sensor (10KOhms @25°C), inside nickel plated brass pocket. Thread ½" BSPT. Tube outside diameter 8mm. Maximum temperature on the probe: 120°C (250°F). Located at the bottom of the housing, 2 screws are used to secure standard pockets. (See the compatible brass pockets range in the accessories section).

**Pilot lights:** One pilot light visualizes the thermostat contact output position. The other visualizes the power supply input. Phase and line 230V power supply is mandatory for these pilot lights.

**Cable input and output:** Two M20 cable glands, built-in black PA66.

**Electrical connections:** Inside, on screw terminal connection block. It is possible to connect 2 wires 1.5mm<sup>2</sup> on each terminal.

**Earthing:** Internal screw terminal.

**Mounting:** By the pocket thread or by 2 legs with holes for screws dia. 4 to 5mm, 114mm distance.

**Identification:** Identification label on backside

**Contact:** SPST. 16A (2.6), 250VAC. Open or close on temperature rise.

Model with contact closing on temperature rise is used to switch on an alarm. Version with contact opening on temperature rise is used to switch off heating.

**Electrical life:** >100.000 cycles.

**Minimum storage temperature:** -35°C (-30°F)

**Maximum ambient temperature:** 60°C (140°F)

For more technical information see 2PE2N6 thermostat technical data sheet.

Because of permanent improvement of our products, drawings, descriptions, features used on these data sheets are for guidance only and can be modified without prior advice



# Probe sensor adjustable manual reset electronic limiters



Because of permanent improvement of our products, drawings, descriptions, features used on these data sheets are for guidance only and can be modified without prior advice

## Main references

Temperature adjustment ranges °C (°F)	References with SPNC contact, open on temperature rise	References with SPNO contact, close on temperature rise	Pocket length (L, mm)	Temperature sensing length (mm)
4-40°C (40-105°F)	YF43NC04040118UJ	YF44NC04040118UJ	110	50
4-40°C (40-105°F)	YF43NC04040178UJ	YF44NC04040178UJ	170	50
4-40°C (40-105°F)	YF43NC04040238UJ	YF44NC04040238UJ	230	50
4-40°C (40-105°F)	YF43NC04040308UJ	YF44NC04040308UJ	300	50
4-40°C (40-105°F)	YF43NC04040458UJ	YF44NC04040458UJ	450	50
4-40°C (40-105°F)	YF43NC04040608UJ	YF44NC04040608UJ	600	50
30-90°C (85-195°F)	YF43NC30090118UJ	YF44NC30090118UJ	110	50
30-90°C (85-195°F)	YF43NC30090178UJ	YF44NC30090178UJ	170	50
30-90°C (85-195°F)	YF43NC30090238UJ	YF44NC30090238UJ	230	50
30-90°C (85-195°F)	YF43NC30090308UJ	YF44NC30090308UJ	300	50
30-90°C (85-195°F)	YF43NC30090458UJ	YF44NC30090458UJ	450	50
30-90°C (85-195°F)	YF43NC30090608UJ	YF44NC30090608UJ	600	50
30-110°C (85-230°F)	YF43NC30110118UJ	YF44NC30110118UJ	110	50
30-110°C (85-230°F)	YF43NC30110178UJ	YF44NC30110178UJ	170	50
30-110°C (85-230°F)	YF43NC30110238UJ	YF44NC30110238UJ	230	50
30-110°C (85-230°F)	YF43NC30110308UJ	YF44NC30110308UJ	300	50
30-110°C (85-230°F)	YF43NC30110458UJ	YF44NC30110458UJ	450	50
30-110°C (85-230°F)	YF43NC30110608UJ	YF44NC30110608UJ	600	50

\*F printing: replace last character (J) by K.

## Knob printings

°C Printing		
4-40°C	30-90°C	30-110°C
°F Printing		
40-105°F	85-195°F	85-230°F

**Manual reset electronic rod adjustable limiter, with high corrosion resistance IP66 housing, specifically designed for surface treatment baths, and highly basic or acid corrosive liquids or environments.**

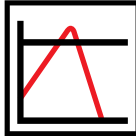
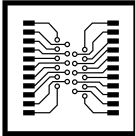
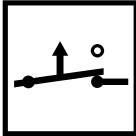
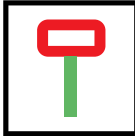

Environment	Type	Operation	Contact	Measurement	Ranges °C	Models
IP66, IK10	Manual reset	Electronic	SPNC	Rod	+110°C +4°C	<b>YF53</b>
						

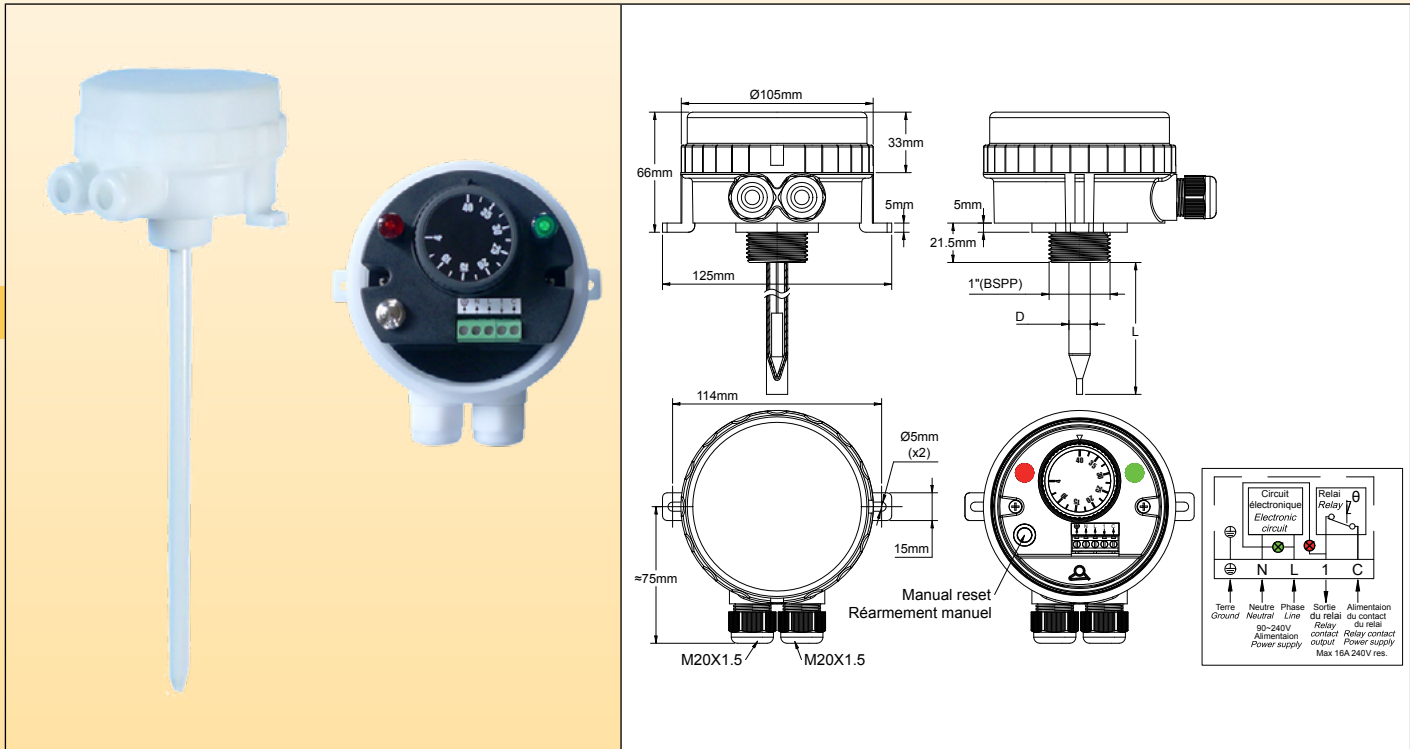

## Main applications

**Adjustable manual reset temperature limiter** for surface treatment or corrosive liquid baths, sea water environment, livestock premises.

**Housing:** Protection class IP 66 upon EN 60529 (waterproof spray water under high pressure and sea splashes, totally dust tight), dia. 105mm, height 66mm (excluding accessories and cable glands), made of plastic. Includes an adjustable thermostat that can be set after unscrewing the cover. To eliminate the enclosure risk of corrosion, there is no metallic part in contact with the external environment. Cover gasket and cable gland stuffing sets gaskets are made in EPDM. Rod seal is made of fluorocarbon elastomer FKM (Viton). The cover can be unscrewed by hand, but it is also possible to use a hook spanner.

**Electrical connections:** Cable input/output by two M20 cable glands. Electrical connection on screw terminals

**Temperature Adjustment:** Inside, with °C printed knob. (°F printed knobs available as an option). Knobs have an invisible device to reduce the temperature range span.

**Manual reset:** Button located beside the temperature adjustment knob

**Sensing element:** NTC thermistor and microprocessor electronic circuit.

**Adjustment ranges:** 4-40°C (32- 104°F); 30-90°C (85-195°F); 30-110°C (90-230°F)

**Rod dimensions:** Outside diameter (D) before optional sleeving is 10mm. Length (L): 450mm, 600mm (300mm, 800mm and 1000mm on request )

**Rod material and sleeving:**

- SUS 316L without sleeving
- Titanium
- SUS 316L with shrunk PTFE sleeve, thickness 0.4 to 0.6mm

**Mounting:**

- By the 1" BSPT thread (Mounting through wall is watertight when used with the 1" nut and seal. See accessories)
- By a rotatable plastic bracket, enabling mounting on tank edge (See accessories)
- By the 2 legs on the side (2 holes dia 5mm center distance 114mm)

**Electrical contact:**

- SPNC, Open on temperature rise contact (C-1) 16A (2.6) 250VAC

**Manual reset electronic rod adjustable limiter, with high corrosion resistance IP66 housing, specifically designed for surface treatment baths, and highly basic or acid corrosive liquids or environments.**



Because of permanent improvement of our products, drawings, descriptions, features used on these data sheets are for guidance only and can be modified without prior advice

- Electrical life >100.000 cycles.

Power supply and power output pilot lights (Neutral is mandatory).

**Cover and housing material options:**

- Black PA66, glass filled body, and polycarbonate (PC) transparent cover, suitable for most applications in medium low to medium corrosive liquids, up to 90°C. Allows to view constantly input and output power supply and thermostat set point. Excellent mechanical strength of the housing (IK10). Very good UV resistance.

- Orange PP (polypropylene) body, with transparent polycarbonate (PC) cover: Very good resistance to strong bases, good resistance to acids. For use on liquids up to 90°C. Allows viewing constantly input and output power supply and thermostat set point. Reduced mechanical strength (IK8).

- Orange PP (polypropylene) body, with opaque orange PP (polypropylene) cover: Very good resistance to strong bases, good resistance to acids. For use in liquids up to 90°C. Reduced mechanical strength (IK8).

- White PVDF body with opaque white PVDF cover: For use in liquid baths at temperatures above 90°C and up to 110°C or strong oxidizing chemicals such as chrome electrolyte or nitric acid solution (HNO3). Reduced mechanical strength (IK8).

**Rod protection options (see also table below)**

- Stainless steel 316L-Ti without coating

- Stainless steel 316L, with FEP chemically deposited coating, thickness 0.2 to 0.4mm

- Stainless steel 316L, with PFA chemically deposited coating, thickness 0.2 to 0.4mm

- Stainless steel 316L, with PTFE chemically deposited coating, thickness 0.05 to 0.1mm

- Stainless steel 316L, with ETFE chemically deposited coating, thickness 0.2 to 0.4mm

**Main references with SS 316L rod, coated with shrinked PTFE**

Temperature ranges °C (°F)	Rod length (L, mm)	Black PA66 housing, crystal clear PC cover	Orange PP housing, crystal clear PC cover	Orange PP housing, orange opaque PP cover	White PVDF housing, white opaque PVDF cover	Differential* °C (°F)	Max temperature on probe °C (°F)
4-40°C (32-104°F)	450	YF53NCS04040451P	YF53PCS04040451P	YF53PPS04040451P	YF53VVS04040451P	0.8±0.2°C (1.5±0.4°F)	120°C (250°F)
30-90°C (85-195°F)	450	YF53NCS30090451P	YF53PCS30090451P	YF53PPS30090451P	YF53VVS30090451P	1±0.3°C (1.8±0.5°F)	120°C (250°F)
30-110°C (90-230°F)	450	YF53NCS30110451P	YF53PCS30110451P	YF53PPS30110451P	YF53VVS30110451P	1±0.3°C (1.8±0.5°F)	120°C (250°F)
4-40°C (32-104°F)	600	YF53NCS04040601P	YF53PCS04040601P	YF53PPS04040601P	YF53VVS04040601P	0.8±0.2°C (1.5±0.4°F)	120°C (250°F)
30-90°C (85-195°F)	600	YF53NCS30090601P	YF53PCS30090601P	YF53PPS30090601P	YF53VVS30090601P	1±0.3°C (1.8±0.5°F)	120°C (250°F)
30-110°C (90-230°F)	600	YF53NCS30110601P	YF53PCS30110601P	YF53PPS30110601P	YF53VVS30110601P	1±0.3°C (1.8±0.5°F)	120°C (250°F)

\* Differentials measured in laboratory conditions, in agitated liquid baths, with temperature change rates below 0.5°C/min.

**Reference modifications vs options**

Rod length		
300mm	800mm	1000mm
xxxxxxxxxxx30xx	xxxxxxxxxxx80xx	xxxxxxxxxxxA0xx

Rod protection coating						
316L without coating	316L-Ti without coating	Titanium	316L+ FEP 0.2 ~ 0.4mm*	316L+ PFA 0.2 ~ 0.4mm*	316L+ PTFE 0.05 ~ 0.1mm*	316L+ ETFE 0.2 ~ 0.4mm*
xxxxxxxxxxxU	xxxxxxxxxxxV	xxxxxxxxxxxW	xxxxxxxxxxxQ	xxxxxxxxxxxR	xxxxxxxxxxxS	xxxxxxxxxxxT

\* MOQ 100 pieces.

Versions with °F printed knobs: replace S by T in the reference (7<sup>th</sup> character)

**Manual reset electronic rod adjustable limiter, with high corrosion resistance IP66 housing, specifically designed for surface treatment baths, and highly basic or acid corrosive liquids or environments.**

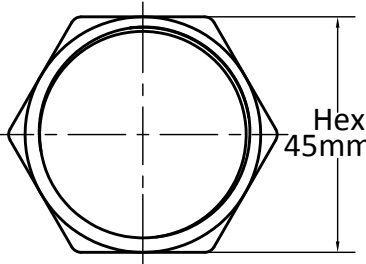
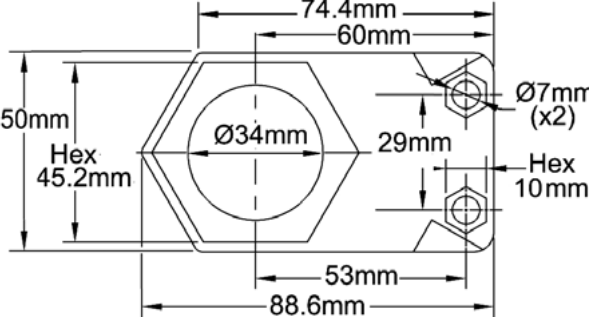
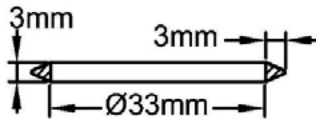

### Accessories

1" BSPP Nut, 5mm thickness	Bracket for tank side mounting, thickness 10mm (Assembly made with 1" nut)	1" gasket for through wall waterproof mounting with 1" nut
		
Reference in PA66:66YFHN1N	Reference in PA66:66YFMB1N	Reference in FKM (Viton):66YGA1F
Reference in PP: 66YFHN1P	Reference in PP: 66YFMB1P	
Reference in PVDF: 66YFHN1V	Reference in PVDF: 66YFMB1V	

Because of permanent improvement of our products, drawings, descriptions, features used on these data sheets are for guidance only and can be modified without prior advice



Because of permanent improvement of our products, drawings, descriptions, features used on these data sheets are for guidance only and can be modified without prior advice

# Accessories



Because of permanent improvement of our products, drawings, descriptions, features used on these data sheets are for guidance only and can be modified without prior advice













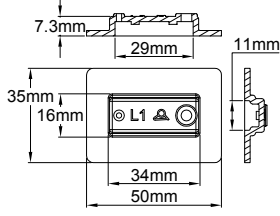

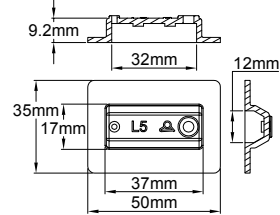

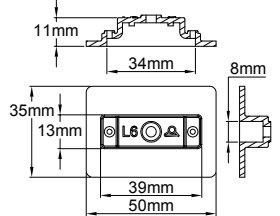
# Silicone boots for mounting **fixed setting limiters or thermostats** on flexible silicone heaters. Assembly by bonding or vulcanization.

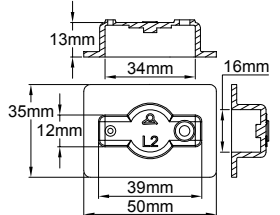

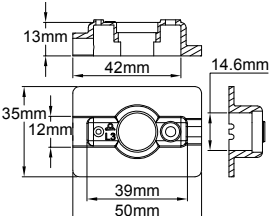
Because of permanent improvement of our products, drawings, descriptions, features used on these data sheets are for guidance only and can be modified without prior advice

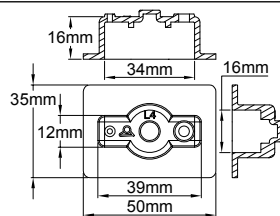
Type
<b>9BFL</b>

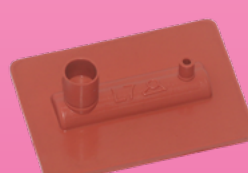
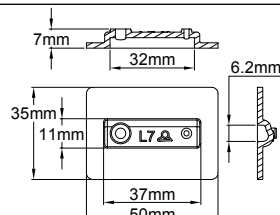
These boots comprise a degassing orifice and a “funnel” orifice for filling the silicone resin, which are cut after curing.

Type	Dimensions	Compatible devices	Features	Part number
		 UJW	<b>Minimum band width: 35mm</b> <b>Connection: internal</b> <b>Silicone resin filling: yes</b>	9BFL1
		 4A	<b>Minimum band width: 35mm</b> <b>Connection: internal</b> <b>Silicone resin filling: yes</b>	9BFL5
		 4T	<b>Minimum band width: 35mm</b> <b>Connection: internal</b> <b>Silicone resin filling: no</b>	9BFL6
		 4903	<b>Minimum band width: 35mm</b> <b>Connection: internal</b> <b>Silicone resin filling: yes</b>	9BFL2
		 4903	<b>Minimum band width: 35mm</b> <b>Connection: external by 2 wires</b> <b>Silicone resin filling: yes</b>	9BFL3
		 4505	<b>Minimum band width: 35mm</b> <b>Connection: internal</b> <b>Silicone resin filling: partial</b>	9BFL4
		 5MA3	<b>Minimum band width: 35mm</b> <b>Connection: internal</b> <b>Silicone resin filling: yes</b>	9BFL7









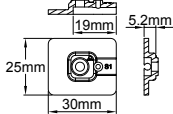

# Silicone boots for mounting of **temperature sensors and thermostats bulbs** on flexible silicone heaters surface. Assembly by bonding or vulcanization.

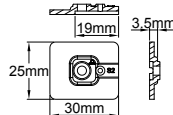
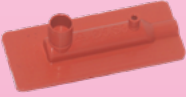
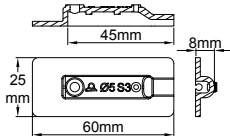

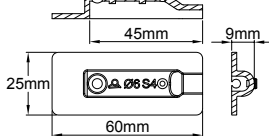
Type

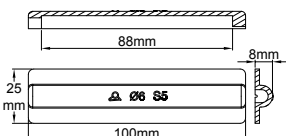
**9BFS**

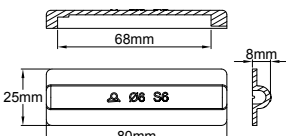
Some of these boots comprise a degassing orifice and a “funnel” orifice for filling the silicone resin, which are cut after curing.

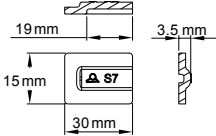
Type	Dimensions	Compatible devices	Features	Part number
		Flat RTD	<b>Minimum band width:</b> 25mm <b>Connection:</b> external sensor cable <b>Silicone resin filling:</b> yes	9BFS1
		Naked welding thermocouple or glass bead thermistor	<b>Minimum band width:</b> 25mm <b>Connection:</b> external sensor cable <b>Silicone resin filling:</b> yes	9BFS2
		Temperature sensor dia. 5mm, 30mm maximum length	<b>Minimum band width:</b> 25mm <b>Connection:</b> external sensor cable <b>Silicone resin filling:</b> yes	9BFS3
		Temperature sensor dia. 6mm, 30mm maximum length	<b>Minimum band width:</b> 25mm <b>Connection:</b> external sensor cable <b>Silicone resin filling:</b> yes	9BFS4
		Temperature sensor dia. 6mm or thermostat bulb dia. 6mm, maximum length 88mm	<b>Minimum band width:</b> 25mm <b>Connection:</b> external sensor cable or capillary <b>Silicone resin filling:</b> possible	9BFS5
		Temperature sensor dia. 6mm or thermostat bulb dia. 6mm, maximum length 68mm	<b>Minimum band width:</b> 25mm <b>Connection:</b> external sensor cable or capillary <b>Silicone resin filling:</b> possible	9BFS6
		Naked welding thermocouple or glass bead thermistor	<b>Minimum band width:</b> 15mm <b>Connection:</b> external sensor cable or capillary <b>Silicone resin filling:</b> possible	9BFS7

Because of permanent improvement of our products, drawings, descriptions, features used on these data sheets are for guidance only and can be modified without prior advice

# Silicone enclosures for mounting of adjustable thermostats on flexible silicone heaters surface. Assembly by bonding or vulcanization.







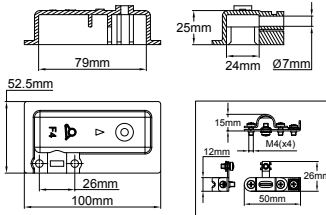

Because of permanent improvement of our products, drawings, descriptions, features used on these data sheets are for guidance only and can be modified without prior advice

Type

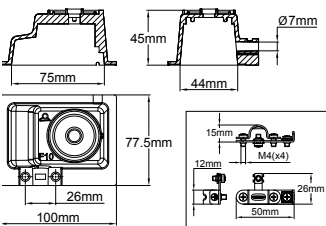
**9BFF**

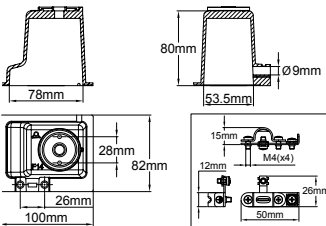
These enclosures include a stainless-steel removable locking device for the power cable and an internal and external grounding terminal. Some models also include a thick insulating silicone foam pad to thermally insulate the thermostat body from the temperature of the heater. The models for bulb and capillary thermostat have a lateral outlet for the capillary. The flexibility of the silicone makes it possible to use cables with a diameter slightly greater (up to 15%) than that of the passage opening.

Type	Dimensions	Compatible devices	Features	Part number
		 IB	<b>Minimum band width:</b> 100mm <b>Connection:</b> external cable <b>Silicone resin filling:</b> no	9BFF4
		 8G	<b>Minimum band width:</b> 100mm <b>Connection:</b> external cable and external bulb and capillary <b>Silicone resin filling:</b> no	9BFF10
		 8C	<b>Minimum band width:</b> 100mm <b>Connection:</b> external cable and external bulb and capillary <b>Silicone resin filling:</b> no	9BFF14

## Indicative table of cable and wire diameters

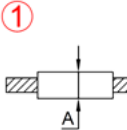
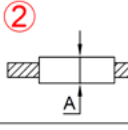
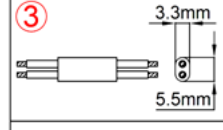
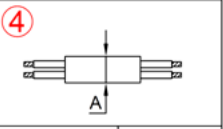
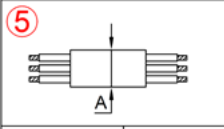
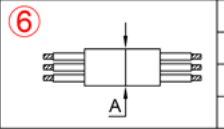
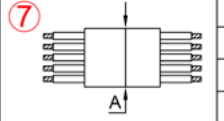
	AWG22	A=Ø1.4±0.1		0.5 mm <sup>2</sup>	A=Ø1.5±0.1	
	AWG20	A=Ø1.6±0.1		0.75 mm <sup>2</sup>	A=Ø1.8±0.1	
	AWG18	A=Ø1.9±0.1		1 mm <sup>2</sup>	A=Ø1.9±0.1	
	AWG16	A=Ø2.2±0.1		1.5 mm <sup>2</sup>	A=Ø2.2±0.1	
	AWG15	A=Ø2.3±0.1		2 X 0.75 mm <sup>2</sup>		
	2 X 0.75 mm <sup>2</sup>	A=Ø6.5±0.1			3 X 1.5 mm <sup>2</sup>	A=Ø9.1±0.2
	2 X 1 mm <sup>2</sup>	A=Ø6.8±0.1			3 X 1 mm <sup>2</sup>	A=Ø7.2±0.1
					3 X AWG18	A=Ø7.8±0.2
					3 X AWG16	A=Ø8.4±0.2
					5 X 1.5 mm <sup>2</sup>	A=Ø11.1±0.2
					5 X 1 mm <sup>2</sup>	A=Ø9.0±0.2
					5 X AWG18	A=Ø9.3±0.2
					5 X AWG16	A=Ø10.1±0.2



- 1: Round wires FEP insulation, 300V, dimensions USA;
- 2: Round wires FEP insulation, 300V, European dimensions;
- 3: Flat cable PVC insulation, 300V, European dimensions;
- 4: Round cables 2 conductors PVC insulation, 300V, European dimensions;
- 5: Round cables 3 conductors PVC insulation, 300V, European dimensions;
- 6: Round cables 3 conductors rubber insulation 300V, European and USA dimensions.
- 7: Round cables 5 conductors rubber insulation 300V, European and USA dimensions.

# Silicone boots for **red cable outputs** on flexible silicone heaters surface. Assembly by bonding or vulcanization.

Type

**9BFH**

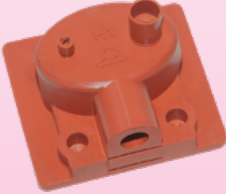
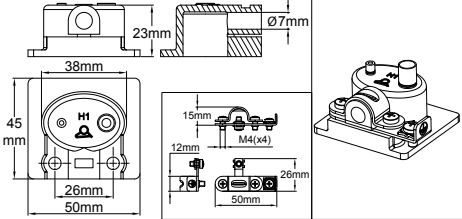
These enclosures include a stainless-steel removable locking device for the power cable and an internal and external grounding terminal. The flexibility of the silicone makes it possible to use cables with a diameter slightly greater (up to 15%) than that of the passage opening.

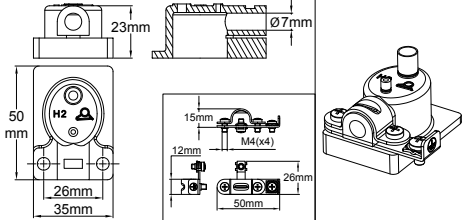
Type	Dimensions	Compatible devices	Features	Part number
		Band heaters with 50mm minimum width	<b>Minimum band width:</b> 50mm <b>Connection:</b> external cable <b>Silicone resin filling:</b> yes	9BFH1
		Band heaters with 35mm minimum width	<b>Minimum band width:</b> 35mm <b>Connection:</b> external cable <b>Silicone resin filling:</b> no	9BFH2

## Indicative table of cable and wire diameters

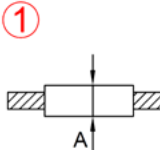
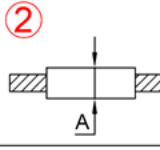
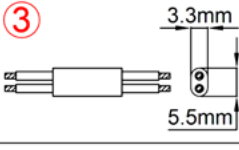
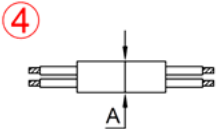
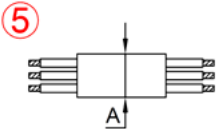
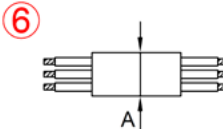
	AWG22	A=Ø1.4±0.1		0.5 mm <sup>2</sup>	A=Ø1.5±0.1	
	AWG20	A=Ø1.6±0.1		0.75 mm <sup>2</sup>	A=Ø1.8±0.1	
	AWG18	A=Ø1.9±0.1		1 mm <sup>2</sup>	A=Ø1.9±0.1	
	AWG16	A=Ø2.2±0.1		1.5 mm <sup>2</sup>	A=Ø2.2±0.1	
	AWG15	A=Ø2.3±0.1		2 X 0.75 mm <sup>2</sup>		
	2 X 0.75 mm <sup>2</sup>	A=Ø6.5±0.1		<p>6: 3 X 1.5 mm<sup>2</sup> A=Ø9.1±0.2                      3 X 1 mm<sup>2</sup> A=Ø7.4±0.2                      3 X AWG18 A=Ø7.8±0.2                      3 X AWG16 A=Ø8.4±0.2</p> <p>7: 5 X 1.5 mm<sup>2</sup> A=Ø11.1±0.2                      5 X 1 mm<sup>2</sup> A=Ø9.0±0.2                      5 X AWG18 A=Ø9.3±0.2                      5 X AWG16 A=Ø10.1±0.2</p>		
	2 X 1 mm <sup>2</sup>	A=Ø6.8±0.1				
	3 X 1 mm <sup>2</sup>	A=Ø7.2±0.1				
	3 X 1.5 mm <sup>2</sup>	A=Ø8.4±0.1				

- 1: Round wires FEP insulation, 300V, dimensions USA;
- 2: Round wires FEP insulation, 300V, European dimensions;
- 3: Flat cable PVC insulation, 300V, European dimensions;
- 4: Round cables 2 conductors PVC insulation, 300V, European dimensions;
- 5: Round cables 3 conductors PVC insulation, 300V, European dimensions;
- 6: Round cables 3 conductors rubber insulation 300V, European and USA dimensions.
- 7: Round cables 5 conductors rubber insulation 300V, European and USA dimensions.

Because of permanent improvement of our products, drawings, descriptions, features used on these data sheets are for guidance only and can be modified without prior advice





# Silicone boots for **cable outputs with temperature limiters** on flexible silicone heaters surface. Assembly by bonding or vulcanization.

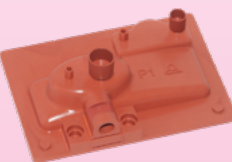
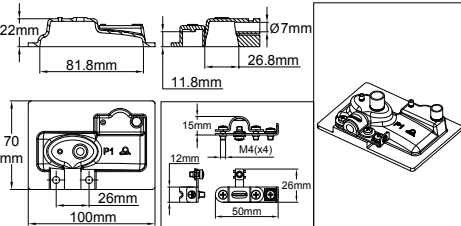

Because of permanent improvement of our products, drawings, descriptions, features used on these data sheets are for guidance only and can be modified without prior advice

Type
9BFP

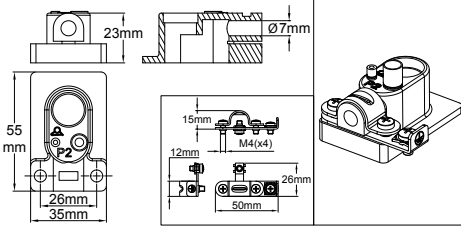
These enclosures include a stainless-steel removable locking device for the power cable and an internal and external grounding terminal. The flexibility of the silicone makes it possible to use cables with a diameter slightly greater (up to 15%) than that of the passage opening. They also comprise a degassing orifice and a "funnel" orifice for filling the silicone resin, which are cut after curing.

Type	Dimensions	Compatible devices	Features	Part number
		 4903	<p><b>Minimum band width:</b> 100mm  <b>Connection:</b> external cable  <b>Silicone resin filling:</b> yes</p>	9BFP1
		 4903	<p><b>Minimum band width:</b> 35mm  <b>Connection:</b> external cable  <b>Silicone resin filling:</b> yes</p>	9BFP2

## Indicative table of cable and wire diameters

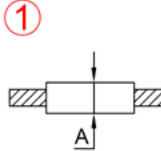
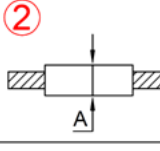
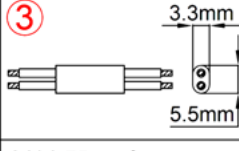
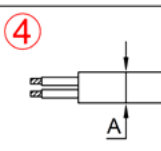
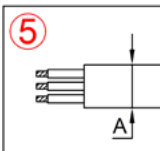
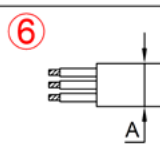
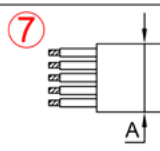
	<table border="1" style="width: 100%;"> <tr><td>AWG22</td><td>A=Ø1.4±0.1</td></tr> <tr><td>AWG20</td><td>A=Ø1.6±0.1</td></tr> <tr><td>AWG18</td><td>A=Ø1.9±0.1</td></tr> <tr><td>AWG16</td><td>A=Ø2.2±0.1</td></tr> <tr><td>AWG15</td><td>A=Ø2.3±0.1</td></tr> </table>	AWG22	A=Ø1.4±0.1	AWG20	A=Ø1.6±0.1	AWG18	A=Ø1.9±0.1	AWG16	A=Ø2.2±0.1	AWG15	A=Ø2.3±0.1		<table border="1" style="width: 100%;"> <tr><td>0.5 mm<sup>2</sup></td><td>A=Ø1.5±0.1</td></tr> <tr><td>0.75 mm<sup>2</sup></td><td>A=Ø1.8±0.1</td></tr> <tr><td>1 mm<sup>2</sup></td><td>A=Ø1.9±0.1</td></tr> <tr><td>1.5 mm<sup>2</sup></td><td>A=Ø2.2±0.1</td></tr> </table>	0.5 mm <sup>2</sup>	A=Ø1.5±0.1	0.75 mm <sup>2</sup>	A=Ø1.8±0.1	1 mm <sup>2</sup>	A=Ø1.9±0.1	1.5 mm <sup>2</sup>	A=Ø2.2±0.1		<table border="1" style="width: 100%;"> <tr><td>3.3mm</td></tr> <tr><td>5.5mm</td></tr> <tr><td>2 X 0.75 mm<sup>2</sup></td></tr> </table>	3.3mm	5.5mm	2 X 0.75 mm <sup>2</sup>
AWG22	A=Ø1.4±0.1																									
AWG20	A=Ø1.6±0.1																									
AWG18	A=Ø1.9±0.1																									
AWG16	A=Ø2.2±0.1																									
AWG15	A=Ø2.3±0.1																									
0.5 mm <sup>2</sup>	A=Ø1.5±0.1																									
0.75 mm <sup>2</sup>	A=Ø1.8±0.1																									
1 mm <sup>2</sup>	A=Ø1.9±0.1																									
1.5 mm <sup>2</sup>	A=Ø2.2±0.1																									
3.3mm																										
5.5mm																										
2 X 0.75 mm <sup>2</sup>																										
	<table border="1" style="width: 100%;"> <tr><td>2 X 0.75 mm<sup>2</sup></td><td>A=Ø6.5±0.1</td></tr> <tr><td>2 X 1 mm<sup>2</sup></td><td>A=Ø6.8±0.1</td></tr> </table>	2 X 0.75 mm <sup>2</sup>	A=Ø6.5±0.1	2 X 1 mm <sup>2</sup>	A=Ø6.8±0.1		<table border="1" style="width: 100%;"> <tr><td>3 X 1 mm<sup>2</sup></td><td>A=Ø7.2±0.1</td></tr> <tr><td>3 X 1.5 mm<sup>2</sup></td><td>A=Ø8.4±0.1</td></tr> </table>	3 X 1 mm <sup>2</sup>	A=Ø7.2±0.1	3 X 1.5 mm <sup>2</sup>	A=Ø8.4±0.1		<table border="1" style="width: 100%;"> <tr><td>3 X 1.5 mm<sup>2</sup></td><td>A=Ø9.1±0.2</td></tr> <tr><td>3 X 1 mm<sup>2</sup></td><td>A=Ø7.4±0.2</td></tr> <tr><td>3 X AWG18</td><td>A=Ø7.8±0.2</td></tr> <tr><td>3 X AWG16</td><td>A=Ø8.4±0.2</td></tr> </table>	3 X 1.5 mm <sup>2</sup>	A=Ø9.1±0.2	3 X 1 mm <sup>2</sup>	A=Ø7.4±0.2	3 X AWG18	A=Ø7.8±0.2	3 X AWG16	A=Ø8.4±0.2					
2 X 0.75 mm <sup>2</sup>	A=Ø6.5±0.1																									
2 X 1 mm <sup>2</sup>	A=Ø6.8±0.1																									
3 X 1 mm <sup>2</sup>	A=Ø7.2±0.1																									
3 X 1.5 mm <sup>2</sup>	A=Ø8.4±0.1																									
3 X 1.5 mm <sup>2</sup>	A=Ø9.1±0.2																									
3 X 1 mm <sup>2</sup>	A=Ø7.4±0.2																									
3 X AWG18	A=Ø7.8±0.2																									
3 X AWG16	A=Ø8.4±0.2																									
	<table border="1" style="width: 100%;"> <tr><td>5 X 1.5 mm<sup>2</sup></td><td>A=Ø11.1±0.2</td></tr> <tr><td>5 X 1 mm<sup>2</sup></td><td>A=Ø9.0±0.2</td></tr> <tr><td>5 X AWG18</td><td>A=Ø9.3±0.2</td></tr> <tr><td>5 X AWG16</td><td>A=Ø10.1±0.2</td></tr> </table>	5 X 1.5 mm <sup>2</sup>	A=Ø11.1±0.2	5 X 1 mm <sup>2</sup>	A=Ø9.0±0.2	5 X AWG18	A=Ø9.3±0.2	5 X AWG16	A=Ø10.1±0.2	<p>                     1: Round wires FEP insulation, 300V, dimensions USA;                      2: Round wires FEP insulation, 300V, European dimensions;                      3: Flat cable PVC insulation, 300V, European dimensions;                      4: Round cables 2 conductors PVC insulation, 300V, European dimensions;                      5: Round cables 3 conductors PVC insulation, 300V, European dimensions;                      6: Round cables 3 conductors rubber insulation 300V, European and USA dimensions.                      7: Round cables 5 conductors rubber insulation 300V, European and USA dimensions.                 </p>																
5 X 1.5 mm <sup>2</sup>	A=Ø11.1±0.2																									
5 X 1 mm <sup>2</sup>	A=Ø9.0±0.2																									
5 X AWG18	A=Ø9.3±0.2																									
5 X AWG16	A=Ø10.1±0.2																									







# Silicone boots for cable outputs and temperature sensor on flexible silicone heaters surface. Assembly by bonding or vulcanization.

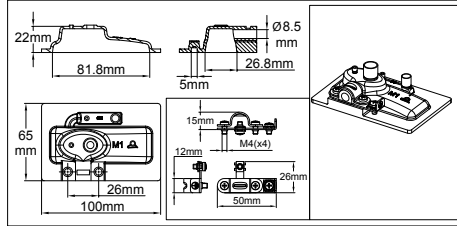

Type

## 9BFM

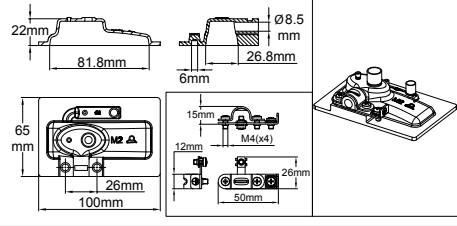
These enclosures include a stainless-steel removable locking device for the power cable and an internal and external grounding terminal. The flexibility of the silicone makes it possible to use cables with a diameter slightly greater (up to 15%) than that of the passage opening. They also comprise a degassing orifice and a «funnel» orifice for filling the silicone resin, which are cut after curing.

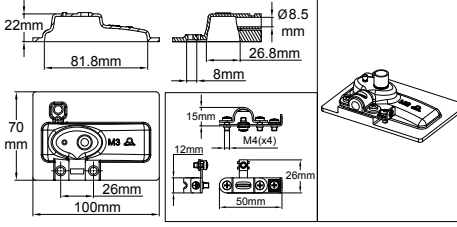
Type	Dimensions	Compatible devices	Features	Part number
		Dia 5mm temperature sensors with 30mm maximum probe length	<b>Minimum band width: 100mm</b> <b>Connection: 5 conductor external cable</b> <b>Silicone resin filling: yes</b>	9BFM1
		Dia. 6mm temperature sensors with 30mm maximum probe length	<b>Minimum band width: 100mm</b> <b>Connection: 5 conductor external cable</b> <b>Silicone resin filling: yes</b>	9BFM2
		Naked welding thermocouples, glass bead NTC, flat chip Pt100	<b>Minimum band width: 100mm</b> <b>Connection: 5 conductor external cable</b> <b>Silicone resin filling: yes</b>	9BFM3

### Indicative table of cable and wire diameters

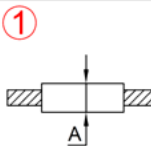
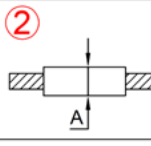
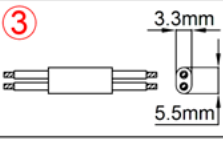
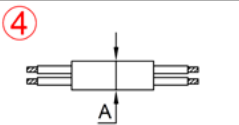
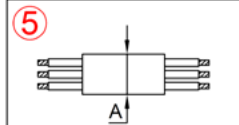
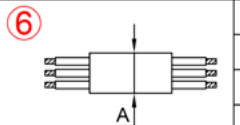
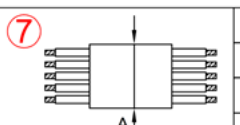
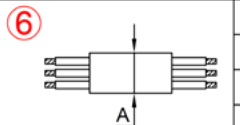
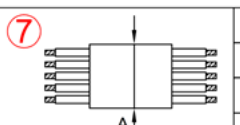
	AWG22	A=Ø1.4±0.1		0.5 mm <sup>2</sup>	A=Ø1.5±0.1	
	AWG20	A=Ø1.6±0.1		0.75 mm <sup>2</sup>	A=Ø1.8±0.1	
	AWG18	A=Ø1.9±0.1		1 mm <sup>2</sup>	A=Ø1.9±0.1	
	AWG16	A=Ø2.2±0.1		1.5 mm <sup>2</sup>	A=Ø2.2±0.1	
	AWG15	A=Ø2.3±0.1		2 X 0.75 mm <sup>2</sup>		
	2 X 0.75 mm <sup>2</sup>	A=Ø6.5±0.1			3 X 1.5 mm <sup>2</sup>	A=Ø9.1±0.2
	2 X 1 mm <sup>2</sup>	A=Ø6.8±0.1			3 X 1 mm <sup>2</sup>	A=Ø7.4±0.2
	3 X 1 mm <sup>2</sup>	A=Ø7.2±0.1			3 X AWG18	A=Ø7.8±0.2
	3 X 1.5 mm <sup>2</sup>	A=Ø8.4±0.1			3 X AWG16	A=Ø8.4±0.2
						5 X 1.5 mm <sup>2</sup>
					5 X 1 mm <sup>2</sup>	A=Ø9.0±0.2
					5 X AWG18	A=Ø9.3±0.2
					5 X AWG16	A=Ø10.1±0.2

- 1: Round wires FEP insulation, 300V, dimensions USA;
- 2: Round wires FEP insulation, 300V, European dimensions;
- 3: Flat cable PVC insulation, 300V, European dimensions;
- 4: Round cables 2 conductors PVC insulation, 300V, European dimensions;
- 5: Round cables 3 conductors PVC insulation, 300V, European dimensions;
- 6: Round cables 3 conductors rubber insulation 300V, European and USA dimensions.
- 7: Round cables 5 conductors rubber insulation 300V, European and USA dimensions.

Because of permanent improvement of our products, drawings, descriptions, features used on these data sheets are for guidance only and can be modified without prior advice



**Silicone boots for cable outputs with temperature limiter and temperature sensor on flexible silicone heaters surface. Assembly by bonding or vulcanization.**







Because of permanent improvement of our products, drawings, descriptions, features used on these data sheets are for guidance only and can be modified without prior advice

Type

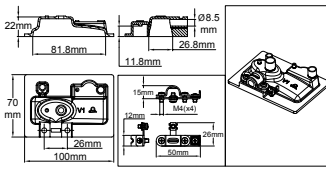
**9BFV**

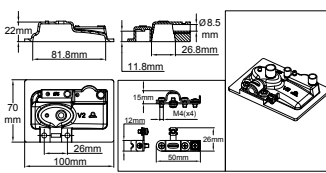
These enclosures include a stainless-steel removable locking device for the power cable and an internal and external grounding terminal. The flexibility of the silicone makes it possible to use cables with a diameter slightly greater (up to 15%) than that of the passage opening. They also comprise a degassing orifice and a «funnel» orifice for filling the silicone resin, which are cut after curing.

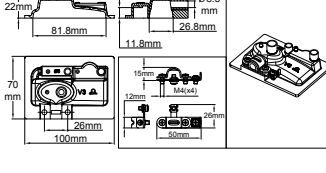
Type	Dimensions	Compatible devices	Features	Part number
		Naked welding thermocouples, glass bead NTC, flat chip Pt100. Disc thermostat type 4903 	<b>Minimum band width:</b> 100mm <b>Connection:</b> 5 conductor external cable <b>Silicone resin filling:</b> yes	9BFV1
		Dia. 5mm temperature sensors with 30mm maximum probe length	<b>Minimum band width:</b> 100mm <b>Connection:</b> 5 conductor external cable <b>Silicone resin filling:</b> yes	9BFV2
		Dia. 6mm temperature sensors with 30mm maximum probe length	<b>Minimum band width:</b> 100mm <b>Connection:</b> 5 conductor external cable <b>Silicone resin filling:</b> yes	9BFV3

**Indicative table of cable and wire diameters**

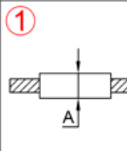
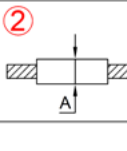
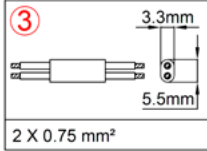
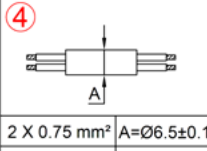
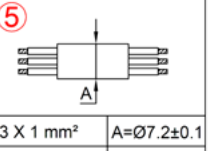
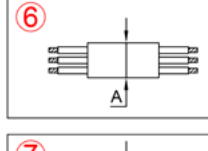
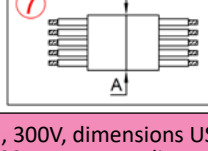
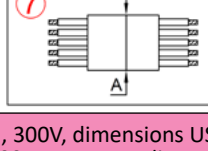
	AWG22 A=Ø1.4±0.1 AWG20 A=Ø1.6±0.1 AWG18 A=Ø1.9±0.1 AWG16 A=Ø2.2±0.1 AWG15 A=Ø2.3±0.1		0.5 mm <sup>2</sup> A=Ø1.5±0.1 0.75 mm <sup>2</sup> A=Ø1.8±0.1 1 mm <sup>2</sup> A=Ø1.9±0.1 1.5 mm <sup>2</sup> A=Ø2.2±0.1		3.3mm 5.5mm 2 X 0.75 mm <sup>2</sup>
	2 X 0.75 mm <sup>2</sup> A=Ø6.5±0.1 2 X 1 mm <sup>2</sup> A=Ø6.8±0.1		3 X 1 mm <sup>2</sup> A=Ø7.2±0.1 3 X 1.5 mm <sup>2</sup> A=Ø8.4±0.1		3 X 1.5 mm <sup>2</sup> A=Ø9.1±0.2 3 X 1 mm <sup>2</sup> A=Ø7.4±0.2 3 X AWG18 A=Ø7.8±0.2 3 X AWG16 A=Ø8.4±0.2
					5 X 1.5 mm <sup>2</sup> A=Ø11.1±0.2 5 X 1 mm <sup>2</sup> A=Ø9.0±0.2 5 X AWG18 A=Ø9.3±0.2 5 X AWG16 A=Ø10.1±0.2

1: Round wires FEP insulation, 300V, dimensions USA;  
 2: Round wires FEP insulation, 300V, European dimensions;  
 3: Flat cable PVC insulation, 300V, European dimensions;  
 4: Round cables 2 conductors PVC insulation, 300V, European dimensions;  
 5: Round cables 3 conductors PVC insulation, 300V, European dimensions;  
 6: Round cables 3 conductors rubber insulation 300V, European and USA dimensions.  
 7: Round cables 5 conductors rubber insulation 300V, European and USA dimensions.

# Pockets, flanges, brackets and other accessories



## Liquid temperature sensing with rod thermostats

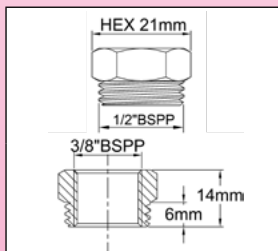
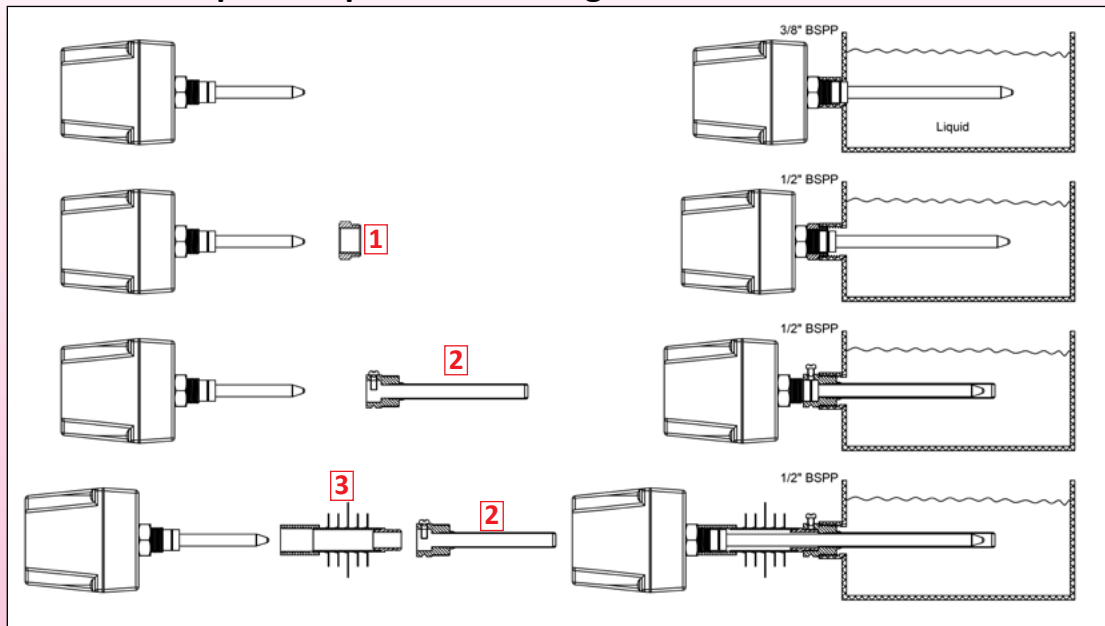

**1**

$\frac{3}{8}'' \times \frac{1}{2}''$ , 304 stainless steel fitting (fits the  $\frac{3}{8}''$  thread located under the housing)

Reference	66RI1238
-----------	----------

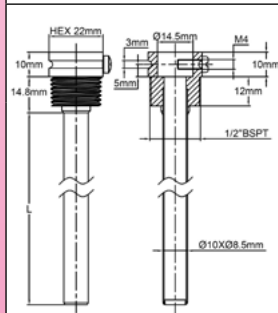

**2**

G $\frac{1}{2}$  (BSPT) Nickel plated brass pocket dia. 8.5 x 10mm, for rods dia. 8mm

L	References
90mm	66DK12S090710
100mm	66DK12S100710
190mm	66DK12S190710
230mm	66DK12S230710
290mm	66DK12S290710
440mm	66DK12S440710

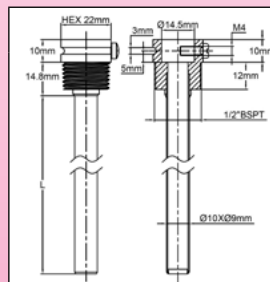

**2**

G $\frac{1}{2}$  (BSPT) Aisi 304 Stainless steel pocket dia. 9 x 10mm, for rods dia 8mm

L	References
90mm	66DI12S090S10
100mm	66DI12S100S10
190mm	66DI12S190S10
230mm	66DI12S230S10
290mm	66DI12S290S10
440mm	66DI12S440S10

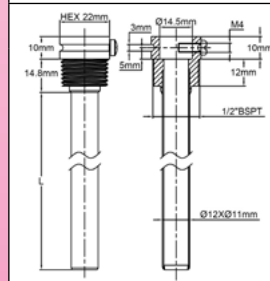

**2**

G $\frac{1}{2}$  (BSPT) Aisi 304 Stainless steel pocket dia. 11 x 12mm, for rods dia. 10mm

L	References
90mm	66DI12S090S12
100mm	66DI12S100S12
190mm	66DI12S190S12
230mm	66DI12S230S12
290mm	66DI12S290S12
440mm	66DI12S440S12

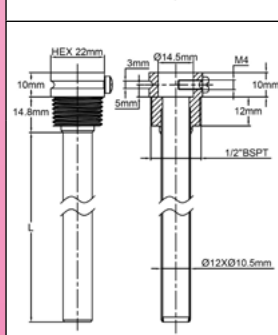

**2**

G $\frac{1}{2}$  (BSPT) Nickel plated brass pocket dia 10.5 x 12mm, for rods dia. 10mm

L	References
90mm	66DK12S900712
110mm	66DK12S100712
200mm	66DK12S190712
230mm	66DK12S230712
300mm	66DK12S290712
440mm	66DK12S440712

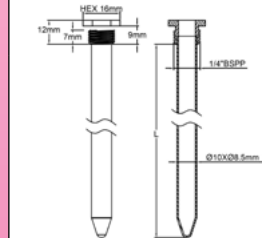

**2**

G $\frac{1}{4}$  (BSPT) Nickel plated brass pocket dia. 8.5 x 10mm, for rods dia. 8mm

L	References
100mm	66DL14P10010075N
190mm	66DL14P19010075N
290mm	66DL14P29010075N
440mm	66DL14P44010075N

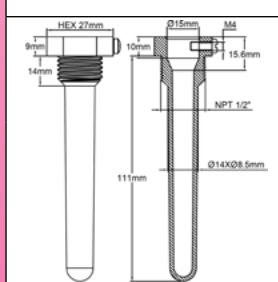

**2**

$\frac{1}{2}$  NPT plastic pocket dia. 8.5 x 14mm for rods and bulbs dia 8mm (Swimming pools and corrosive water applications)

Reference	66DR12S10021C000
-----------	------------------

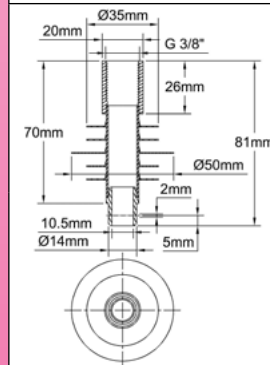

**3**

Rod cooler with 14.5mm termination. Used on high temperature rod thermostats. Fits the  $\frac{3}{8}''$  thread located under the housing and the dia. 14.5mm hole of pockets or flanges  
Not usable on YO types

Reference	66RF07015
-----------	-----------

Because of permanent improvement of our products, drawings, descriptions, features used on these data sheets are for guidance only and can be modified without prior advice



# Pockets, flanges, brackets and other accessories

## Liquid temperature sensing with bulb and capillary thermostats

Because of permanent improvement of our products, drawings, descriptions, features used on these data sheets are for guidance only and can be modified without prior advice

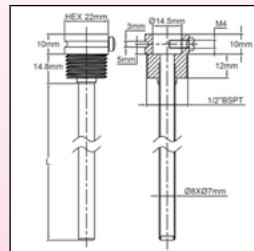
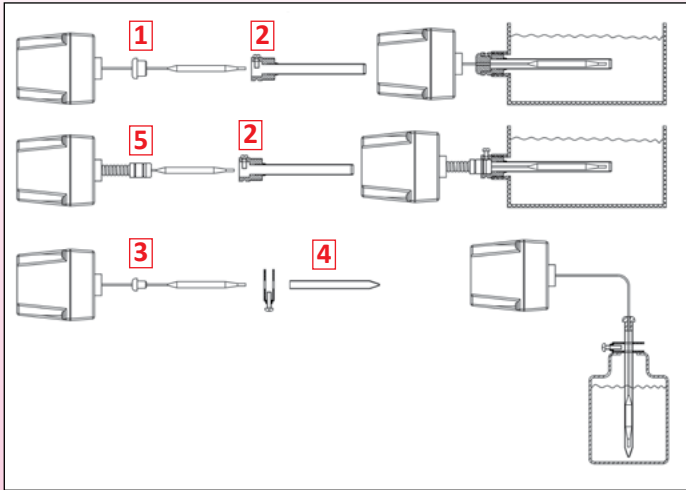

**2**

G½ (BSPT) Stainless steel pocket dia. 7 × 8mm, for bulbs dia. 5 and 6mm

L	Reference
100mm	66DI12S100S08
190mm	66DI12S190S08
290mm	66DI12S290S08
440mm	66DI12S440S08

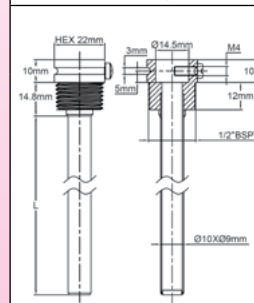

**2**

G½ (BSPT) Stainless steel pocket dia. 9 × 10mm, for bulbs dia. 8mm

L	Reference
100mm	66DI12S100S10
190mm	66DI12S190S10
290mm	66DI12S290S10
440mm	66DI12S440S10

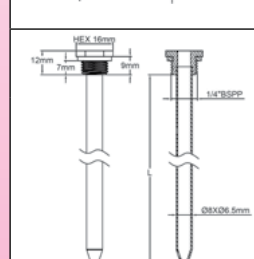

**2**

G¼ (BSPP) Nickel plated brass pocket dia. 6.5 × 8mm, for bulbs dia. 6mm

L	References
100mm	66DL14P10010065N
190mm	66DL14P19010065N
290mm	66DL14P29010065N
440mm	66DL14P44010065N

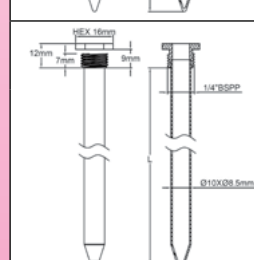

**2**

G¼ (BSPP) Nickel plated brass pocket dia. 8.5 × 10mm, for bulbs dia. 8mm

L	References
100mm	66DL14P10010075N
190mm	66DL14P19010075N
290mm	66DL14P29010075N
440mm	66DL14P44010075N

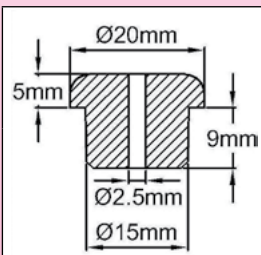

**1**

Silicone grommet dia. 15mm for pockets with 14.5mm hole

Reference	9BBJO100004008A
-----------	-----------------

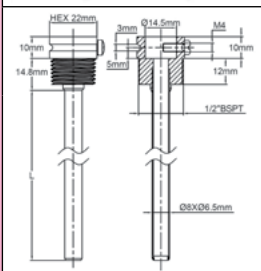

**2**

G½ (BSPT) Nickel plated brass pocket dia. 6.5 × 8mm, for bulbs dia. 5 and 6mm

L	References
100mm	66DK12S100708
190mm	66DK12S190708
290mm	66DK12S290708
440mm	66DK12S440708

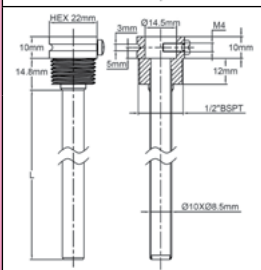

**2**

G½ (BSPT) Nickel plated brass pocket dia. 8.5 × 10mm, for bulbs dia. 8mm

L	References
100mm	66DK12S100710
190mm	66DK12S190710
290mm	66DK12S290710
440mm	66DK12S440710

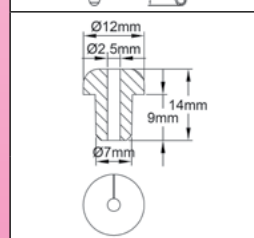

**3**

Silicone grommet dia. 7.5mm for tubes dia. 7 × 8mm

Reference	9BBJO10000452A
-----------	----------------

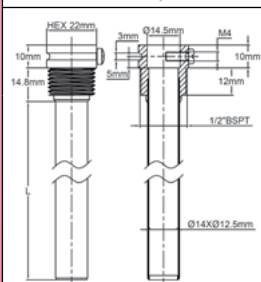

**2**

G½ (BSPT) Nickel plated brass pocket dia. 12.5 × 14mm, for 2 bulbs dia. 6mm side by side

L	References
100mm	66DK12S100714
190mm	66DK12S190714
290mm	66DK12S290714
440mm	66DK12S440714

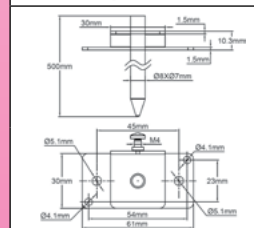

**4**

Aisi 304, adjustable length mobile pocket for tanks, buckets, containers, pipe dia 7 × 8mm, for bulbs dia. 6mm

Reference	66DA0008050400
-----------	----------------

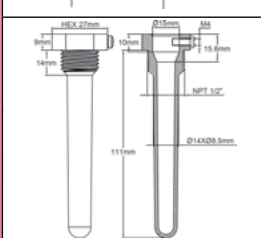

**2**

½ NPT plastic pocket dia. 8.5 × 14mm, for bulbs dia. 8mm

Reference	66DR12S10021C000
-----------	------------------

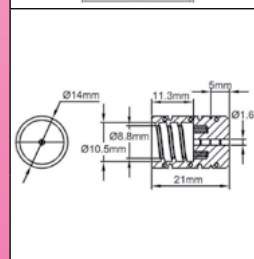

**5**

Dia. 10mm flexible corrugated tube output, plastic

Reference	9BBS10RA100003A
-----------	-----------------



## Air duct temperature sensing with rod thermostats

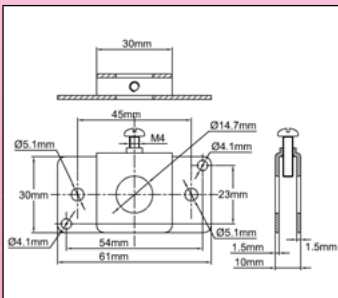
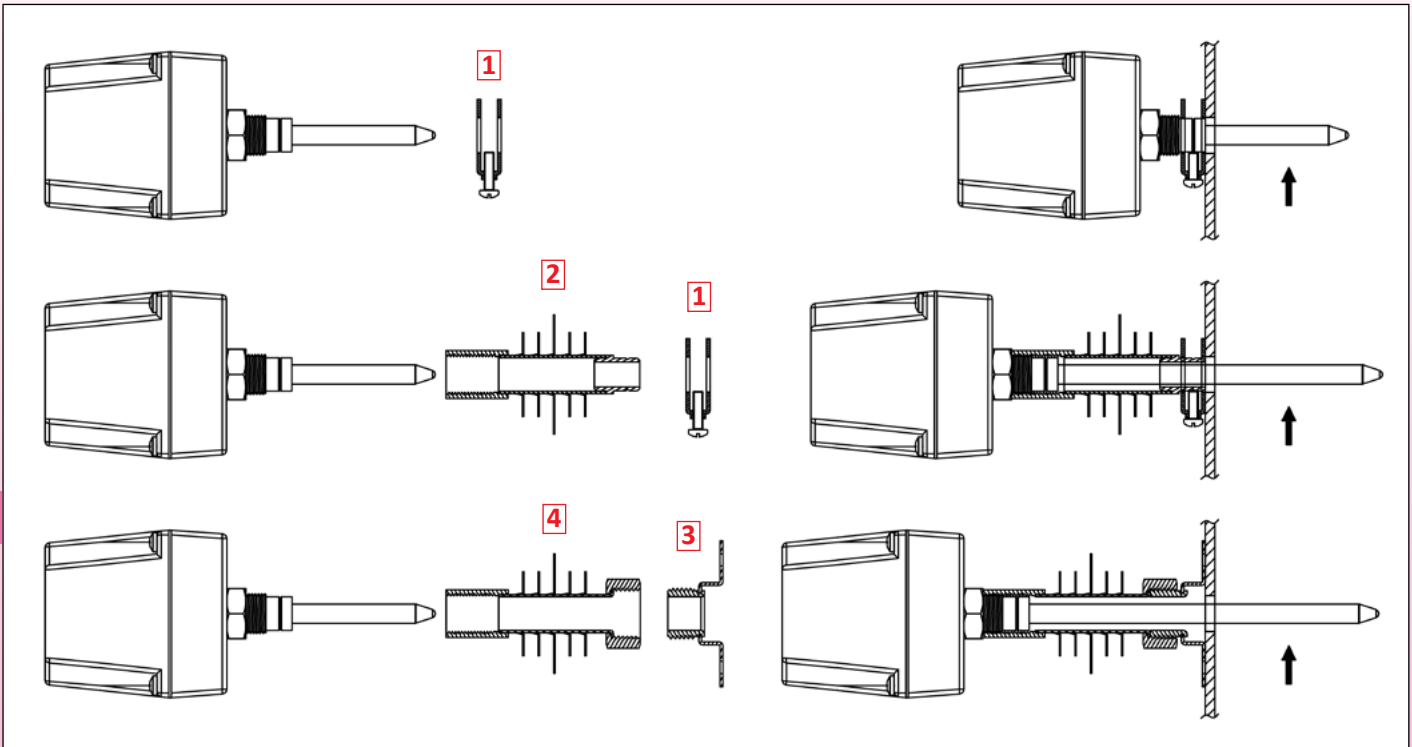

**1**



Stainless steel flange for dia. 14.5mm rod output

Reference	66BF1
-----------	-------

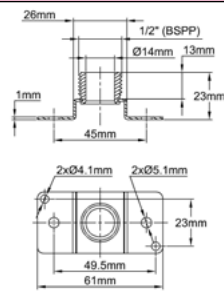

**3**



G $\frac{1}{2}$  Rod cooler bracket (for air ducts mounting)  
Not usable on Y0 types

Reference	66DA0008050400
-----------	----------------

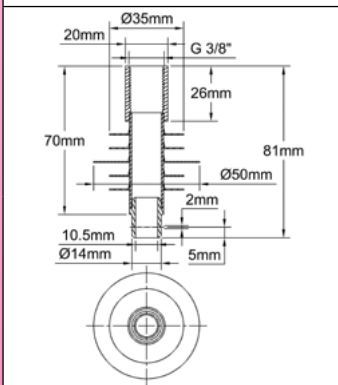

**2**



Rod cooler with 14.5mm termination.  
Used on high temperature rod thermostats.  
Fits the  $\frac{3}{8}$  thread located under the pockets or flanges  
Not usable on Y0 types

Reference	66RF07015
-----------	-----------

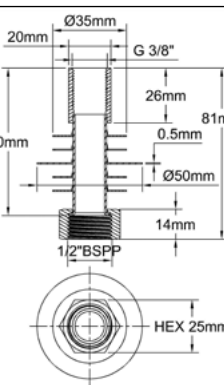

**4**



Rod cooler G $\frac{1}{2}$   
Used on high temperature rod thermostats. Fits the  $\frac{3}{8}$  thread located under the housing and the  $\frac{1}{2}$  male thread of rod cooler bracket  
Not usable on Y0 types

Reference	66RF0231M12
-----------	-------------





# Pockets, flanges, brackets and other accessories

## Air duct temperature sensing with bulb and capillary thermostats

Because of permanent improvement of our products, drawings, descriptions, features used on these data sheets are for guidance only and can be modified without prior advice

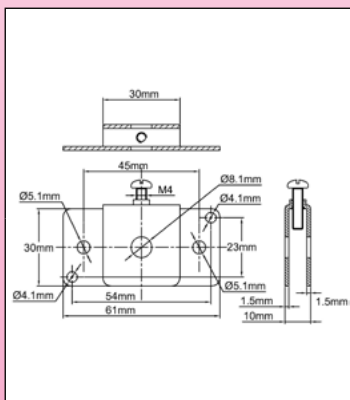
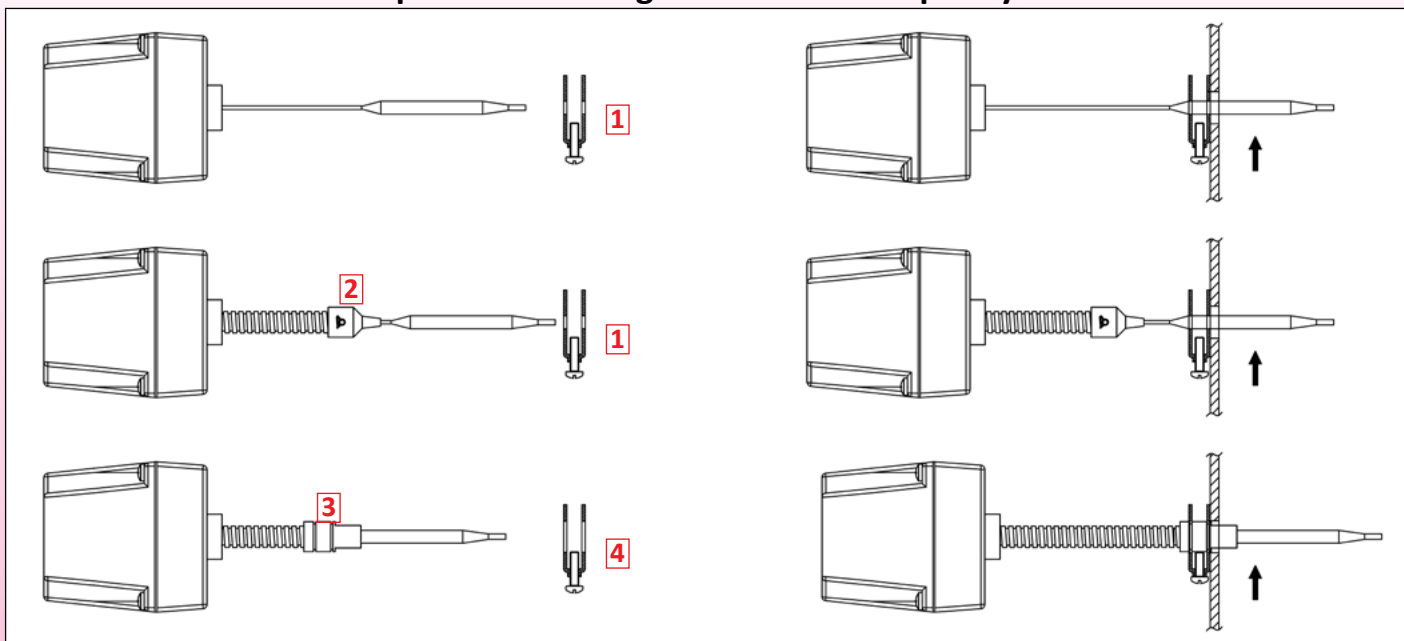

**1**



Stainless steel flange for dia. 8mm bulbs

Reference	66BF4
-----------	-------

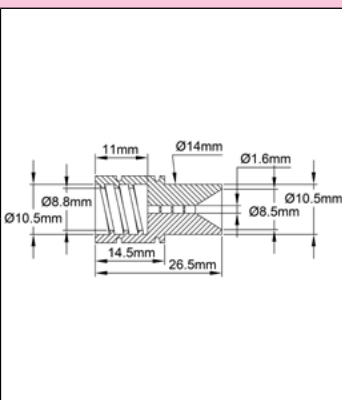

**3**



Dia. 10mm flexible corrugated tube output, through wall air duct mounting (plastic)

Reference	9BBSI10RA100005A
-----------	------------------

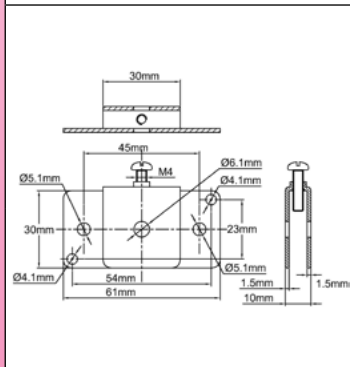

**1**



Stainless steel flange for dia. 6mm bulbs

Reference	66BF3
-----------	-------

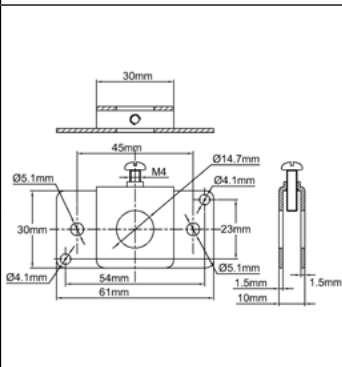

**4**



Stainless steel flange for dia 14.5mm capillary protection output

Reference	66BF1
-----------	-------

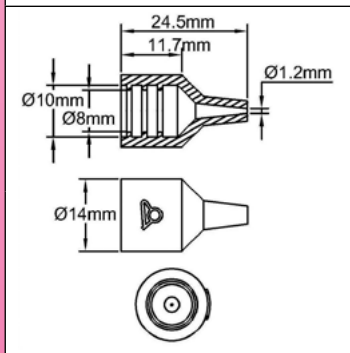

**2**



Dia. 10mm flexible corrugated tube  
Silicone output, 1 capillary

Reference	9BBJO1000000154A
-----------	------------------



## Pipe temperature measurement

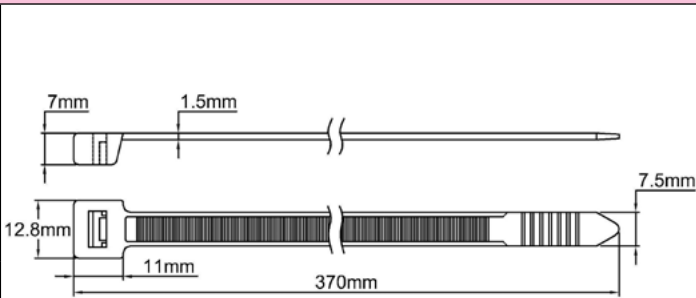
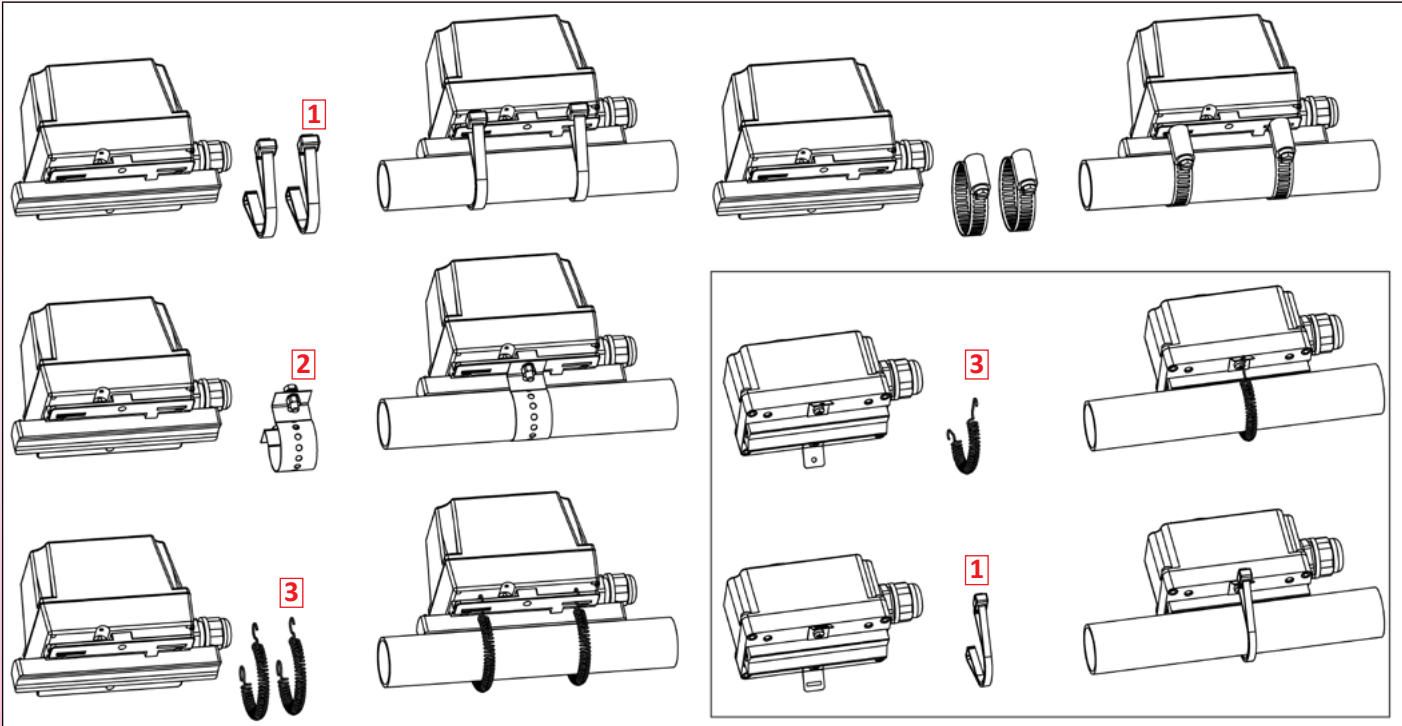

**1**

PA66 Cable tie for pipe mounting thermostats (for Y1 types). Max 80°C

Reference	66TY002
-----------	---------

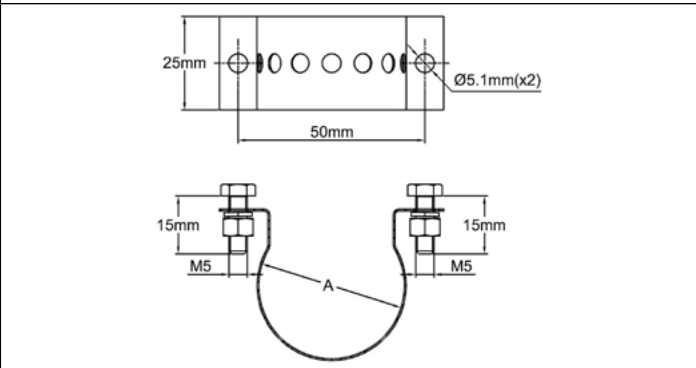

**2**

Stainless steel band for pipe mounting thermostats (for Y1 types)

Reference	66TY001
-----------	---------

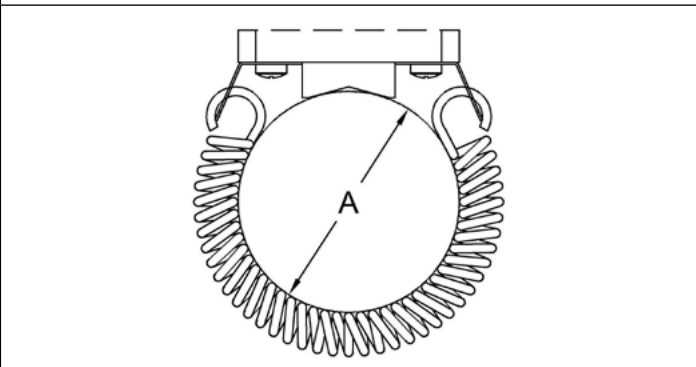

**3**

Spring for pipe mounting thermostat (for Y1 and Y2 types)

Reference	66TY003
-----------	---------

Because of permanent improvement of our products, drawings, descriptions, features used on these data sheets are for guidance only and can be modified without prior advice





# Pockets, flanges, brackets and other accessories

## Bulb and Capillary surface mounting accessories

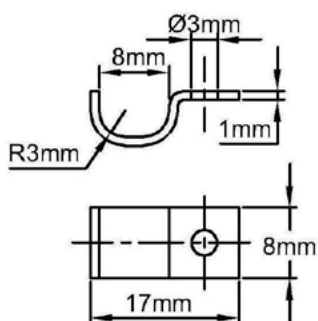
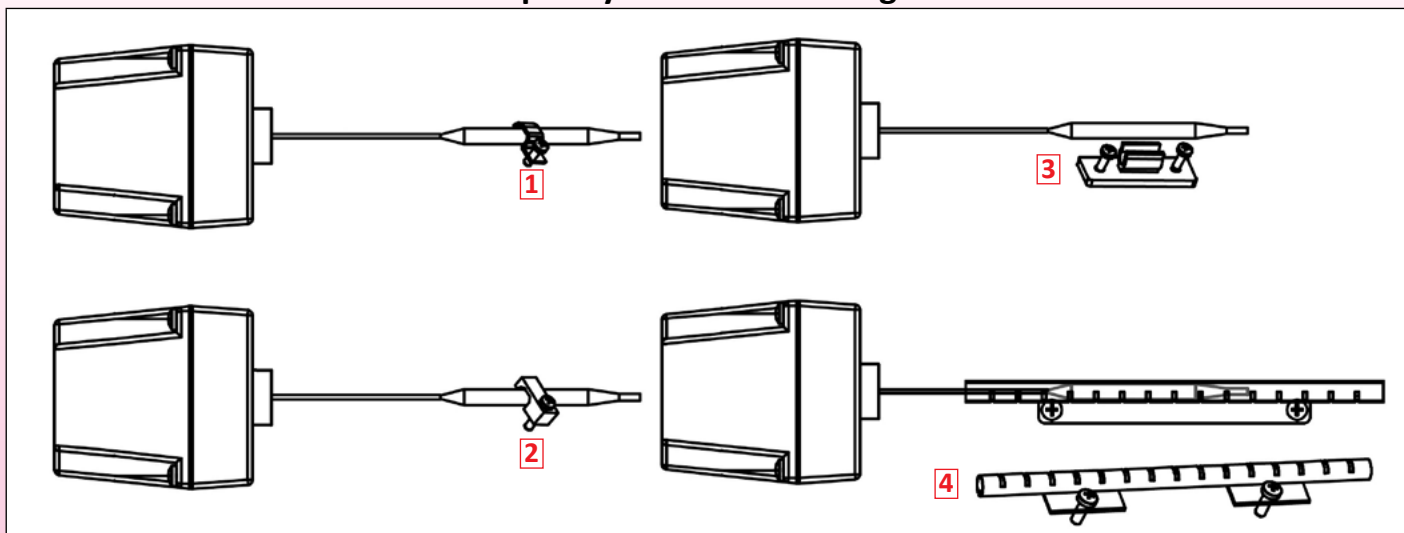

**1**

Bulb mounting clips  
Stamped steel, for bulbs dia. 5 and 6mm

Reference 66PA04500020

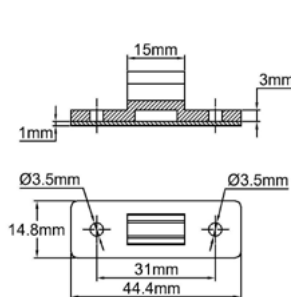

**3**

Bulb mounting clips  
PA66 Plastic, 2 screw mounting or adhesive, for bulbs dia. 5 and 6mm, maximum temperature 80°C

Reference 9BBFPM134211900

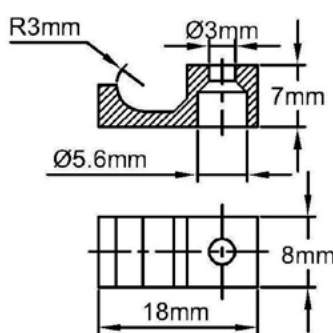

**2**

Bulb mounting clips  
Reinforced PC-ABS, screw mounting, for bulbs dia. 5 and 6mm, maximum temperature 90°C

Reference 9BBAE10000AFS07A

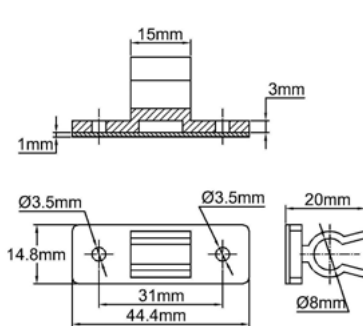

**3**

Bulb mounting clips, PA66 Plastic, 2 screw mounting or adhesive, for bulbs dia. 8mm., maximum temperature 80°C

Reference 9BBFPM124211900

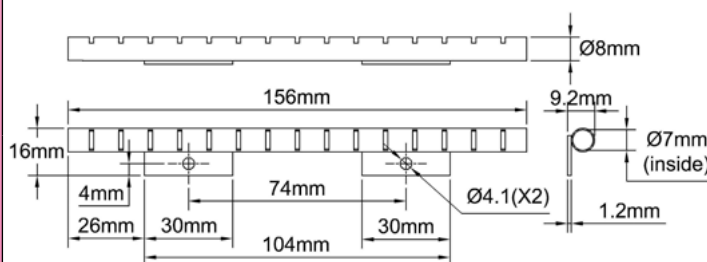

**4**

Bulb protective mounting bracket, stainless steel, 2 screw mounting, for bulbs dia. 5 and 6mm.

Reference 66DU

Because of permanent improvement of our products, drawings, descriptions, features used on these data sheets are for guidance only and can be modified without prior advice

# Pockets, flanges, brackets and other accessories



## Capillary protection for bulb and capillary thermostats and temperature sensor cables

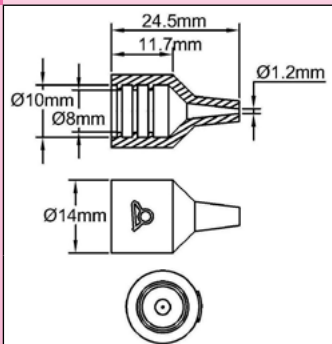
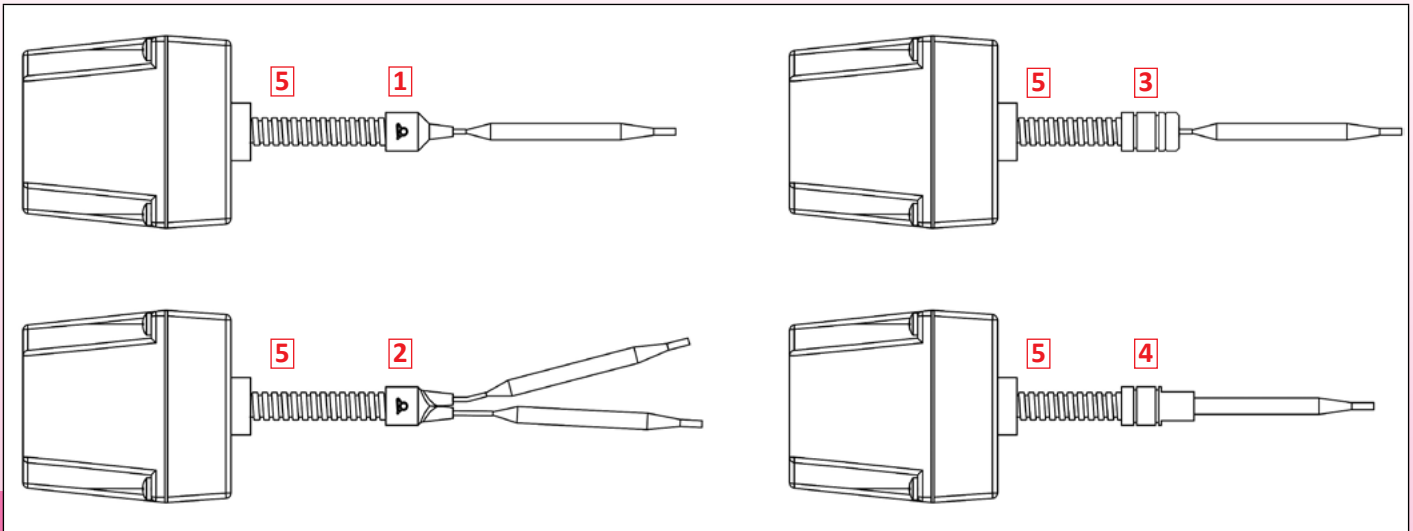

**1**

Dia. 10mm flexible corrugated tube  
Silicone output, 1 capillary

Reference	9BBJO1000000154A
-----------	------------------

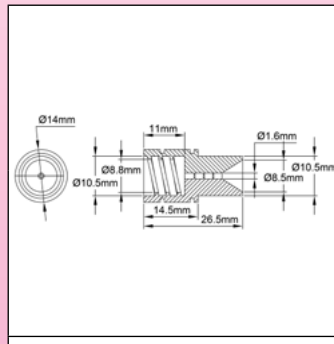

**4**

Dia. 10mm flexible corrugated tube  
output, through wall air duct  
mounting plastic

Reference	9BBSI10RA100005A
-----------	------------------

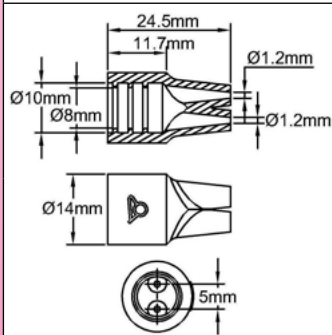

**2**

Dia. 10mm flexible corrugated tube  
Silicone output, 2 capillaries

Reference	9BBJO1000000177A
-----------	------------------

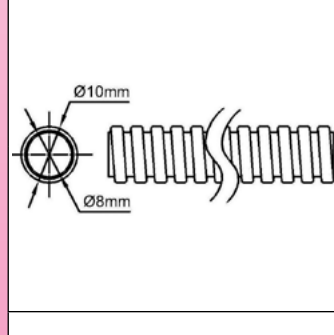

**5**

Dia. 10mm corrugated flexible tube,  
stainless steel

Reference	6YGSS10200 (20m reel)
-----------	--------------------------

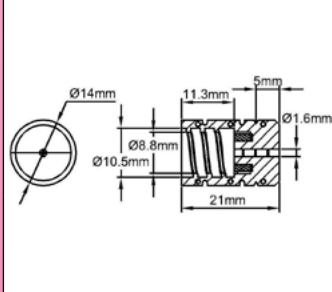

**3**

Dia. 10mm flexible corrugated tube  
output, plastic

Reference	9BBSI10RA100003A
-----------	------------------

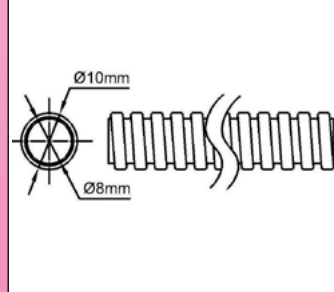

**5**

Dia. 10mm corrugated flexible tube,  
PA6, black, max temperature 125°C

Reference	6YGPU10200 (20m reel)
-----------	--------------------------

Because of permanent improvement of our products, drawings, descriptions, features used on these data sheets are for guidance only and can be modified without prior advice



## Electrical accessories

	<p>2.5mm<sup>2</sup>, 400V, 3 way connection block (fits Y0, Y1, Y2)</p> <p>Reference: BE3E3</p>		<p>M4 ground terminal with M4 saddle. Fits Y1 and Y2 series.</p> <p>Reference: 6YEBMG004</p>
	<p>M16 Cable gland, IP68, Black PA66, cables dia 5 to 10mm (with nut and gasket). Maximum temperature 85°C. Fits Y0 and Y1 series</p> <p>Reference: 6YTPEM16C05140</p>		<p>M20 cable gland, IP68, Black PA66, cables dia. 8 to 12mm (with nut and gasket) Maximum temperature 85°C. Fits Y2 type</p> <p>Reference: 6YTPEM20C0812</p>

## Spare parts

		<p>Nickel plated brass M20 screw cap with gasket, fits Y1 with external access under screwed cap</p> <p>Reference: 6YTPEM20PB</p>		<p>Stainless steel M4 screw cap with gasket, fits Y1 with external manual reset access</p> <p>Reference: 6YTPEM04SS</p>
--	--	---	--	---

Because of permanent improvement of our products, drawings, descriptions, features used on these data sheets are for guidance only and can be modified without prior advice



Because of permanent improvement of our products, drawings, descriptions, features used on these data sheets are for guidance only and can be modified without prior advice







# ULTIMHEAT

---

## HEAT & CONTROLS



Catalogues collection on  
[www.ultimheat.com](http://www.ultimheat.com)

**Electromechanical components & OEM heating sub-assemblies manufacturer**

- Mechanical thermostats
- Mechanical safeties single & three poles
- ATEX thermostats & safeties
- Flow through liquid heaters
- Immersion heaters
- Heating elements for air and liquid
- Connection blocks
- Housings for corrosive environments
- Flow switches
- Level switches
- Pressure switches and air switches
- Fusible links and fire detection mechanisms
- Tracing equipment
- **Taylor made solutions**



# THEIR MOST PROUD MESSAGES

THEIR MOST PROUD MESSAGES

THEIR MOST PROUD MESSAGES